



City of Opportunity. Moving Forward!

**CITY OF AUSTELL
DESIGN AND CONSTRUCTION STANDARDS
STANDARD DETAILS**



City of Opportunity. Moving Forward!

DETAIL A4 SPECIAL DETAIL: DETECTABLE WARNING SURFACE TRUNCATED DOME SIZE, SPACING, AND ALIGNMENT REQUIREMENTS

SIZE: DETECTABLE WARNINGS SHALL BE 24 INCHES (610 mm) IN THE DIRECTION OF PEDESTRIAN TRAVEL AND EXTEND THE FULL WIDTH OF THE CURB RAMP OR FLUSH SURFACE.
LOCATION: THE DETECTABLE WARNING SHALL BE LOCATED SO THAT THE EDGE NEAREST THE CURB LINE OR OTHER POTENTIAL HAZARD IS 6 TO 8 INCHES (150 mm TO 180mm) FROM THE CURB LINE OR OTHER POTENTIAL HAZARD, SUCH AS A REFLECTIVE POOL EDGE OR THE DYNAMIC ENVELOPE OF RAIL OPERATIONS.

DOMES SIZE AND SPACING: TRUNCATED DOMES SHALL HAVE A BASE DIAMETER OF 0.9 INCH (23mm-36mm) AT THE BOTTOM, A DIAMETER OF 0.45 INCH (11mm-23mm) AT THE TOP, THE TOP DIAMETER SHALL BE A MINIMUM OF 50% AND A MAXIMUM OF 65% OF THE BASE DIAMETER. A HEIGHT OF 0.2 INCH (5.1mm) AND A CENTER-TO-CENTER SPACING OF 2.40 INCHES (61mm) DESIRABLE 1.60 INCHES (41mm) MINIMUM MEASURED ALONG ONE SIDE OF A SQUARE ARRANGEMENT. DOMES SHALL HAVE A SQUARE ARRANGEMENT. DOMES SHALL BE ALIGNED ON A SQUARE GRID IN THE PREDOMINANT DIRECTION OF TRAVEL TO PERMIT WHEELS TO ROLL BETWEEN DOMES.

VISUAL CONTRAST: DETECTABLE WARNING SURFACES SHALL CONTRAST VISUALLY WITH THE ADJACENT WALKING SURFACE EITHER LIGHT-ON-DARK OR DARK-ON-LIGHT. THE MATERIAL USED TO PROVIDE VISUAL CONTRAST SHALL BE AN INTEGRAL PART OF THE DETECTABLE WARNING SURFACE.

MATERIALS:
NEW CONSTRUCTION
THE DETECTABLE WARNINGS SHALL BE MADE OF MATERIALS SPECIFIED ON OPL 87.

RETROFIT OF EXISTING RAMPS
SURFACED APPLIED MATERIALS WILL ONLY BE APPROVED TO BE USED ON EXISTING WHEELCHAIR RAMPS.

INSTALLATION:
BRICK PAVERS SHALL BE SET IN A WET MORTAR BED. THE BED SHALL BE PLACED ON CONCRETE. THE CONCRETE SHALL BE A MINIMUM OF 4" THICK.

CERAMIC TILE SHALL BE EPOXYED IN PLACE OR SET IN A WET MORTAR BED. MANUFACTURER RECOMMEND ADHESIVE OR FASTENER SHALL BE USED IN THE INSTALLATION.

ALL OTHER MATERIALS SHALL BE INSTALLED ACCORDING TO MANUFACTURE DETAILS OR INSTRUCTION.

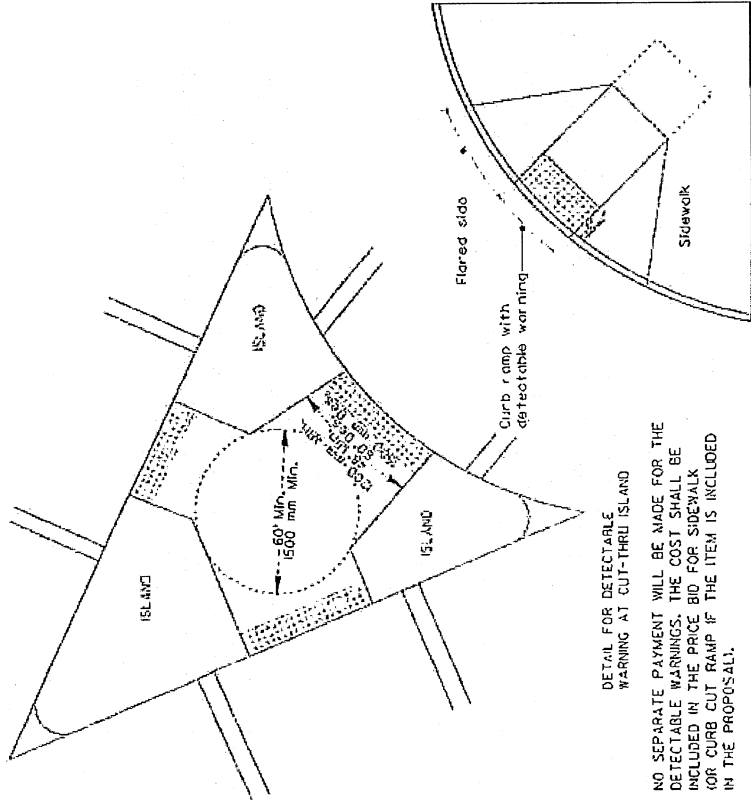
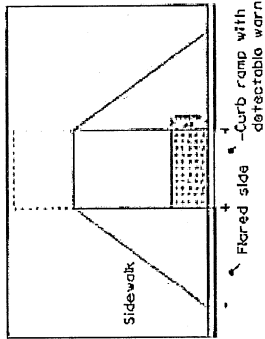

DETAIL FOR DETECTABLE WARNING AT CUT-THRU ISLAND

NO SEPARATE PAYMENT WILL BE MADE FOR THE DETECTABLE WARNINGS. THE COST SHALL BE INCLUDED IN THE PRICE BID FOR SIDEWALK OR CURB CUT RAMP IF THE ITEM IS INCLUDED IN THE PROPOSAL.

FOR CUT-THRU ISLANDS AND EXISTING RAMPS, WHERE NO SIDEWALK OR CURB CUT RAMPS ARE IN THE PROPOSAL, THE COST OF THE DETECTABLE WARNINGS SHALL BE INCLUDED IN THE OVERALL BID PRICE SUBMITTED.

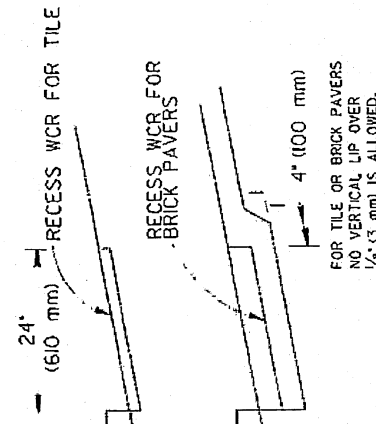
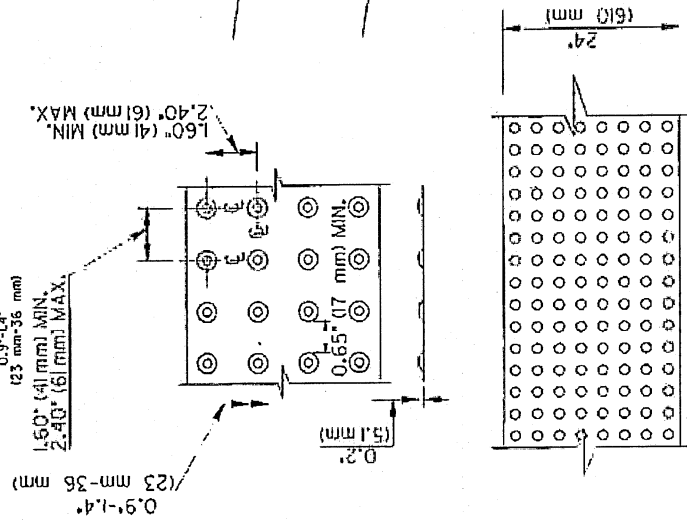

FOR TILE OR BRICK PAVERS NO VERTICAL LIP OVER 1/8\"/>



City of Opportunity. Moving Forward!

DETAIL 80 UTILITY STANDARD

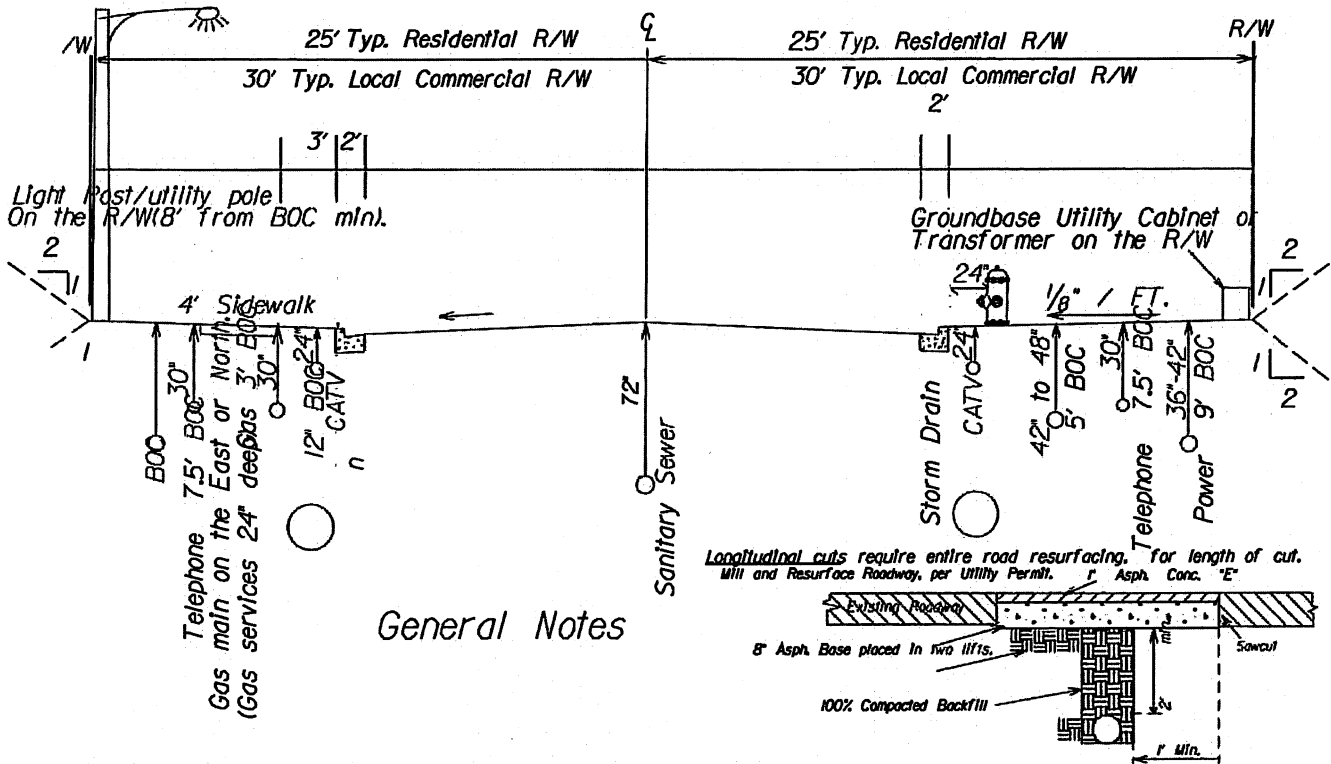

General Notes

- Roadway or driveway open-cut permit is required from Austell Public Works
- Landscaping, structures, or irrigation systems are NOT allowed in the right-of-way.
- Storm drain location and size shown as guide only. Design to dictate actual size and location. Utility adjustments to approved by site inspector.
- Sidewalks are to be placed on the North or East side of street.
- Waterline to be placed on the West or South side of street.
- Signal Notes: All signal plans must be submitted to and approved by Cobb County or the Georgia Department of Transportation. Approval must be submitted to Austell Public Works prior to Land Disturbance Permit approval. Any signal traffic work shall be performed in accordance with traffic signal specifications. Any traffic signal equipment damaged as of result of project shall be replaced/upgraded by the contractor/developer immediately. Damaged loops shall be replaced/upgraded with video detection. The contractor/developer is required to maintain video detection without interruption for all traffic signal phases affected during construction of the project. Approved video detection shall be used for presence detection and approved video or microwave detection shall be used for pulse detection. Additional poles/equipment may be required to support these detection devices.
- Street lighting to be designed by power company and approved by Austell Public Works.
- Construction equipment shall not be parked in areas which restrict sign distance to any drives or traffic.
- Street lane or total road closure permit: The contractor/developer is required to obtain one of these permits prior to beginning any work. Contact Austell Public Works at (770) 944-4325.
- Contractor/developer shall maintain driveway access and post service at all times.
- Any infrastructure (pavement, signals, drainage structures, curb, sidewalk, etc.) damaged or displaced as part of the project shall be replaced by the contractor/developer.
- Measurements shown above are from the back of curb to the center of the structure.
- Street trench/cut repair is required per detail.
- No drop-offs adjacent to roadway after work hours.
- 13' shoulder is required. All poles to be 8' from back of curb, minimum.
- Traffic control devices (signs, signals, markings) and certified flagman are required and shall meet MUTCD Standards, latest edition.



City of Opportunity. Moving Forward!

DETAIL 80A UTILITY STANDARD LOCAL URBAN STREET

40' RIGHT-OF-WAY

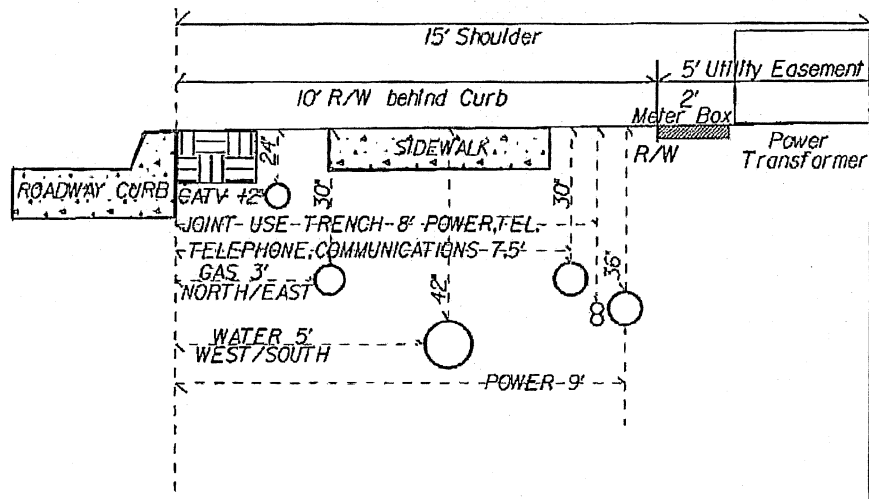

NOTE: Reduced right-of-way concept requires approval via the Zoning Process.
 Street lights are to be on the back of the utility easement.
 Utilities are to deflect around drainage structure as required or per site inspector.



City of Opportunity. Moving Forward!

DETAIL 80B UTILITY STANDARD PRIVATE URBAN ALLEY

30' ACCESS AND 10' UTILITY EASEMENT

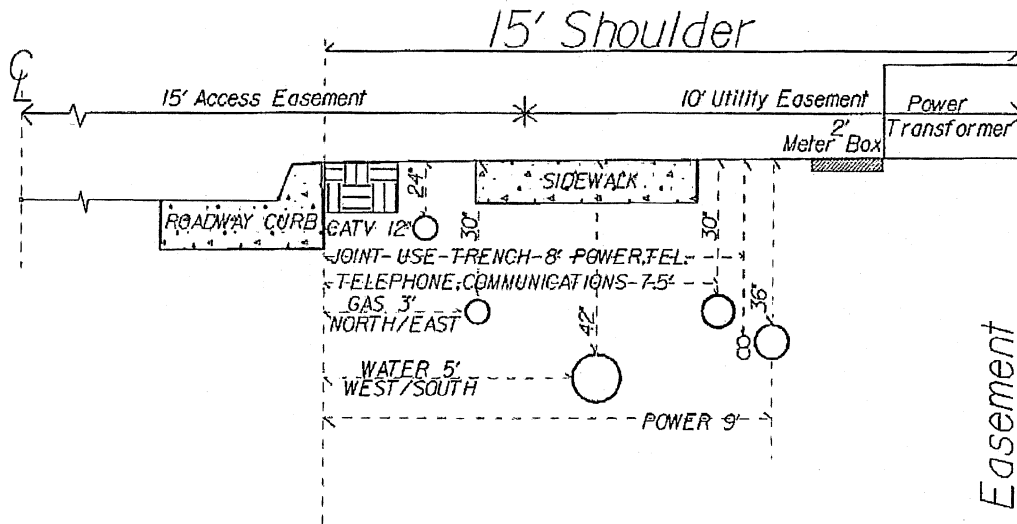



City of Opportunity. Moving Forward!

DETAIL 81A UTILITY LOCATIONS PLAN VIEW LOCAL URBAN STREETS

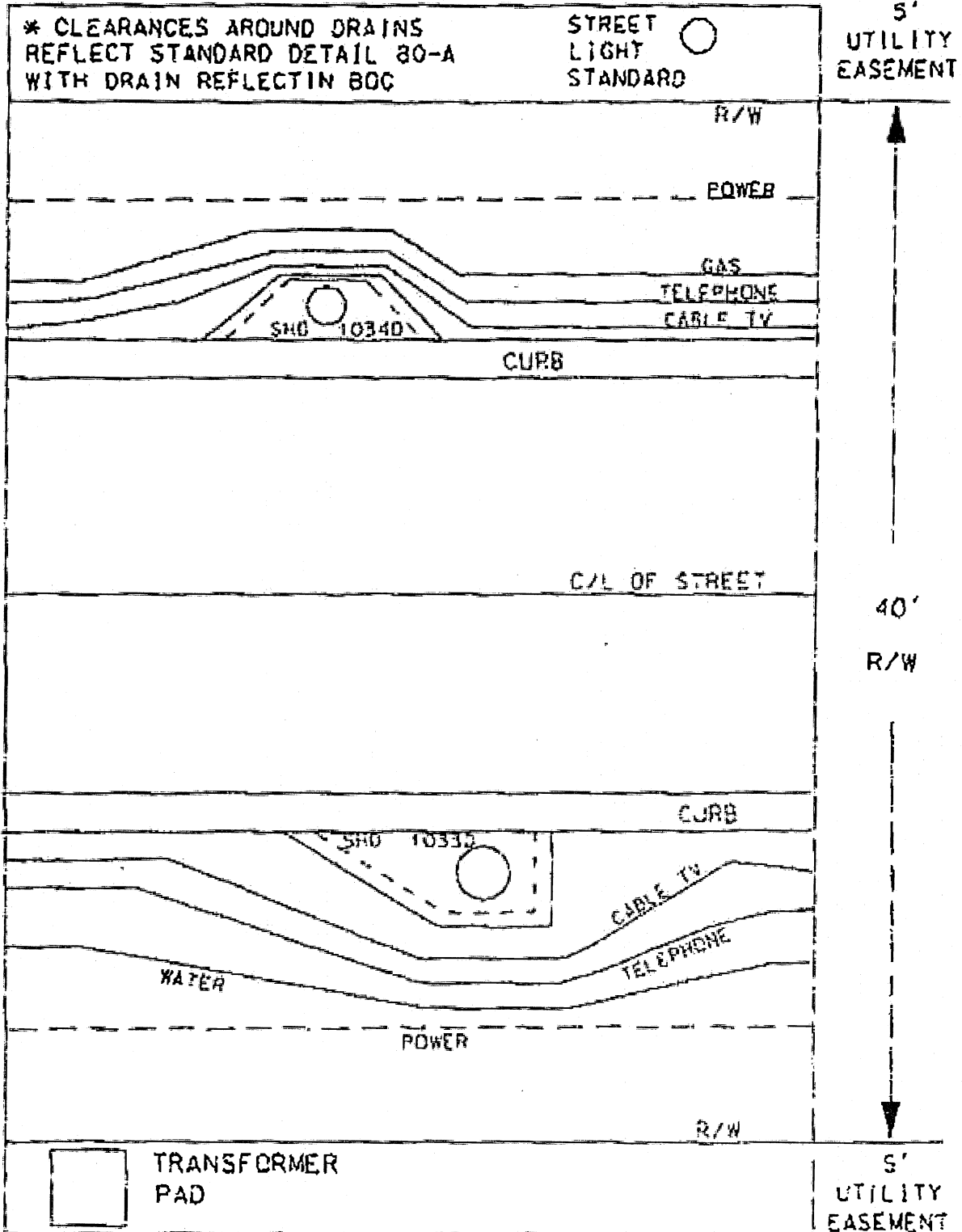



City of Opportunity. Moving Forward!

DETAIL 100A TYPICAL SECTION RESIDENTIAL STREET

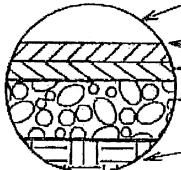
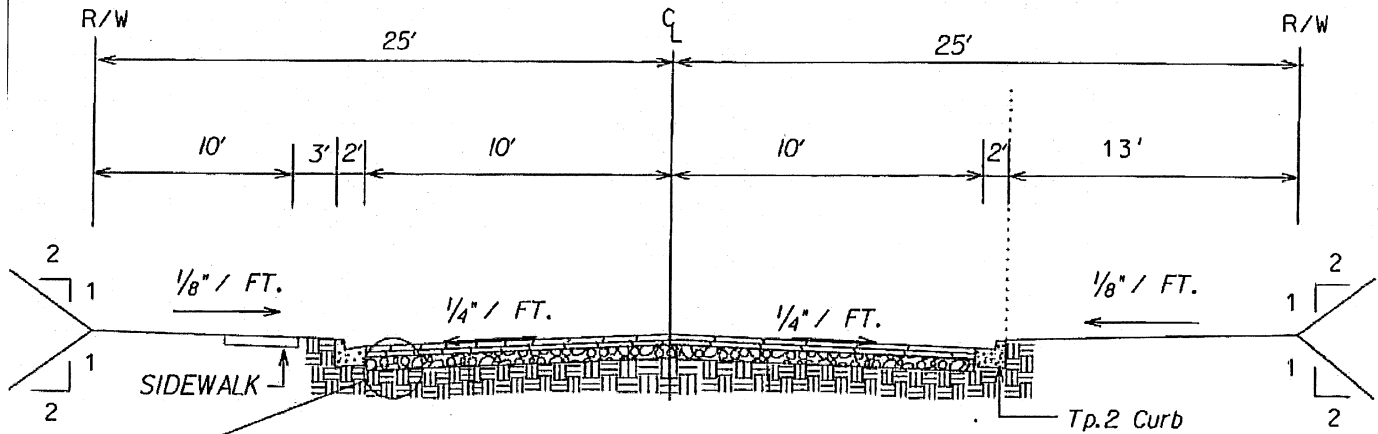

- 1.5" ASPH. "E" TOPPING (Including H.Lime)
- 1.5" ASPH. "B" BINDER (TACKED)(Including H.Lime)
- 8" GRADED AGGREGATE BASE (PRIMED) 100% COMPACTION, Std Proctor
- COMPACTED SUBGRADE, Std Proctor

All road construction, materials and methods are subject to testing and tolerances in accordance with GDOT Standard Specifications, latest Edition.



City of Opportunity. Moving Forward!

DETAIL 100B RESIDENTIAL STREET GRADING

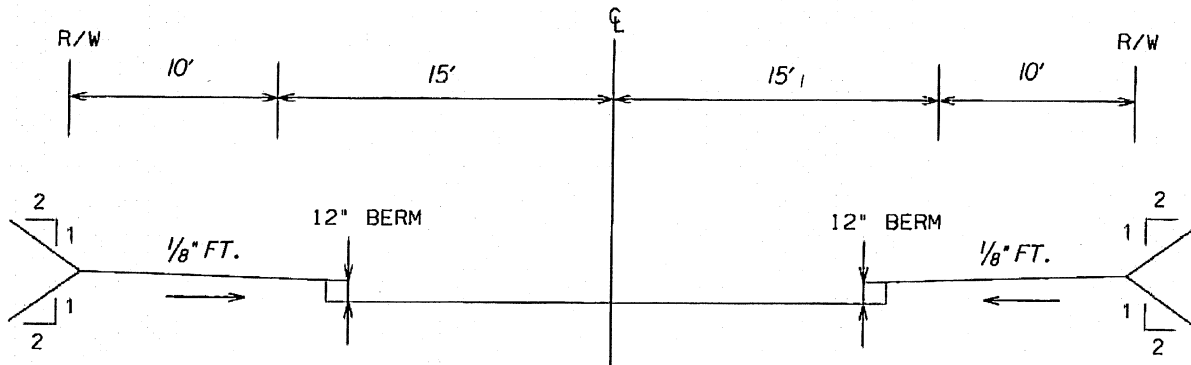

- NOTE: Asphalt mix must meet current Georgia Department of Transportation standards.
- 24" of paving is required for Residential Collector roads.
- All street front is to be L-back curbed.
- Road subgrade fill compaction to be 90% up to top 12", 100% for top 12" (standard proctor)
- Residential right-of-way signage to be placed by Austell Public Works.
- Aesthetic signs, at developers expense, may be approved through Austell Community Development, by permit only.
- NO permanent traffic control, signs, or striping to be placed without approval from Austell Public Works.
- Turnaround pad is required when access a Major Thoroughfare.



City of Opportunity. Moving Forward!

DETAIL 102 RURAL RESIDENTIAL STREET

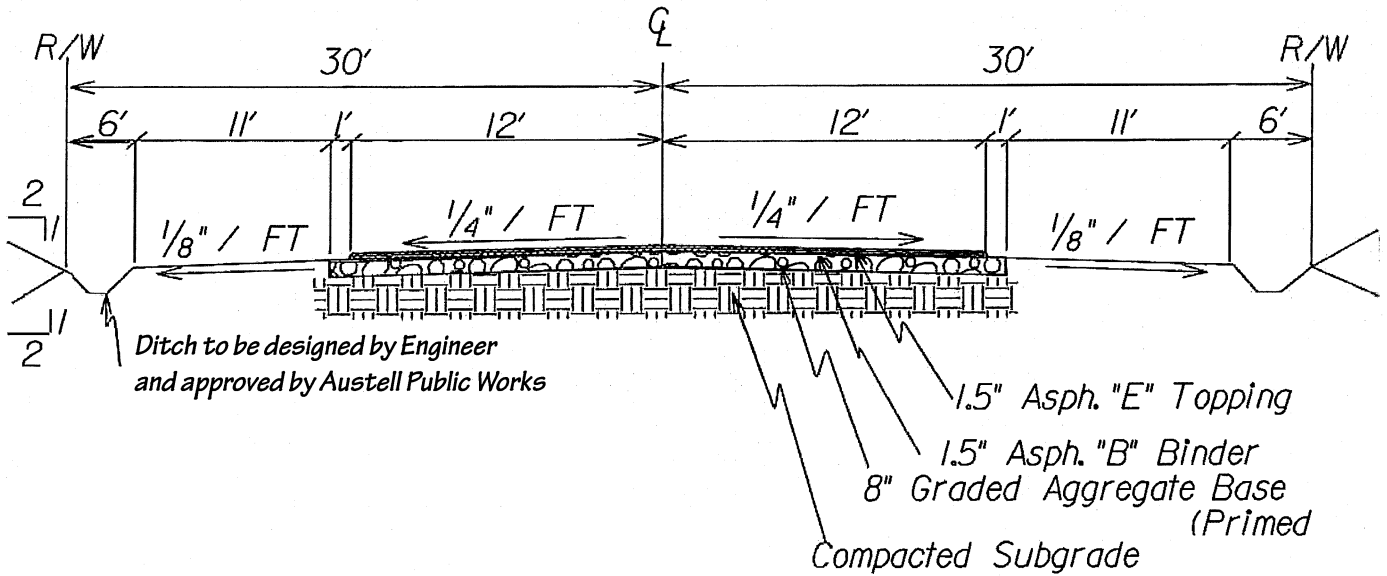

NOTE: For use with R80 or greater Residential zoning & subject to CDOT approval.
Road fill compaction to be 95% up to top 12" and 100% for top 12" (Std Proctor).

UNDERGROUND UTILITY LOCATION FOR RURAL RESIDENTIAL STREETS

<u>UTILITY</u>	<u>DISTANCE FROM CENTERLINE</u>	<u>DEPTH</u>
Electrical power	20 Feet	3 Feet
Water	17 Feet	4 Feet
Telephone	13.5 Feet	2 Feet
Gas	15 Feet	2.5 Feet
TV	18.5 Feet	2" Feet



City of Opportunity. Moving Forward!

DETAIL 103 INTERSECTION LANDING REQUIREMENTS

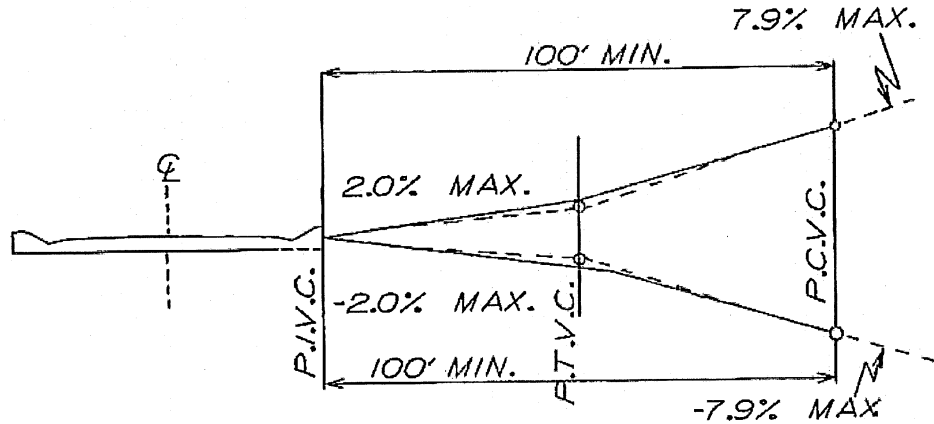

LANDING REQUIREMENTS
FOR GRADES 7.9% OR LESS

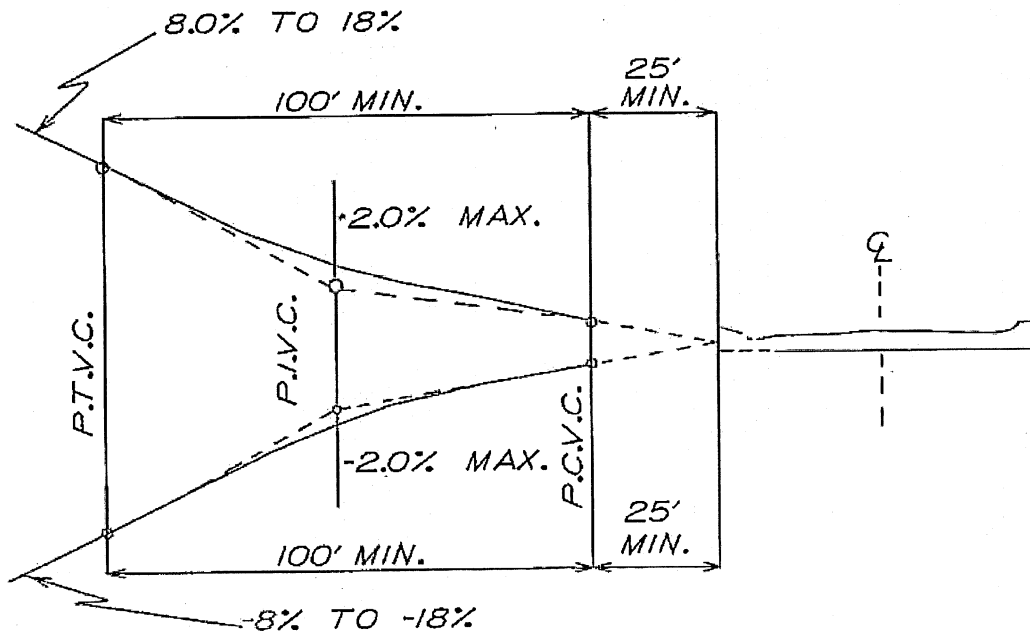

LANDING REQUIREMENTS
FOR GRADES 8.0% TO 18% MAX

NOTE: A 1% landing is allowable.
 All other grades are to be 1.5% Min.
 For street grades other than a local, refer to Development Standards Section 401.2.02.



City of Opportunity. Moving Forward!

DETAIL 104(A) TYPICAL RESIDENTIAL CUL-DE-SAC

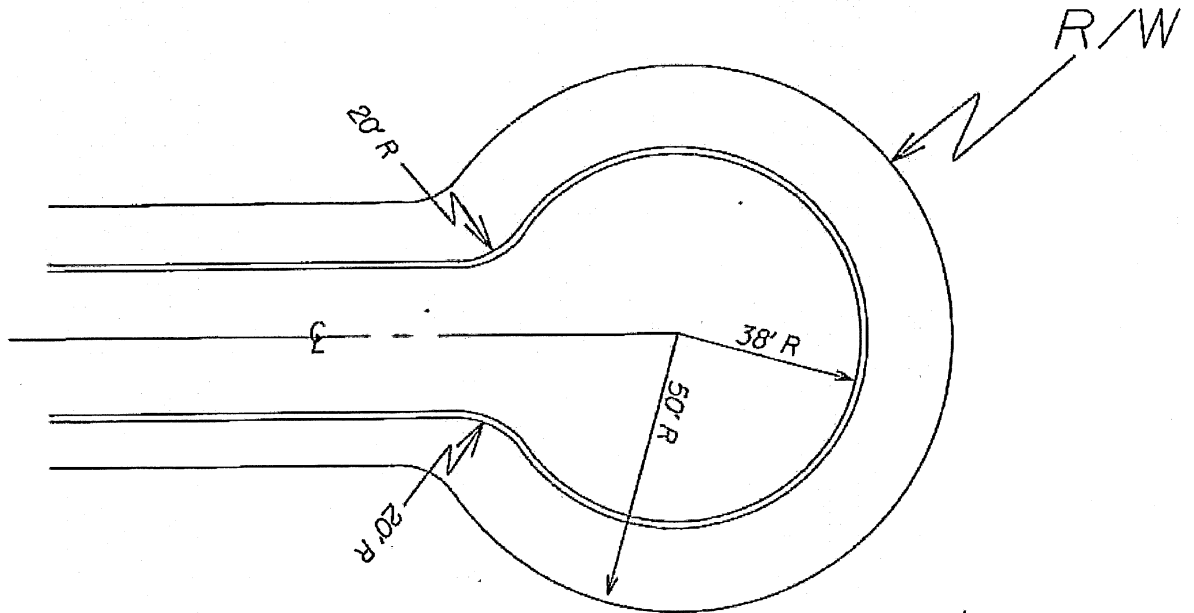



DETAIL 104(B) TYPICAL OFFSET CUL-DE-SAC

City of Opportunity. Moving Forward!

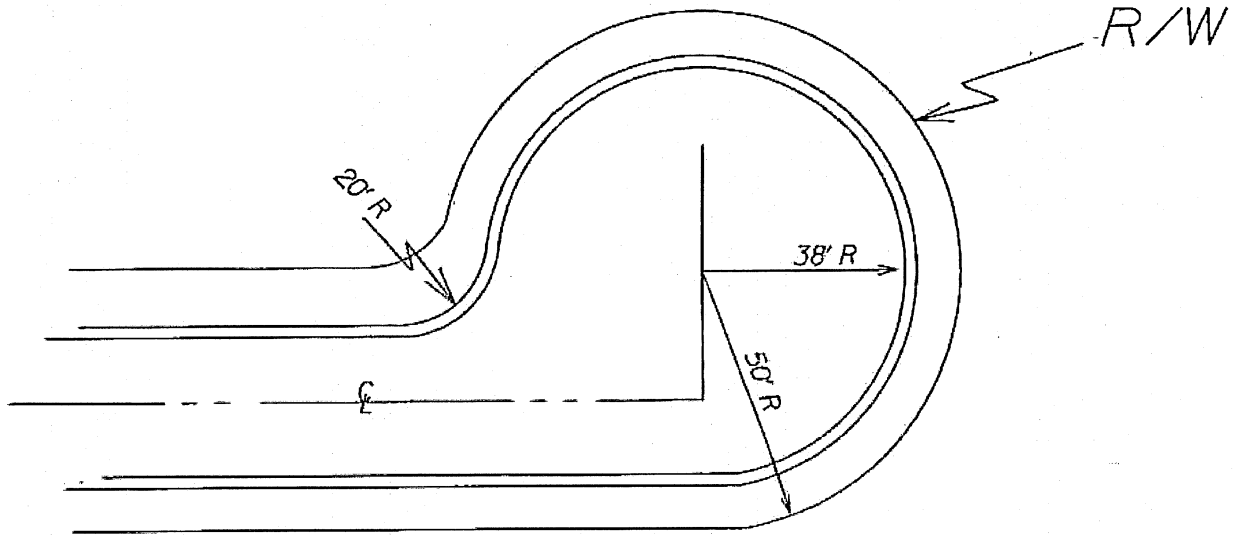

NOTE: COMMERCIAL CUL-DE-SAC TO HAVE 58 FOOT PAVED RADIUS. IF ANY ISLANDS ARE BUILT, THE RADIUS MUST BE 25 FEET OR GREATER AND IS SUBJECT TO REVIEW BY AUSTELL FIRE AND EMERGENCY SERVICE.



City of Opportunity. Moving Forward!

DETAIL 104(C) BUBBLE CUL-DE-SAC

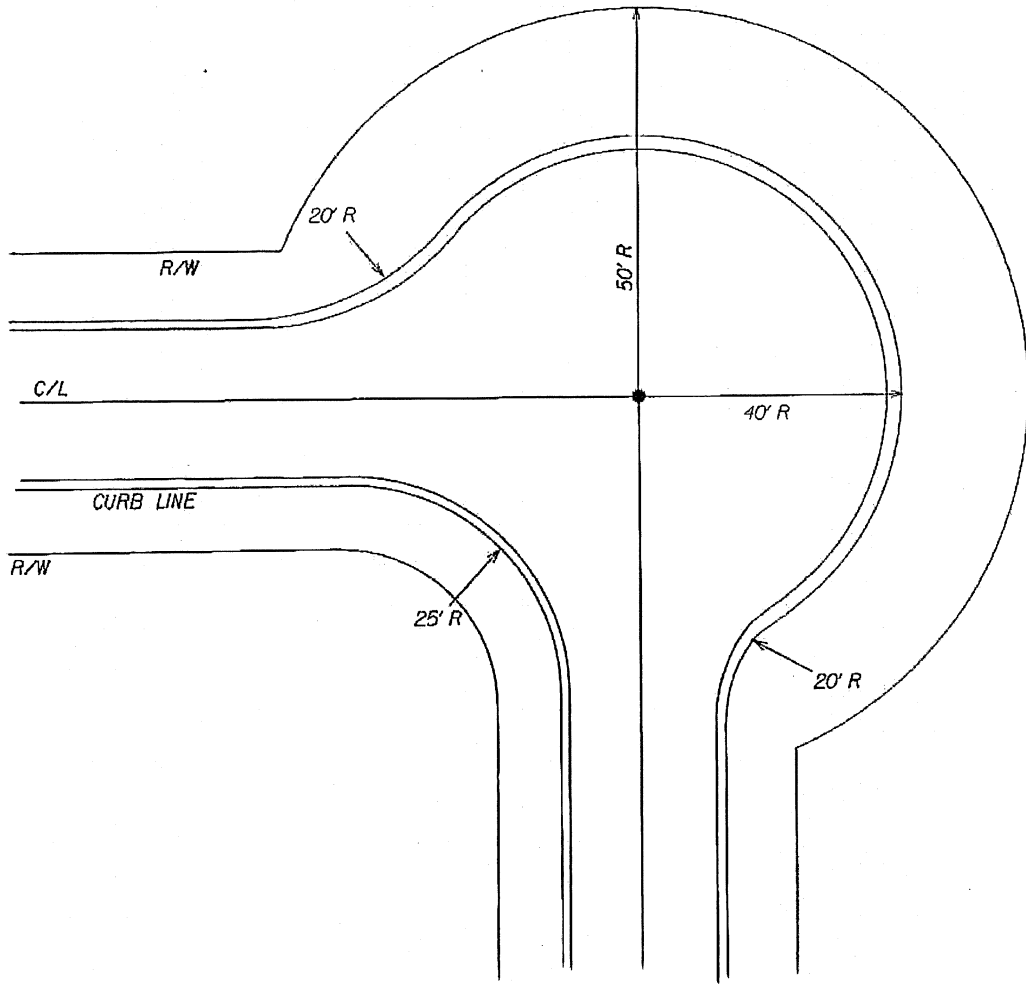

NOTE: ISLANDS ARE MAINTAINED BY THE HOMEOWNERS ASSOCIATION AND REQUIRES APPROVAL FROM AUSTELL FIRE AND EMERGENCY SERVICES.



City of Opportunity. Moving Forward!

DETAIL 106 CONCRETE CURBS AND MEDIANS

Right-In/Right-Out Drive Island

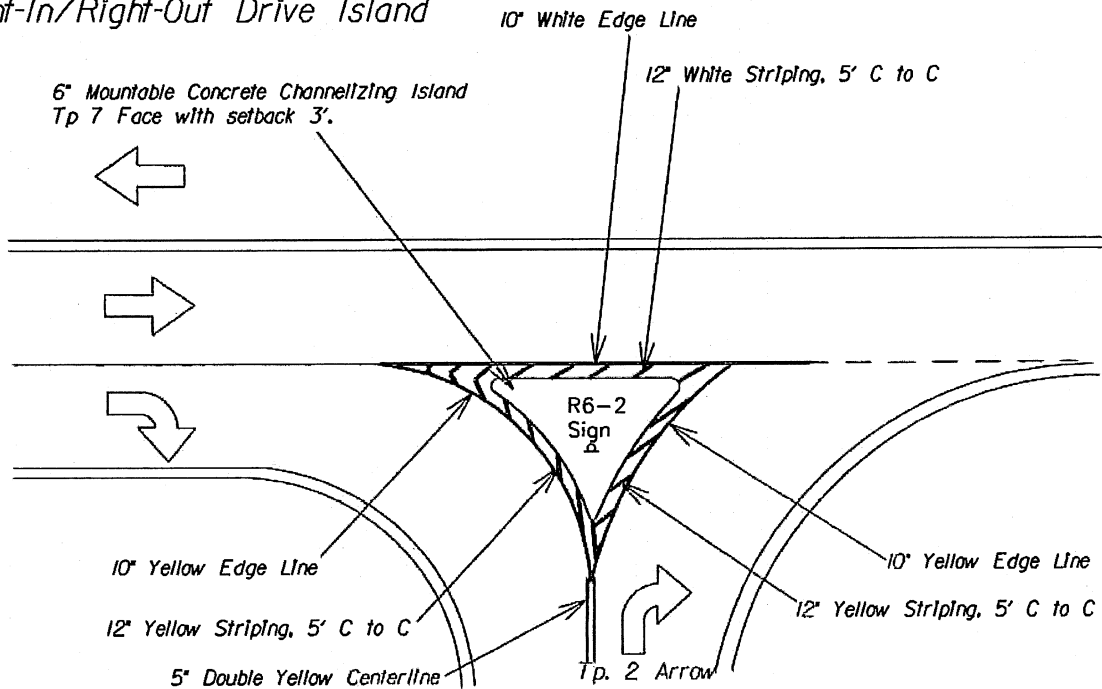

* 3 Bars at 11" C to C Both Ways

2/2, 6" X 6" Welded Wire Mesh

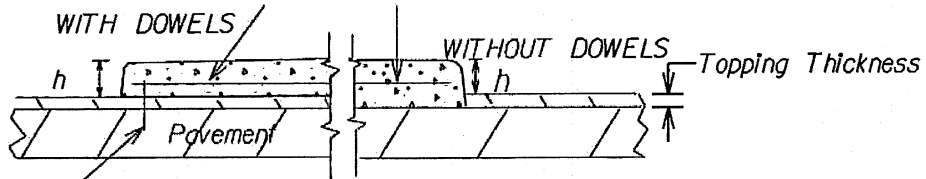

*4 Dowel Bars @ 3' C to C
4" FROM EDGE

CONCRETE MEDIANS (INTEGRAL)

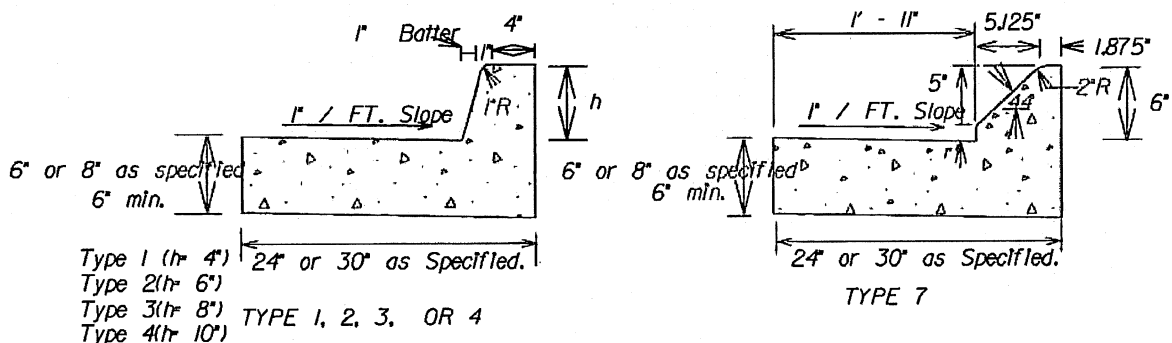

NOTE: 24" Curb will be allowed if 30" is not required by design, CDOT or if tying into 24".



City of Opportunity. Moving Forward!

DETAIL 107 STREET SIGN BASE

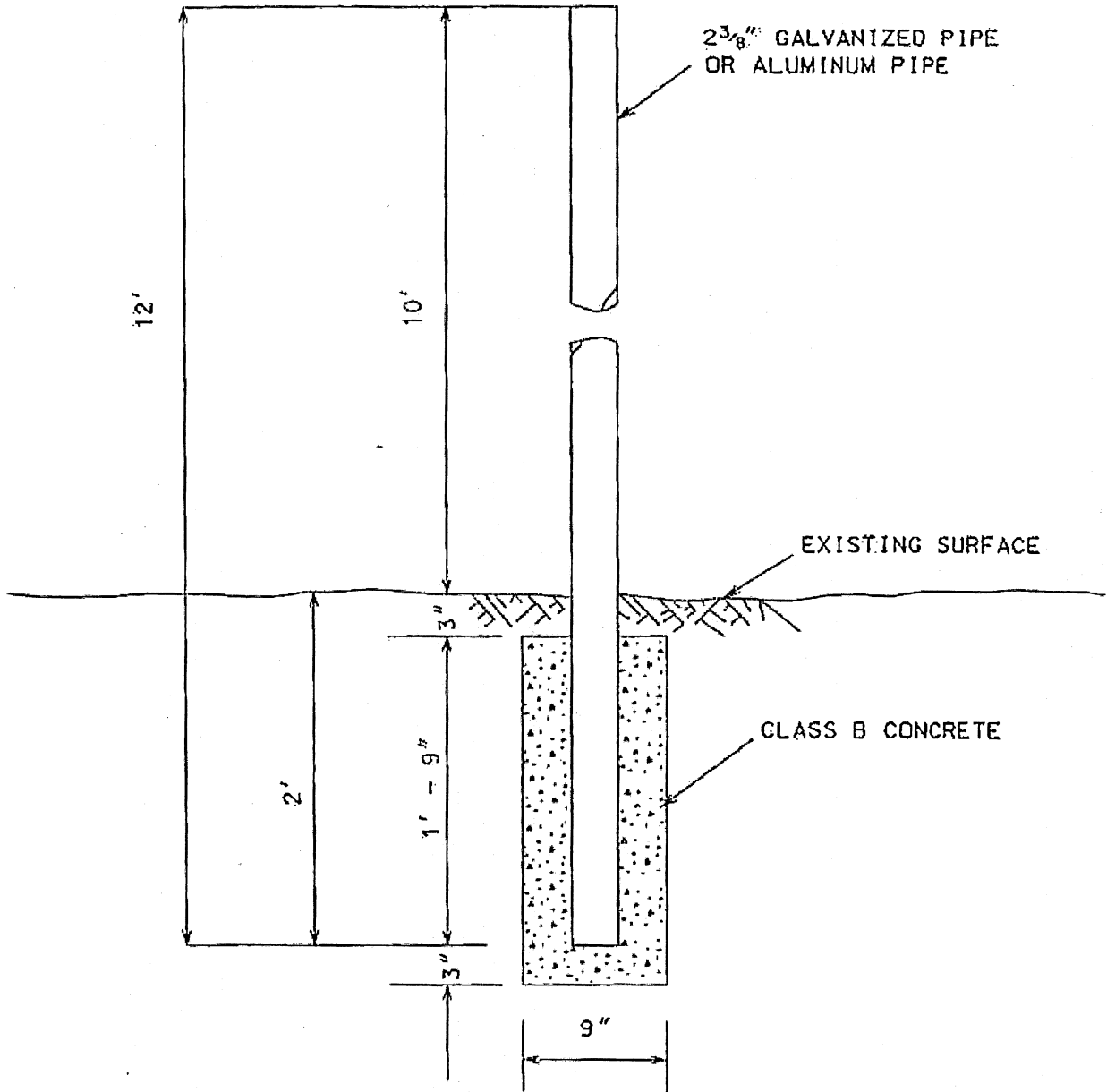

NOTE: Bottom of sign to be a minimum of 7' from ground.
Post to be 10' from edge of pavement.



City of Opportunity. Moving Forward!

DETAIL 108 STOPPING SIGHT DISTANCE REQUIREMENTS

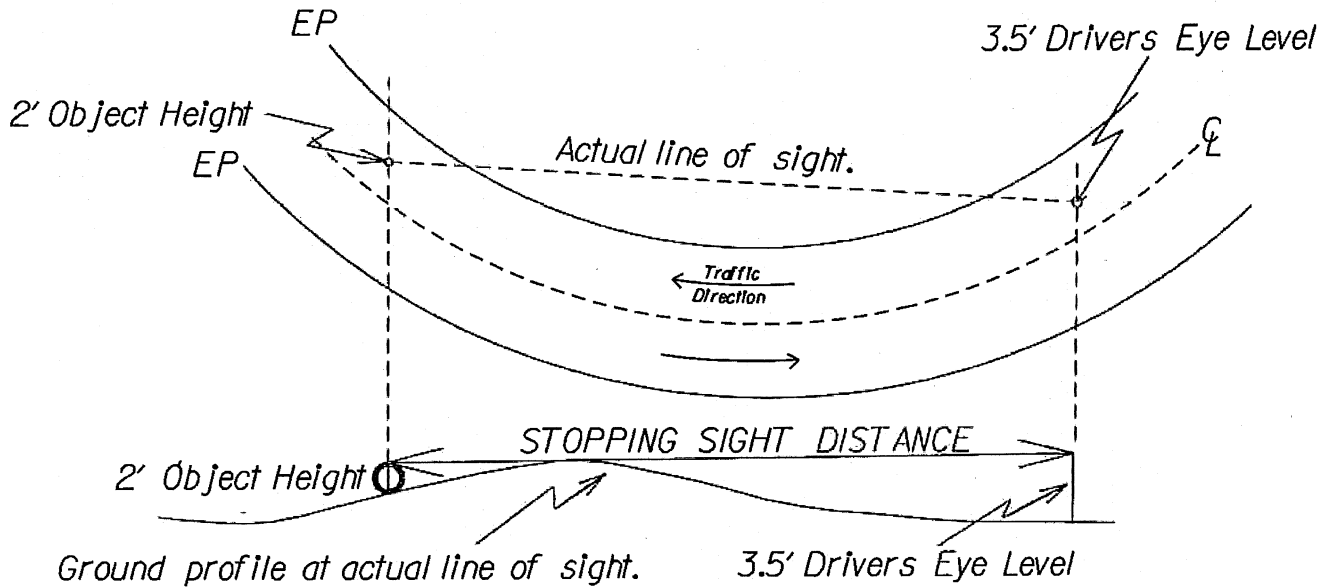

Examples of Horizontal and Vertical Sight Plans

STOPPING SIGHT DISTANCE REQUIRED IN FEET
DESIGN SPEED IN MPH SIGHT DISTANCE*

25	160'
30	200'
35	250'
40	305'
45	360'
50	425'
55	495'

SOURCE: 2004 AASHTO. SUBJECT TO CHANGE WITH AASHTO, LATEST EDITION.

STOPPING SIGHT DISTANCE IS THE DISTANCE REQUIRED TO SEE AN OBJECT TWO FEET IN HEIGHT FROM A DRIVERS EYE LEVEL OF 3.5 FEET IN HEIGHT TO STOP ON WET PAVEMENT.

★ STOPPING SIGHT DISTANCE MAY BE MODIFIED IN ACCORDANCE WITH AASHTO REVISIONS. AUSTELL PUBLIC WORKS MAY REQUIRE ADDITIONAL STOPPING SIGHT DISTANCE BASED ON EXCESSIVE GRADES, ETC. BASED ON AASHTO DESIGN.



City of Opportunity. Moving Forward!

DETAIL 109 OBSTRUCTING VIABILITY AT INTERSECTIONS

THERE SHALL BE NO STRUCTURE OR LANDSCAPING HIGHER THAN THREE FEET NOR ANY OBSTRUCTION OTHER THAN A POST OR TREE NOT EXCEEDING ONE INCH IN GREATEST CROSS-SECTIONAL DIMENSION BETWEEN A HEIGHT OF THREE FEET AND 15 FEET ABOVE THE ESTABLISHED GRADE OF EITHER STREET WITHIN AN AREA FORMED BY THE LOT LINES ON THE RIGHT-OF-WAY OF SUCH LOT AND A LINE JOINING POINTS ON SUCH LOT LINES LOCATED A DISTANCE OF 15 FEET FROM THE POINT OF THE RIGHT-OF-WAY AT INTERSECTION.

NOTE: MINIMUM INTERSECTION SIGHT DISTANCE SHALL BE MAINTAINED REGARDLESS OF BLOCKOUT ZONE.

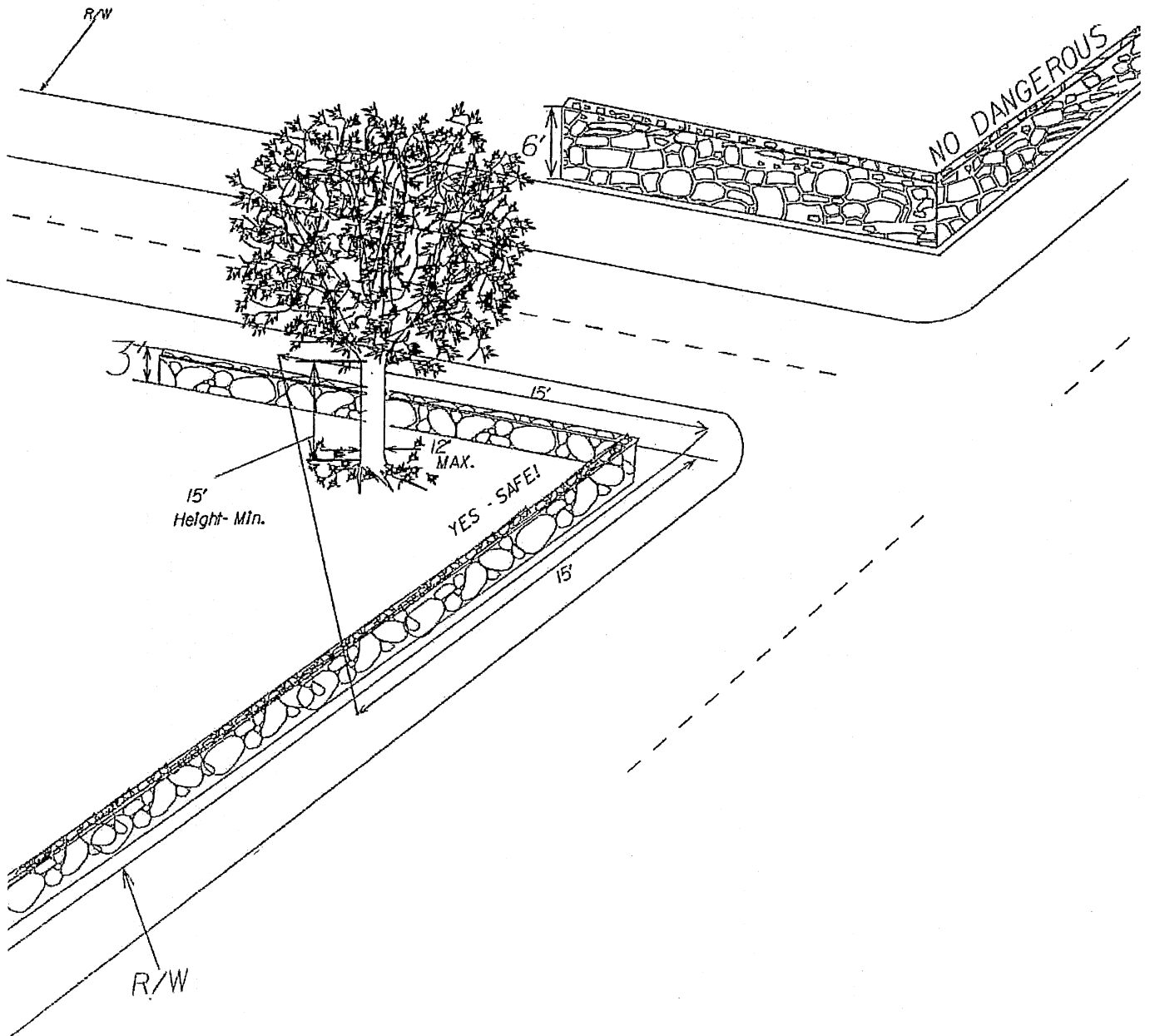



City of Opportunity. Moving Forward!

DETAIL 110 STREET BARRICADE

LENGTH OF OVERALL BARRICADE TO BE DETERMINED BY ACTUAL FIELD CONDITIONS

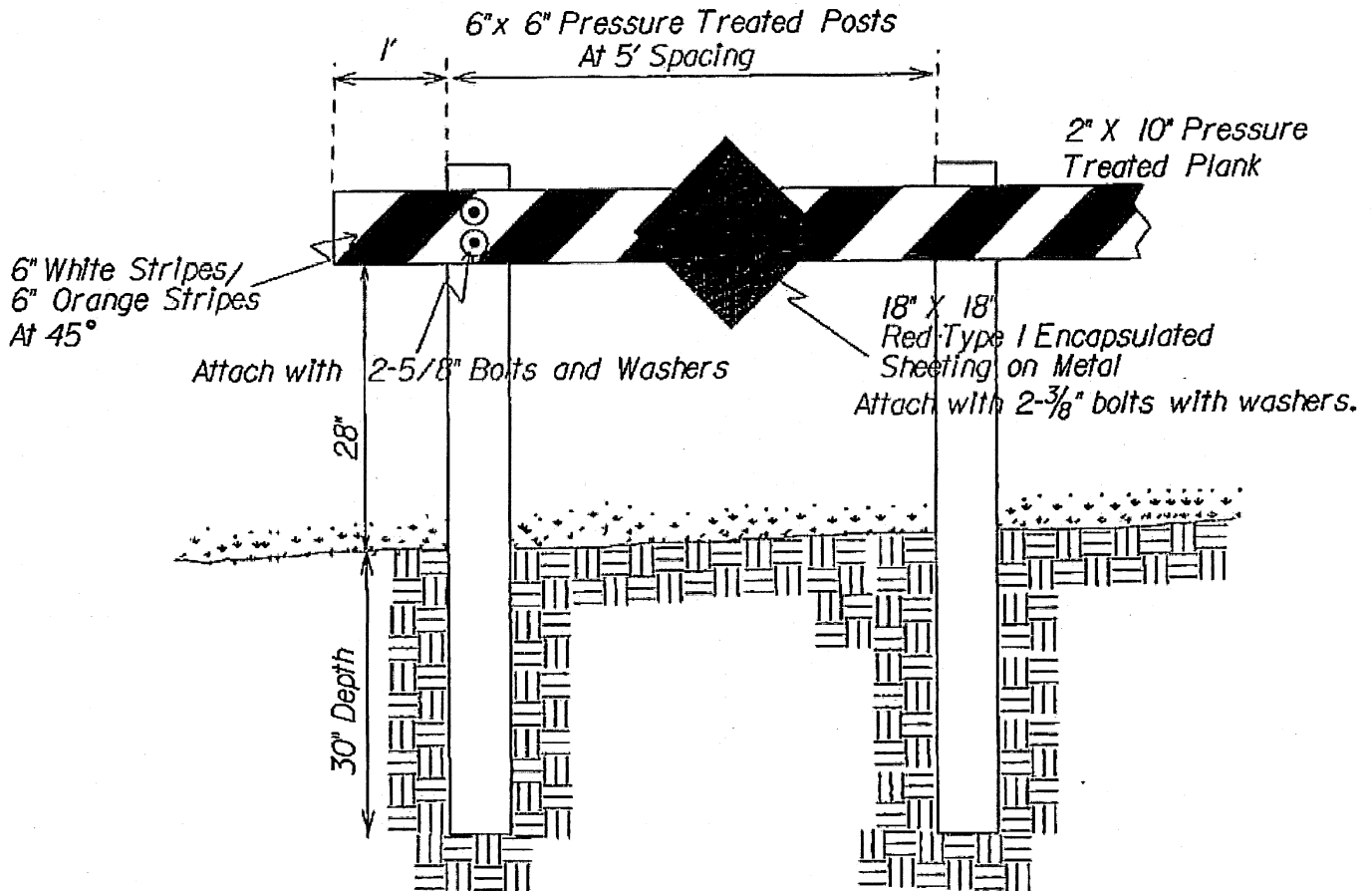

NOTE: GUARDRAIL CAN BE USED AS AN ALTERNATE.

POST SHALL BE GEORGIA DEPARTMENT OF TRANSPORTATION "TYPED" STEEL

PLANK SHALL BE GEORGIA DEPARTMENT OF TRANSPORTATION STANDARD W-BEAM 4011

WITH REFLECTORS IN LIEU OF CHEVRONS.



City of Opportunity. Moving Forward!

DETAIL 113 SIDEWALKS

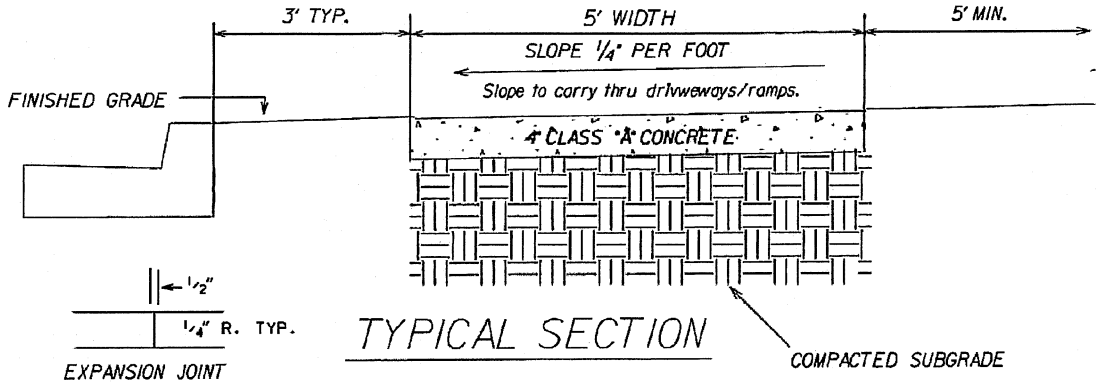

EXPANSION JOINT MATERIAL TO BE 1/2\" BITUMINUS PRODUCT.

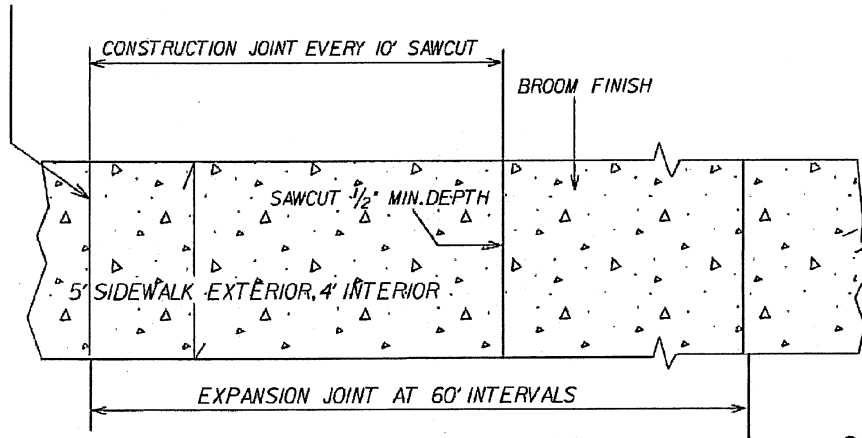

PLAN VIEW

SIDEWALK RAMP DETAIL

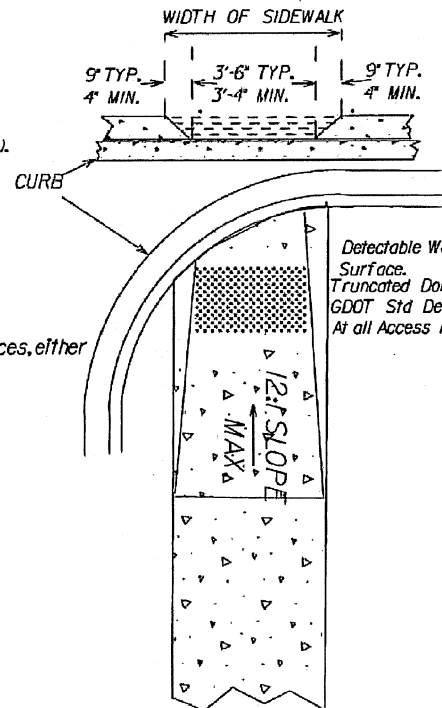

Maintain 2% Sidewalk/Shoulder cross-slope thru Driveways/Ramps.
To meet all ADA Standards.

NOTE: ACCESS RAMPS ARE TO BE PLACED AT ALL DRIVES, INTERSECTIONS AND AT ALL CURB ENCROACHMENTS. SEE GEORGIA DOT STANDARD A3 (FKA STANDARD 903W).

WHERE UTILITY STRUCTURES CONFLICT, WHERE SIDEWALK GEOMETRY VARIES AT SKEWED INTERSECTIONS OR IN OTHER SPECIAL CASES, THE SIDEWALK/RAMP MAY BE MODIFIED BY THE DESIGNER, PROVIDED THE WIDTH REMAINS CONSTANT AND NO PART OF THE RAMP IS STEEPER THAN 12%.

1/2\" EXPANSION MATERIAL SHALL BE PLACED WHERE SIDEWALK TIES INTO A STRUCTURE OR TERMINATES AT CURB, RAMPS OR DRIVEWAYS OR AT 60' MIN.

*Detectable Warning surface shall color contrast visually with adjoining surfaces, either light-on-dark or dark-on-light.

Detectable Warning Surface. Truncated Dome Per GDOT Std Detail A4 At all Access Ramps.



DETAIL 114 OFF STREET PARKING

City of Opportunity. Moving Forward!

Parallel Parking space

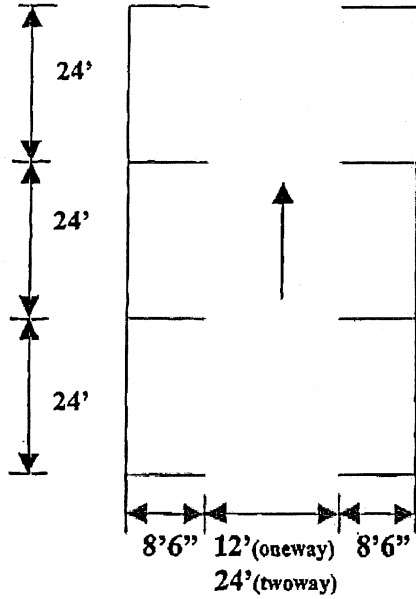

90° Parking space

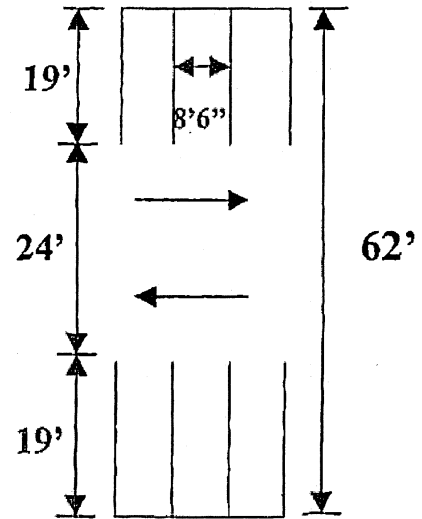

45° Parking space

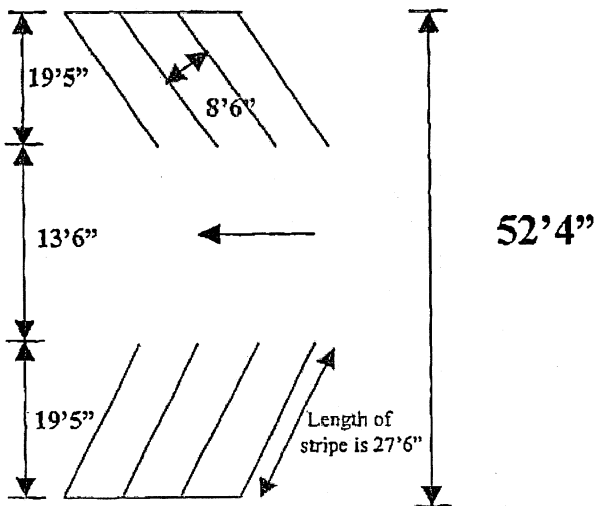

60° Parking space

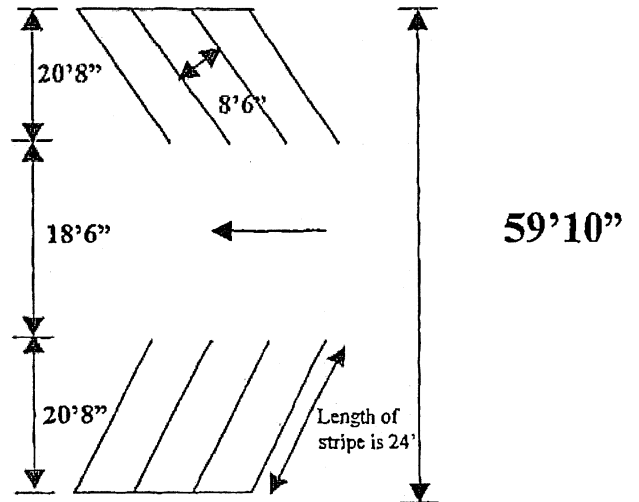



City of Opportunity. Moving Forward!

DETAIL 116 COMMERCIAL DRIVEWAY REQUIREMENTS

*NOTE: See section 402 for access restrictions to a thoroughfare.
Residential drive to be per GDOT STD.6050. See Section 402.07.01 for Specs*

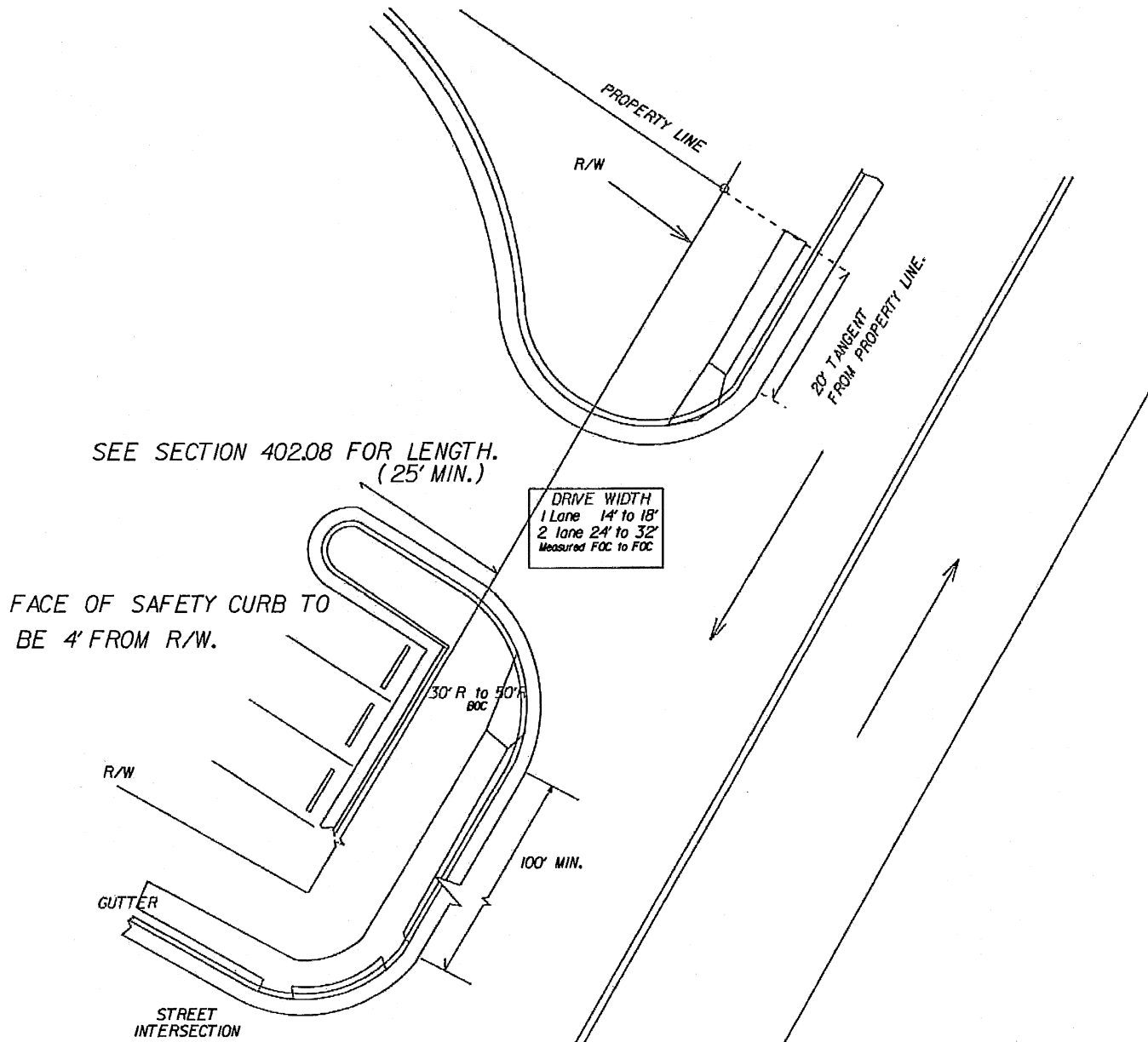

Ramps/sidewalk to meet ADA requirements for entire frontage, INCLUDING thru driveway.
Sidewalk/Ramps Cross-slope AND Driveway grade/Cross-slope not to exceed 1/4" per 1 Linear Foot.
Shoulder Cross-Slope to be 1/4" per 1 Linear Foot.



City of Opportunity. Moving Forward!

DETAIL 116R RESIDENTIAL DRIVEWAY STANDARD

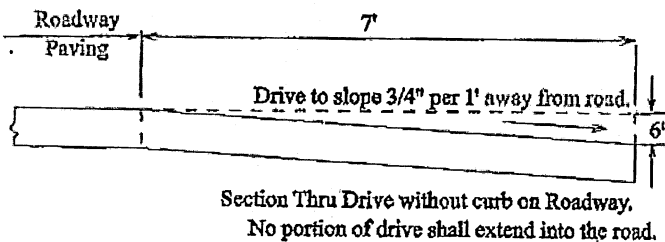
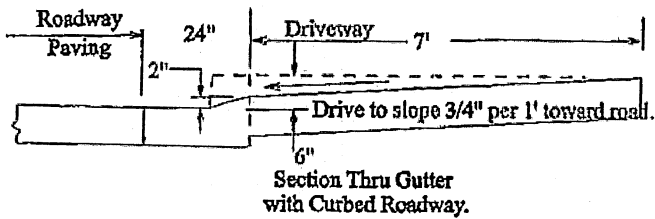
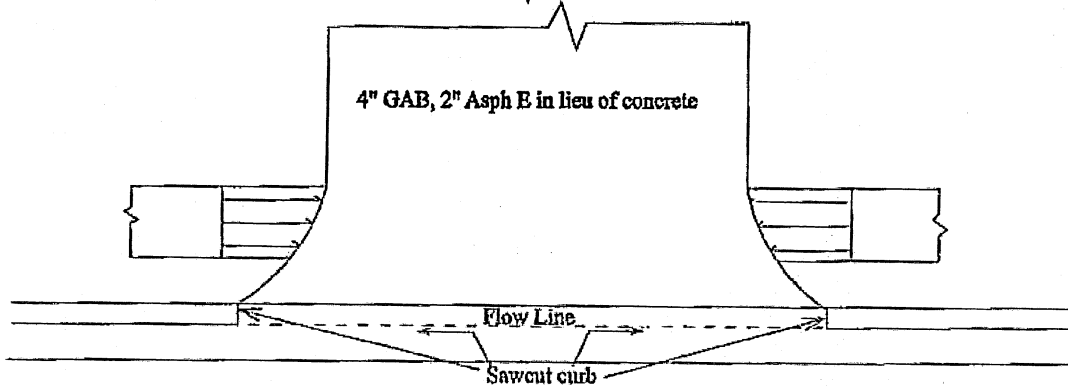
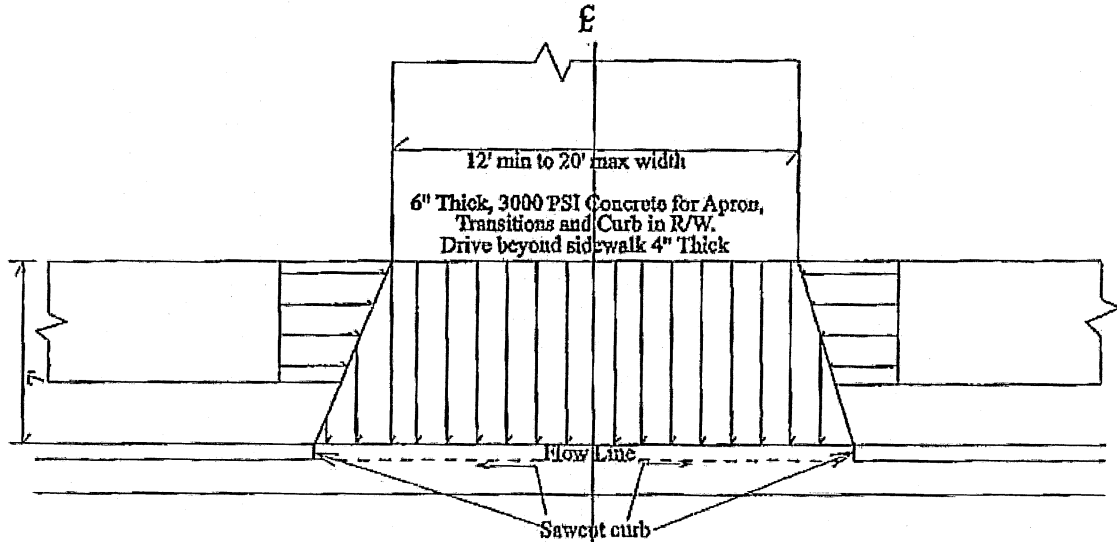

NOTES

1. Apron slope to match shoulder or 3/4" per LF.
2. See Cobb Detail 113 for access ramp spec.
3. Traffic control to meet MUTCD requirements.
4. Drive to be no closer than 50' to an adjacent intersection.
5. For access to a Major Thoroughfare submit to CDOT, Plan Review Division, for other requirements and review.
6. No structural obstructions (fences, Signs, Walls, irrigation) allowed in the R/W. Only low growing seasonal landscaping allowed.
7. Cobb County will not maintain driveway.
8. Lane Closure Permit is required from CDOT, Utility Division 770-528-1643.
9. Drainage structures are not allowed within drive limits. Conflicts to be reviewed by DOT.
10. Final appearance to have a smooth, solid, clean joint.



City of Opportunity. Moving Forward!

DETAIL 120 PATHWAYS

NOTE:
Landscaping to be approved by County Arborist
Drainage to be per roadway spec

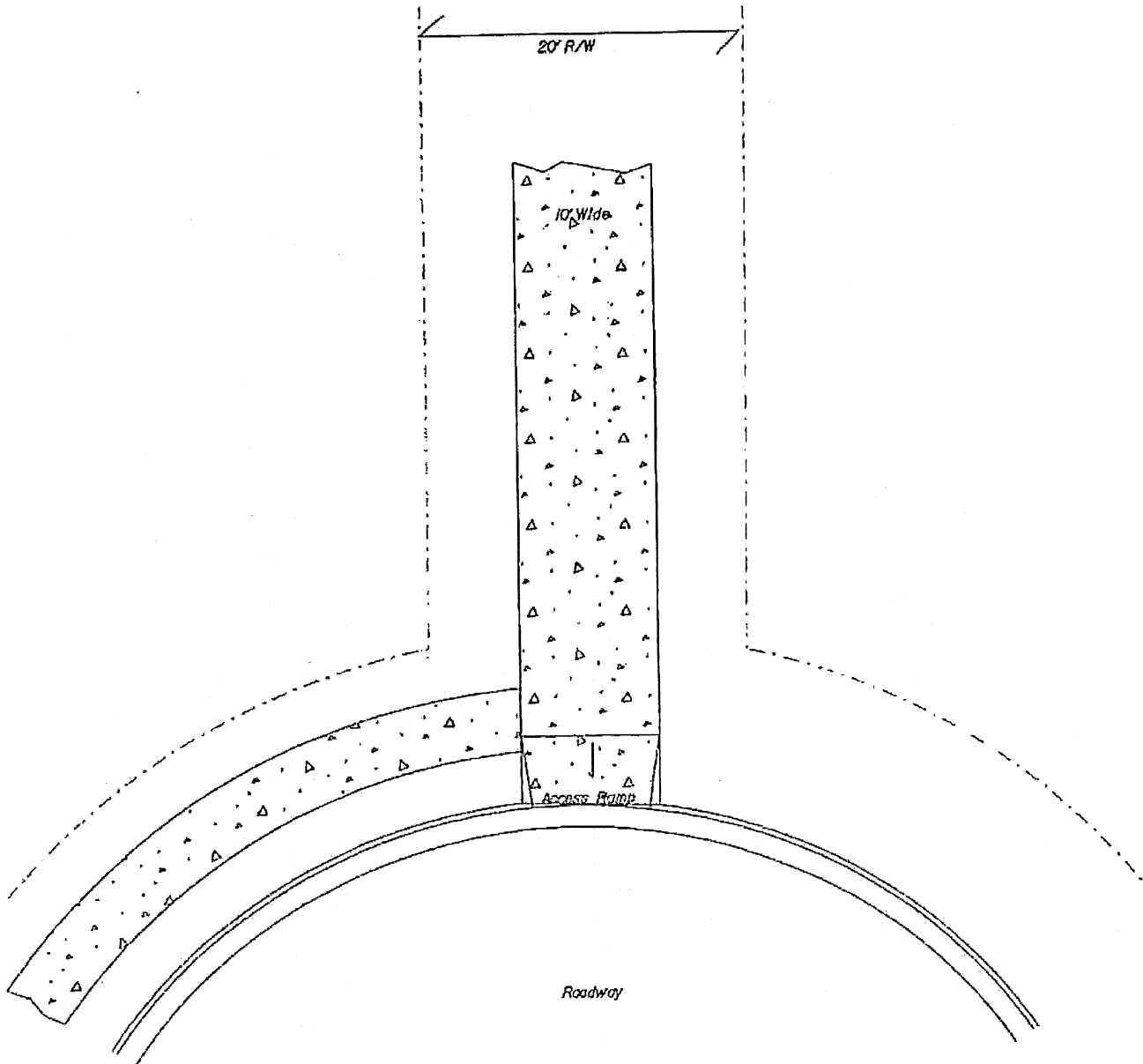
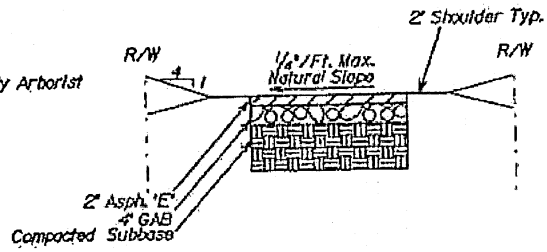



City of Opportunity. Moving Forward!

DETAIL 150 TRADITIONAL NEIGHBORHOOD DEVELOPMENT

Residential right-of-way signage to be placed by Austell Public Works. Aesthetic signs, at developers expense, may be approved through Austell Community Development, by permit only.

'Informal Parking' is allowed, but is not designated.
Residential access only.
20 MPH design speed.
125' Stopping Sight Distance.
90' Min. Centerline Radius.
15' Intersection Radius

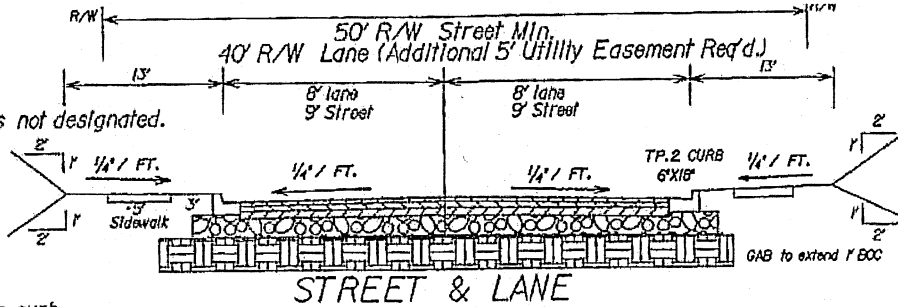

6' sidewalk required which abuts the curb.
Stopping Sight Distance required per Std. 108
Intersection Sight Distance required per Std. 401B
All landscaping and ISD shall be maintained by the HOA
Bike lane to utilize a different mix or color.
Streets with bike lanes shall have 28' min. width.
Planting strip behind the curb shall be 6' min.

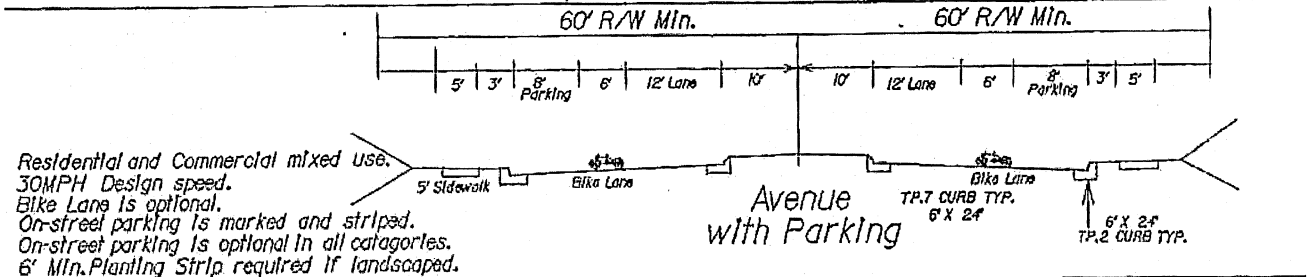
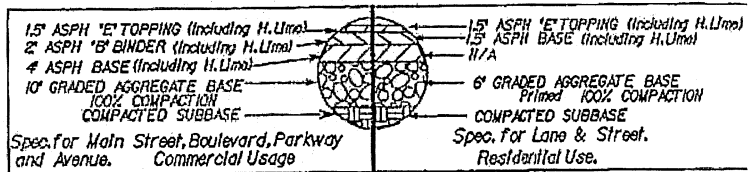

Residential and Commercial mixed use.
30MPH Design speed.
Bike Lane is optional.
On-street parking is marked and striped.
On-street parking is optional in all categories.
6' Min. Planting Strip required if landscaped.

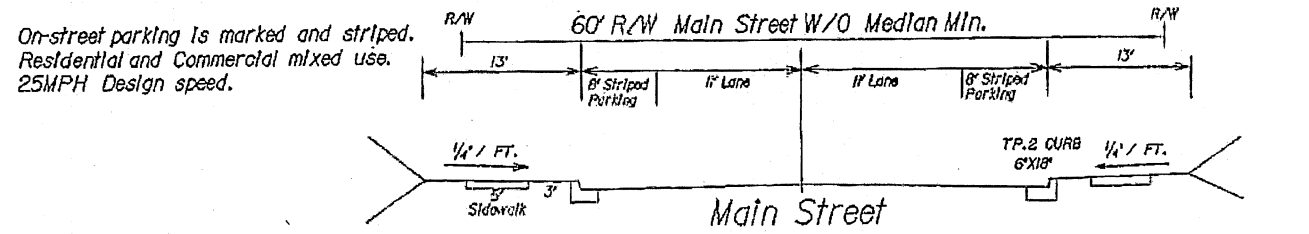

On-street parking is marked and striped.
Residential and Commercial mixed use.
25MPH Design speed.

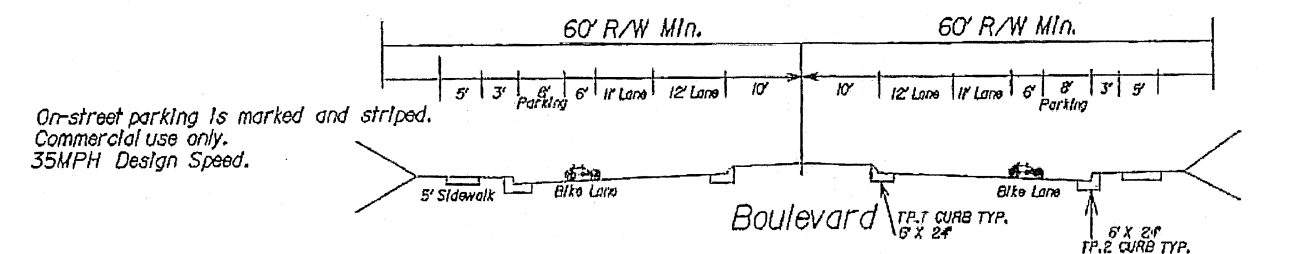

On-street parking is marked and striped.
Commercial use only.
35MPH Design Speed.

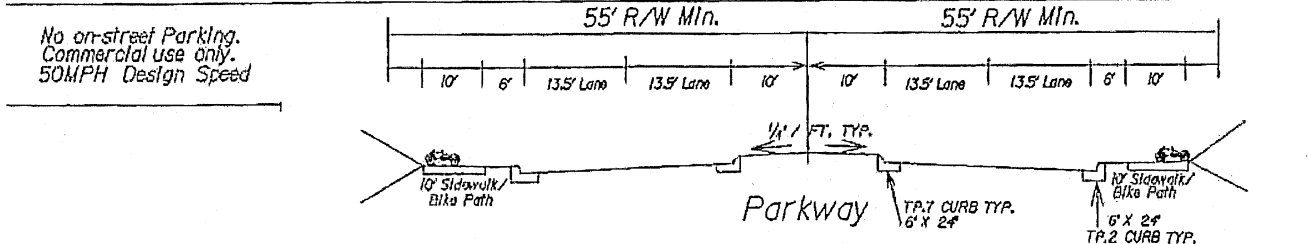

No on-street Parking.
Commercial use only.
50MPH Design Speed



City of Opportunity. Moving Forward!

DETAIL 401A ACCELERATION AND DECELERATION LANES

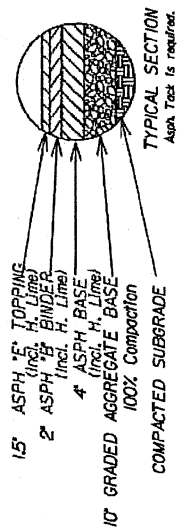
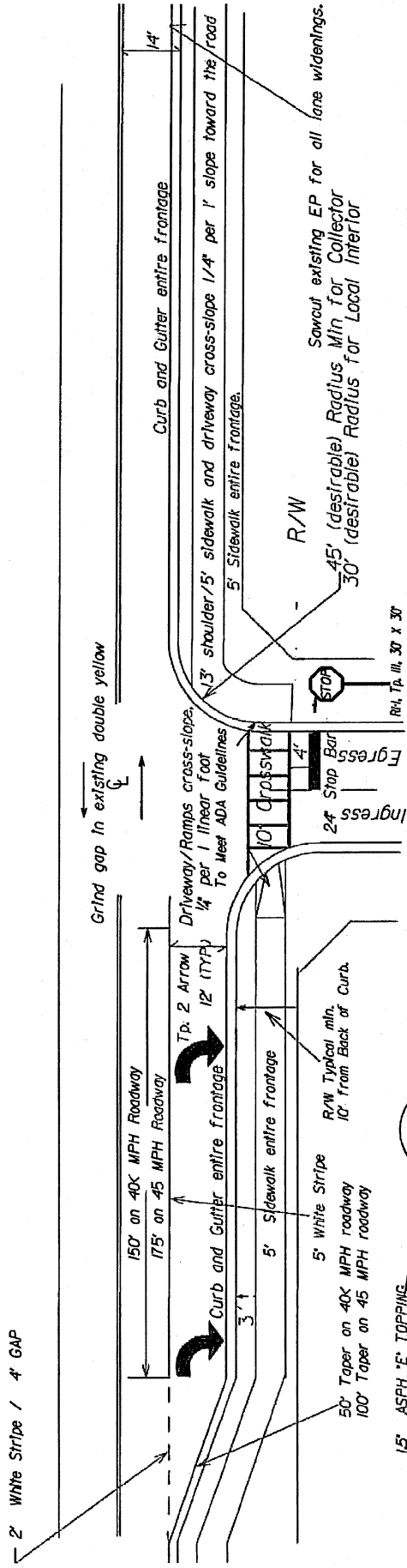

- 1) ALL PAVEMENT MARKINGS ARE TO BE THERMOPLASTIC.
 - 2) TRAFFIC CONTROL DEVICES, SIGNS, SIGNALS AND MARKINGS SHALL CONFORM TO * MANUAL OF UNIFORM TRAFFIC CONTROL DEVICES FOR STREETS AND HIGHWAYS (MUTCD) REQUIREMENTS, LATEST EDITION.
 - 3) SIDEWALK REQUIRED PER THE SIDEWALK ORDINANCE.
 - 4) ALL CONFLICTING MARKINGS ARE TO BE OBLITERATED AND DUPLICATE SIGNS REMOVED.
 - 5) ROAD FILL COMPACTION TO BE 95% UP TO TOP 12" AND 100% FOR TOP 12" (STD. PROCTOR)
 - 6) ALL EXTERIOR ROAD FRONTAGES ARE TO BE CURBED AND SIDEWALKED.
 - 7) NEW LANE CROSS-SLOPE TO MATCH EXISTING ROAD CROWN OR SUPERELEVATION.
 - 8) GAB to extend 1' behind curb.
 - 9) Guardrail is required where warranted per GDOT Sid or Site Inspector.
 - 10) ALL ACCESS POINTS/DRIVES ARE SUBJECT TO FURTHER RESTRICTION AS DEEMED NECESSARY BY CDOT OR GADOT TO INSURE SAFE, FUNCTIONAL DESIGN AND EFFICIENT OPERATION.
 - 11) ACCEL LANE MAY BE REQUIRED, ON A CASE BY CASE BASIS.
 - 12) All poles are to be 8' minimum from BOC.
 - 13) S/D street signage shall be provided by the developer.
- DEVELOPER TO SUBMIT NEW STREET SIGNAGE PLAN TO CDOT, OPERATIONS DIV, FOR REVIEW AND APPROVAL
FINAL PLAN SHALL BE HELD TILL APPROVED SIGNAGE IS IN PLACE. PER NOTE 2.



City of Opportunity. Moving Forward!

DETAIL 401B INTERSECTION SIGHT DISTANCE

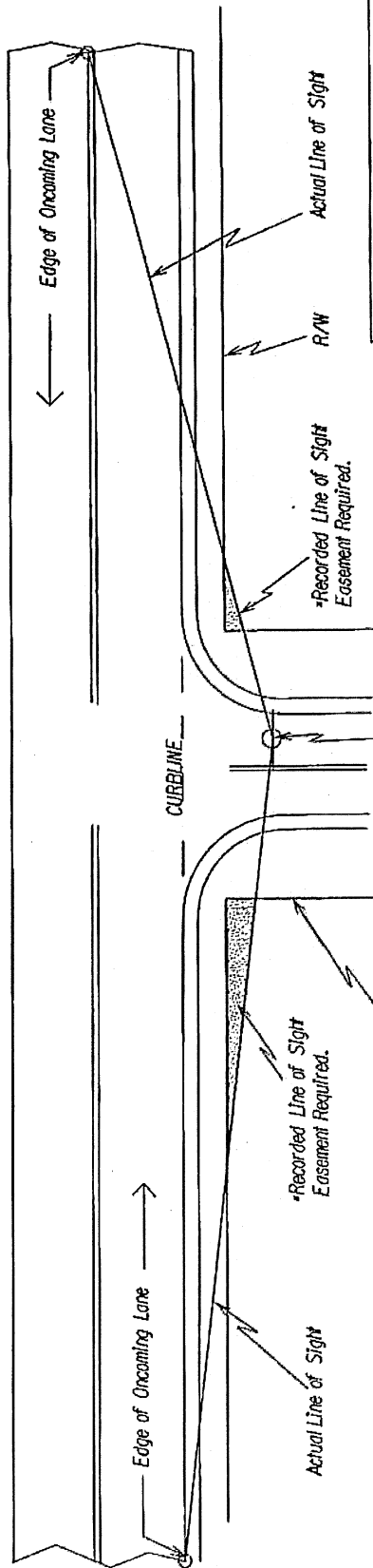
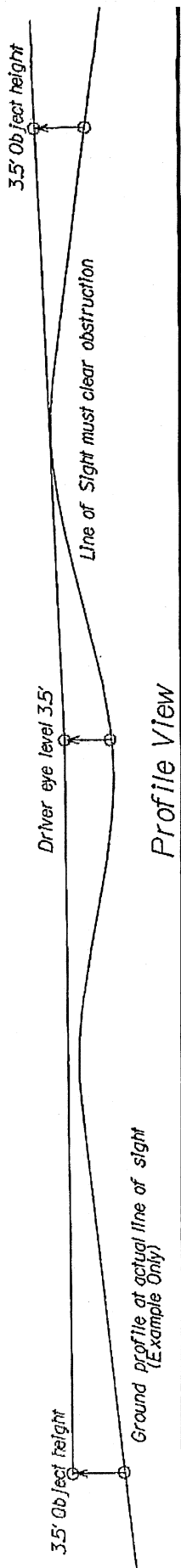

SPEED LIMIT	2 lane	3 & 4 lane	5 & 6 Lane
45 MPH	500'	560'	630'
40MPH	445'	500'	560'
35MPH	390'	440'	490'
30MPH	335'	---	---
25MPH	280'	---	---

Distances are for undivided roads.

Plan View

INTERSECTION SIGHT DISTANCE EASEMENTS ARE REQUIRED FOR AREAS OUTSIDE OF THE RIGHT-OF-WAY, LINE OF SIGHT EASEMENT SHOWN FOR EXAMPLE ILLUSTRATIVE PURPOSES ONLY. THE SPECIFIC LOCATION, CURVATURE OF ROADWAY, ETC. SHALL DETERMINE EASEMENT LIMITS. INTERSECTION SIGHT DISTANCE SHALL BE MEASURED FROM A POINT ESTABLISHED 15 FEET FROM THE CURB LINE OF THE EGRESS LANE, AT A HEIGHT 3.5 FEET ABOVE FINISHED GRADE. THE ACTUAL LINE OF SIGHT IS THEN EXTENDED IN A STRAIGHT LINE, THE MINIMUM REQUIRED DISTANCE TO BOTH SIDES OF THE ABUTTING STREET ALONG THE THOROUGHFARE TO THE EDGE OF THE ONCOMING TRAVEL LANE OF THREAT, TERMINATING AT A POINT 3.5 FEET ABOVE FINISHED GRADE. APPROACH GRADES ARE TO BE SHOWN ON PROFILE. APPROACH GRADES OF 3.1% UP TO 12% ARE TO BE INCREASED BY 10%. APPROACH GRADES EXCEEDING 12.1% SHALL BE REVIEWED BY AUSTELL PUBLIC WORKS. FURTHER CALCULATION FACTORS, TYPE OF VEHICLES, LANES CROSSED, DIVIDED MEDIAN, ETC. ARE TO BE CONSIDERED IN THIS REQUIREMENT. AUSTELL PUBLIC WORKS RESERVES THE RIGHT TO MAKE ADJUSTMENTS BASED ON AASHTO REQUIREMENTS, LATEST EDITION.



City of Opportunity. Moving Forward!

DETAIL 401C THREE LANE URBAN TYPICAL SECTION

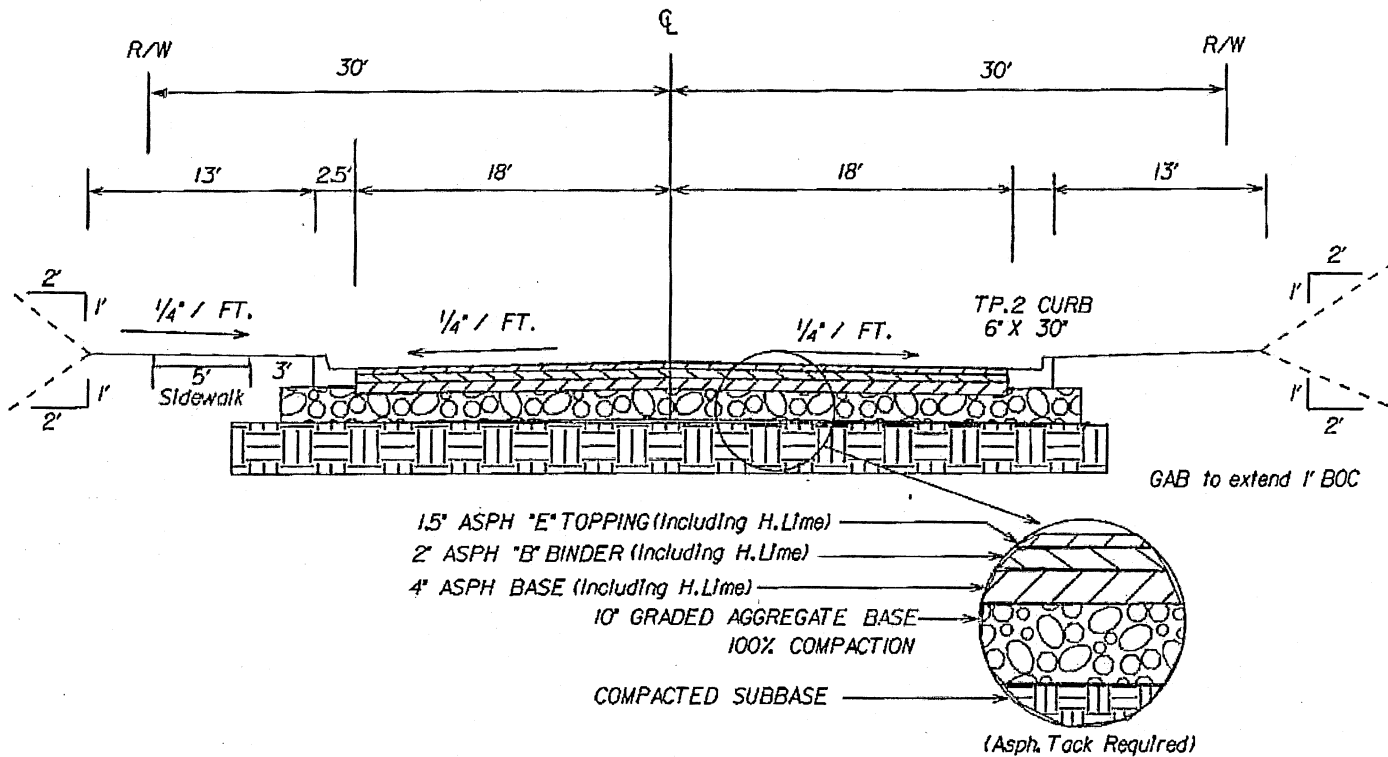

NOTE:

- 8 INCH CURB MAY BE REQUIRED BY GEORGIA DEPARTMENT OF TRANSPORTATION.
- MEDIAN AREAS LESS THAN SEVEN FOOT WIDE ARE TO HAVE A FOUR FOOT MEDIAN PAVING.
- PAVING SPECIFICATIONS IS FOR ALL DEDICATED COMMERCIAL/INDUSTRIAL ROADS AND ACCELERATION/DECELERATION LANES AND ROAD WIDENINGS.
- 24 INCH CURB TO BE ALLOWED IF NOT REQUIRED BY DESIGN, AUSTELL PUBLIC WORKS, OR IF TIEING INTO 24 FOOT.
- ROAD FILL COMPACTION TO BE 95% UP TO TOP 12 INCHES AND 100% FOR TOP 12 INCHES (STANDARD PROCTOR).
- ALL ROAD CONSTRUCTION, MATERIALS, AND METHODS ARE SUBJECT TO TESTING AND TOLERANCES IN ACCORDANCE WITH GEORGIA DEPARTMENT OF TRANSPORTATION STANDARD SPECIFICATIONS, LATEST EDITION.
- GUARDRAIL IS REQUIRED PER AASHT SPECIFICATIONS OR SITE INSPECTOR MEETING GEORGIA DEPARTMENT OF TRANSPORTATION SPECIFICATIONS.



City of Opportunity. Moving Forward!

DETAIL 401D FOUR LANE DIVIDED HIGHWAY WITH 20 FOOT MEDIAN

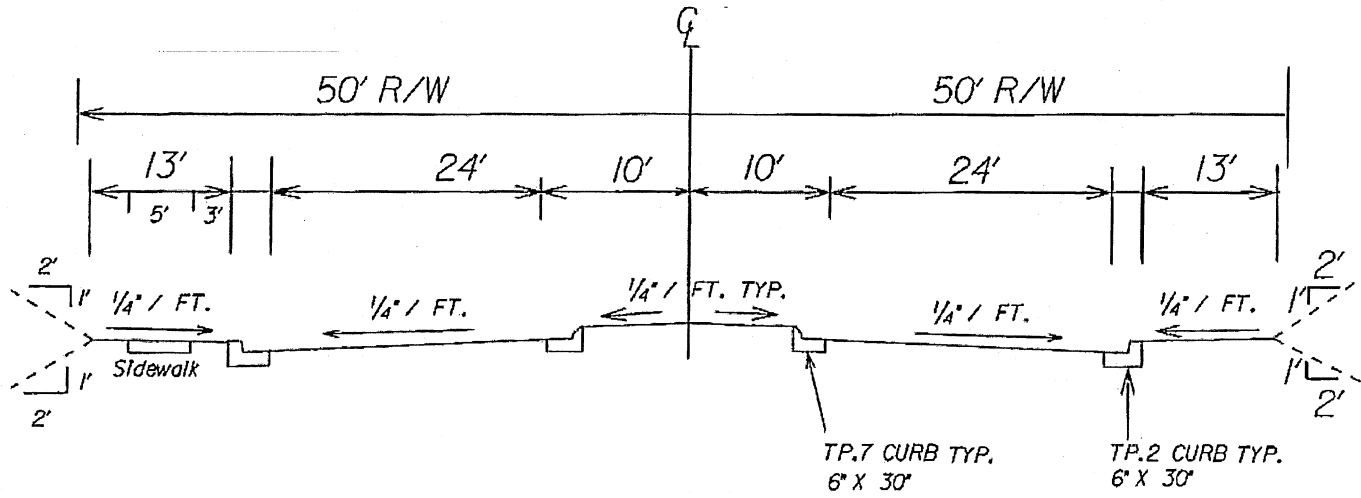



City of Opportunity. Moving Forward!

DETAIL 401E FIVE LANE URBAN TYPICAL SECTION

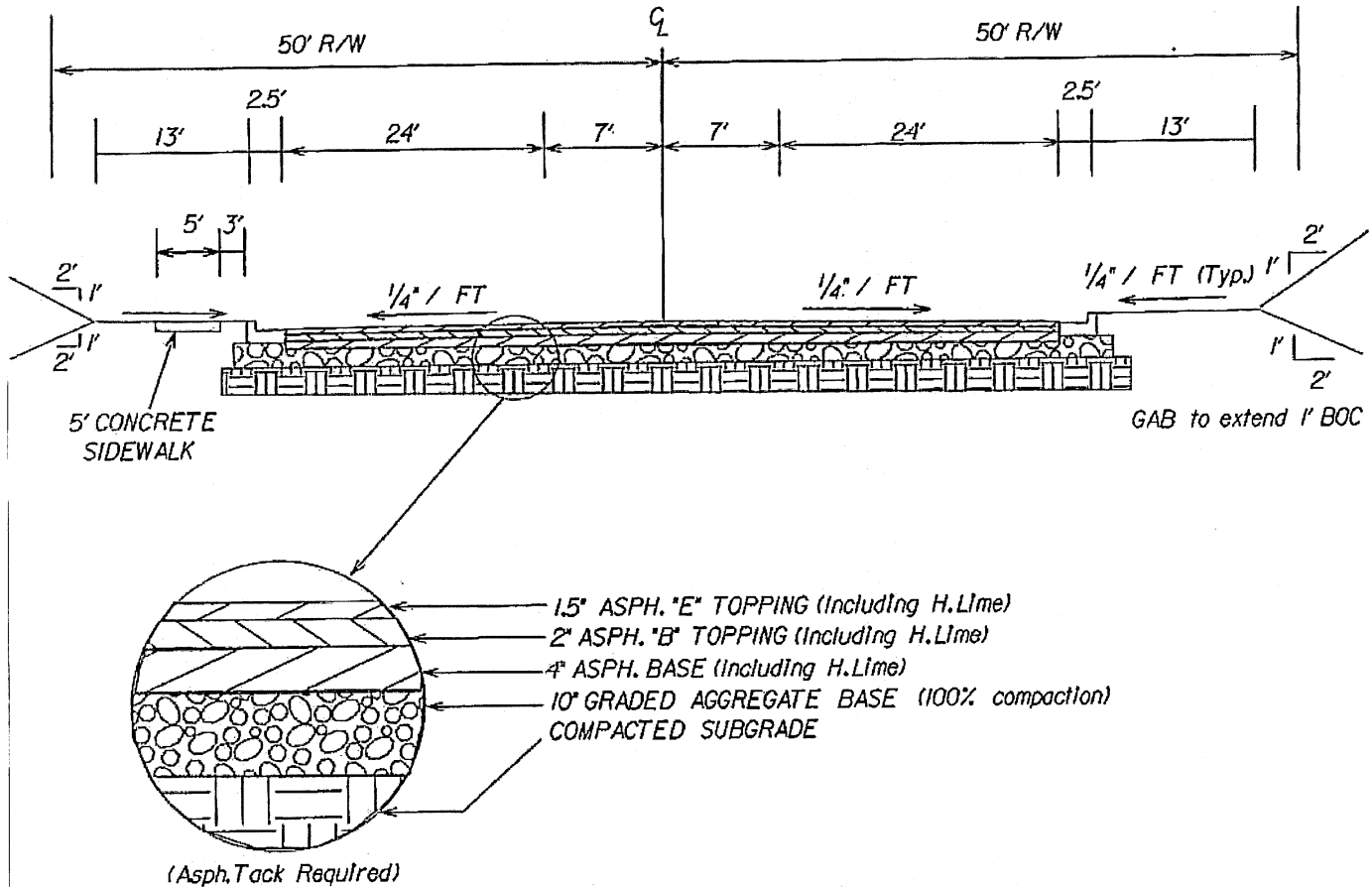

NOTE:

- 8 INCH CURB MAY BE REQUIRED BY GEORGIA DEPARTMENT OF TRANSPORTATION.
- 24 INCH CURB TO BE ALLOWED IF NOT REQUIRED BY DESIGN, AUSTELL PUBLIC WORKS, OR IF TIEING INTO 24 FOOT.
- ROAD FILL COMPACTION TO BE 95% UP TO TOP 12 INCHES AND 100% FOR TOP 12 INCHES (STANDARD PROCTOR).
- GUARDRAIL IS REQUIRED AS WARRANTED BY GEORGIA DEPARTMENT OF TRANSPORTATION OR SITE INSPECTOR.



City of Opportunity. Moving Forward!

DETAIL 401F LEFT TURN LANE TYPICAL SECTION

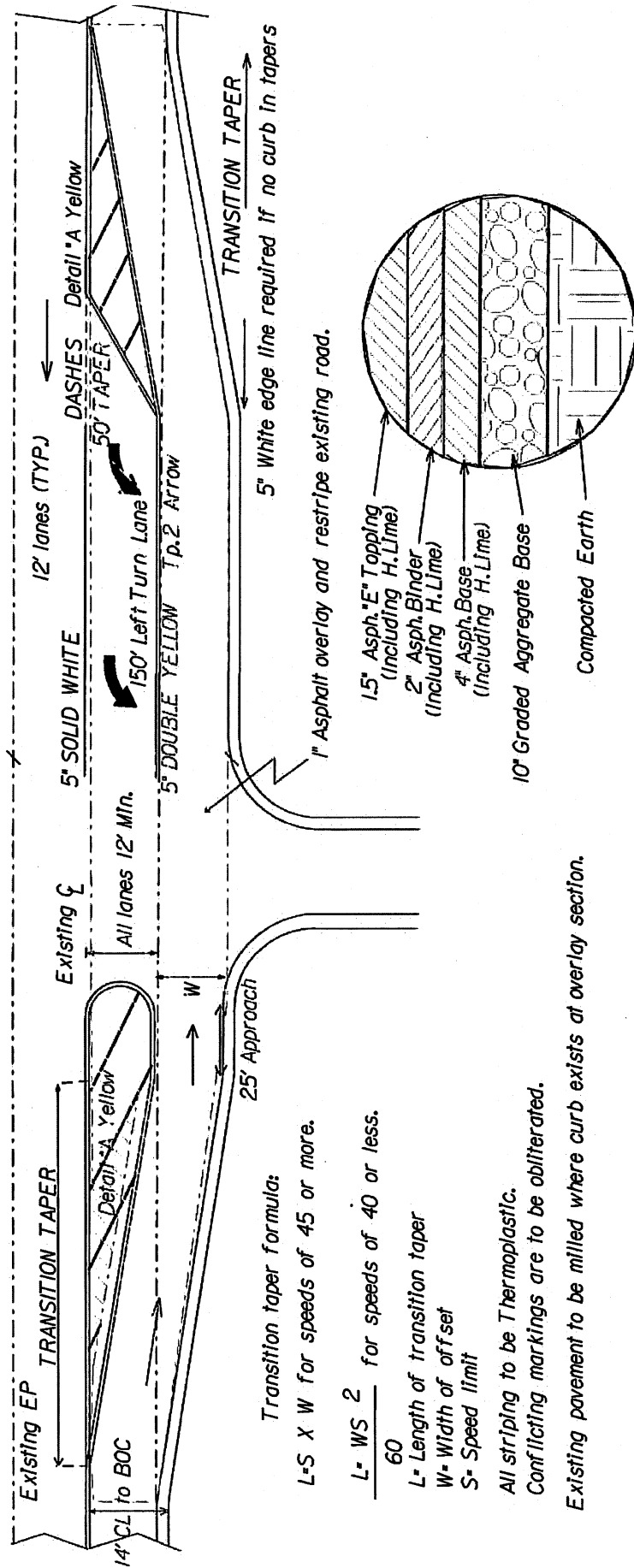

Transition taper formula:

$L = S \times W$ for speeds of 45 or more.

$L = \frac{WS^2}{60}$ for speeds of 40 or less.

L = Length of transition taper

W = Width of offset

S = Speed limit

All striping to be Thermoplastic.

Conflicting markings are to be obliterated.

Existing pavement to be milled where curb exists at overlay section.



City of Opportunity. Moving Forward!

DETAIL 4-01P PAVEMENT MARKING DETAILS

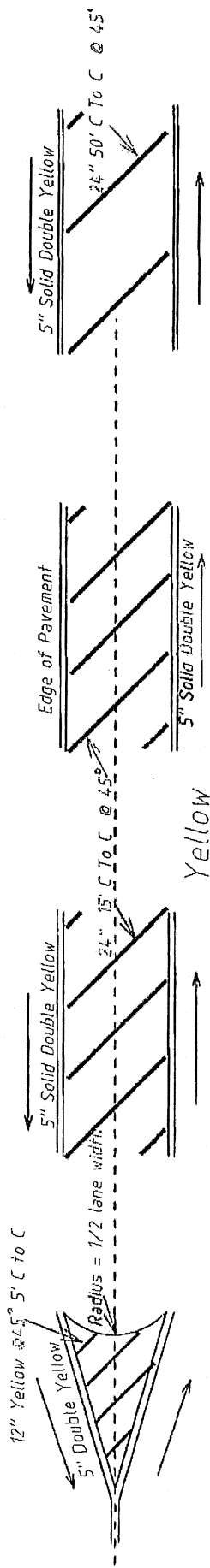

Detail A

Detail B

Detail C

Detail D

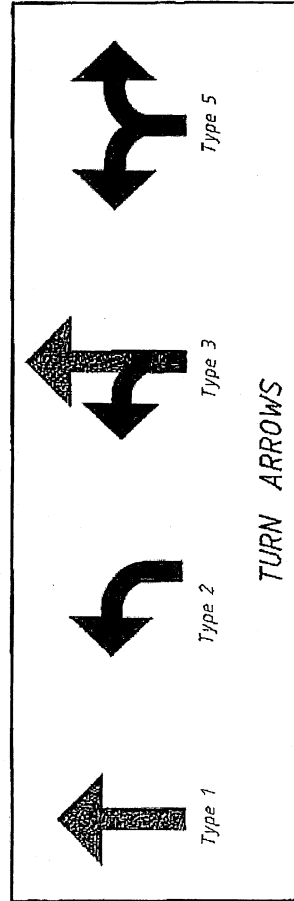
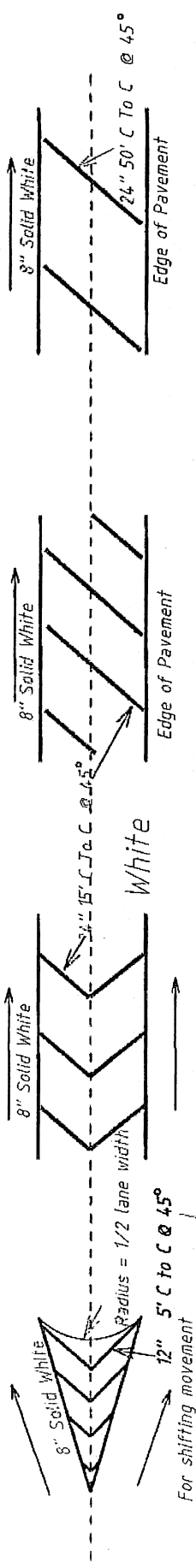

NOTES

← Traffic Flow

All Striping to be Thermoplastic
Arrow dimensions per GDOT Spec.
C to C = Center to Center



City of Opportunity. Moving Forward!

STOP BAR and CROSSWALK DETAIL

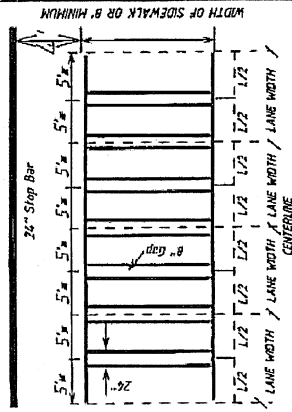

USED WHEN THE LANE WIDTH EXCEEDS 12' OR NO STRIPES EXIST.
 All Striping & Solid White Thermoplastic

Stop Bar and Crosswalk are required if:
 1) A D.A. Signal.
 2) A Midway Stop (M.S.). If sidewalk exists.

LEGEND

- ◇ TYPE 1 TWO-WAY YELLOW RPM
 - ◇ TYPE 1 TWO-WAY WHITE RPM
 - ◁ TYPE 2 ONE-WAY YELLOW RPM
 - ◁ TYPE 2 ONE-WAY WHITE RPM
 - ◁ TYPE 3 WHITE/RED RPM
 - DIRECTIONAL ARROW
 - PAVEMENT ARROW
 - TYPE 10 8" REFLECTIVE WHITE SYMMETRIC MARKER
 - SKIP LINE OR SOLID LINE
- NOTE: ALL RPM'S SHALL BE STIMSONITE 948 OR EQUAL.

DETAIL 401R RAISED PAVEMENT MARKERS

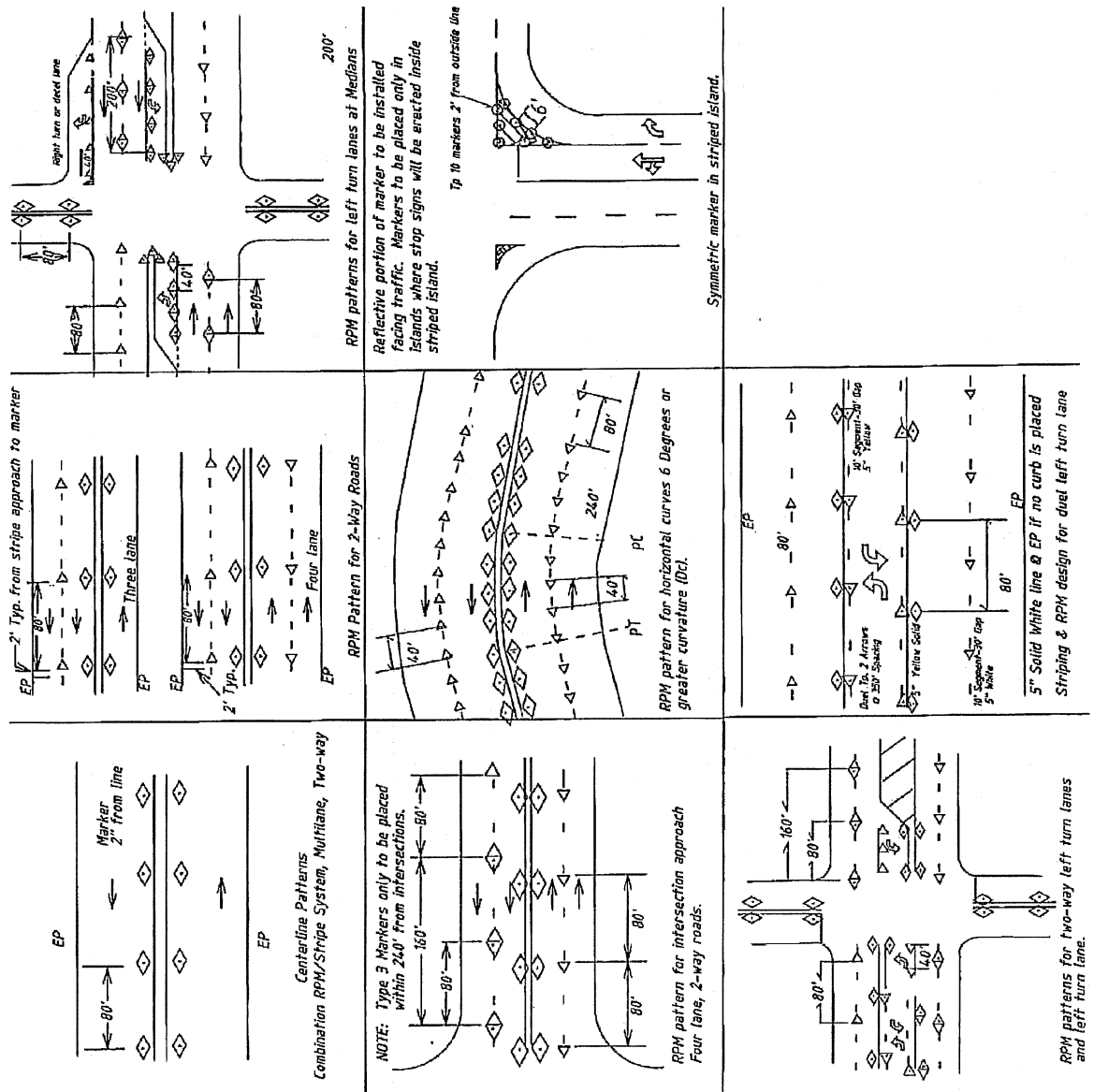



City of Opportunity. Moving Forward!

DETAIL 416-1 TREE PLANTING TYPICAL SECTION

CROWN

Set and maintain tree in a plumb vertical position. Prune all dead, damaged or crossing branches and all waterspouts and suckers. Do not cut central leader or other branch tips.

ORGANIC MULCH

2" to 4" deep to limits of cultivated area. Keep 2" away from trunk.

ROOT BALL

Remove all strapping. Cut and remove as much wire basket as possible. Fold down and bury top half of burlap. Cut encircling roots (container-grown trees).

WATER RING

Use only if trees are to be hand watered with a hose. Build no higher than 3" and place just beyond root ball. Destroy after one growing season.

CULTIVATED AREA

Area of soil to be tilled. If soil amendments are deemed necessary, apply to this entire area as well as the planting hole.

PLANTING HOLE

Dig only deep enough to have top of root ball at grade or 2" higher in heavy or poorly drained soils. Slope sides 45° and scarify if necessary. Set root ball on solid ground.

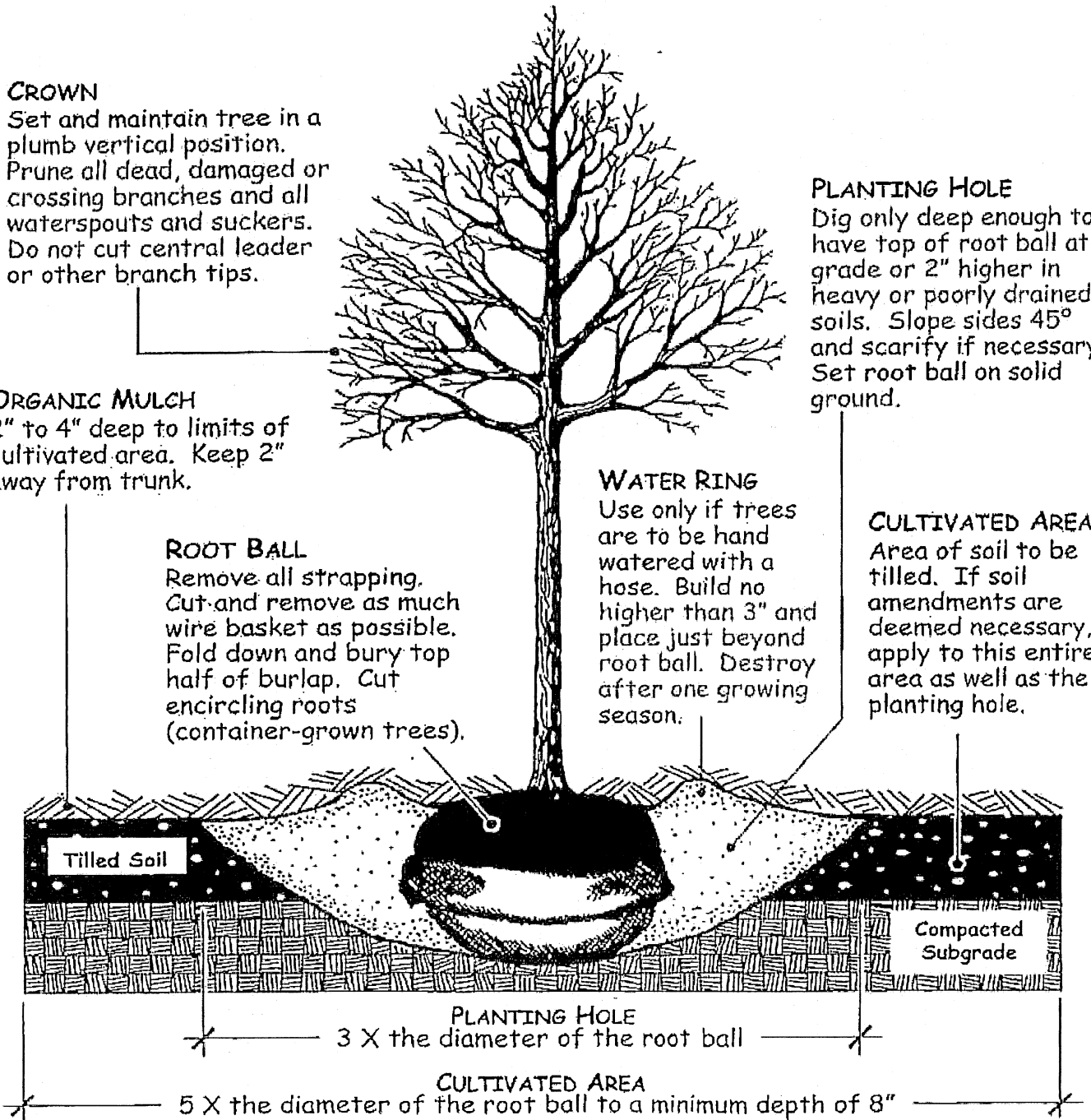



City of Opportunity. Moving Forward!

DETAIL 416-2 TREE ANCHORING - TYPE A TYPICAL SECTION

ATTACHMENT HEIGHT
Attach at approximately
1/3 the height of the
main stem.

STAKE
1" x 2" wooden stake. Install
so that stake does not touch
trunk or any branches. Place on
windward (west) side of trunk
so tree blows away from stake
during prevailing summer winds.

STRAP
Wide, soft, flexible
material such as woven
polypropylene. Do not use
hose and wire. Wrap in
figure 8 to prevent stake
from rubbing tree trunk.

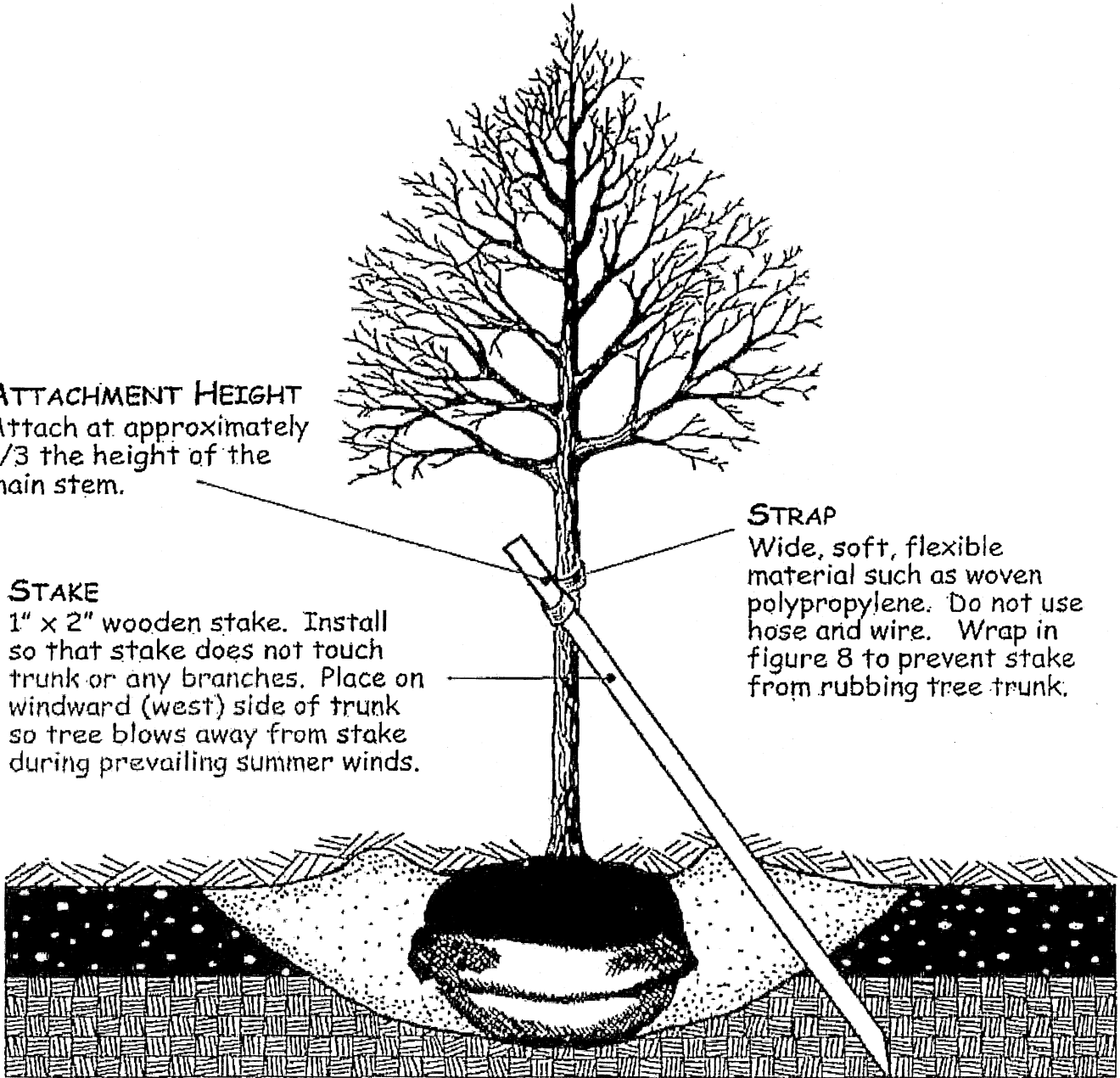

Use anchoring systems only where wind or soil
conditions make it necessary. Remove after one year.



City of Opportunity. Moving Forward!

DETAIL 416-3 TREE ANCHORING - TYPE B TYPICAL SECTION

STAKES

2" x 2" x 5' wooden stakes or 5' long metal fence posts. Place perpendicular to prevailing summer winds.

STRAPS

Wide, soft, flexible material manufactured for the purpose of tree anchoring. Two examples shown here are a woven polypropylene webbing and a rubber strip with grommets for wire attachment.

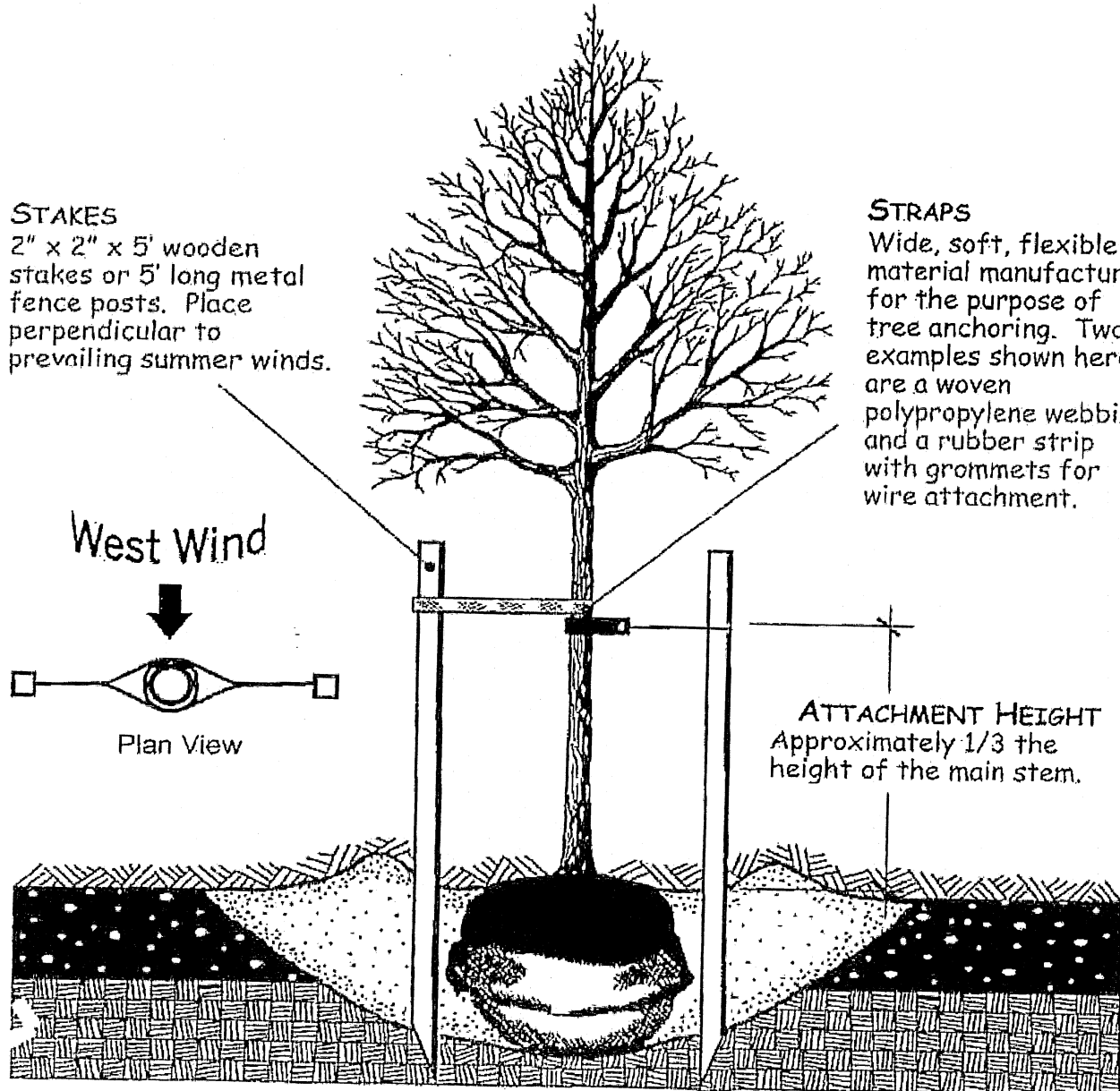

Use anchoring systems only where wind or soil conditions make it necessary. Remove after one year.



City of Opportunity. Moving Forward!

DETAIL 416-4 TREE ANCHORING - TYPE C TYPICAL SECTION

ATTACHMENT HEIGHT

Attach in a branch crotch approximately $\frac{1}{3}$ the height of the main stem, or at first available branch crotch above that point.

STAKES

2" x 2" wooden stakes or metal anchors. Cut stakes long enough for secure grip in subgrade. Angle stakes 20 - 30° off vertical. Use 3 stakes placed equal distance apart (120°). 4 stakes may be necessary for trees greater than 4" caliper.

STRAPS

Wide, soft, flexible material manufactured for the purpose of tree anchoring such as woven polypropylene webbing or rubber strips with grommets for wire attachment. Do not use hose and wire.

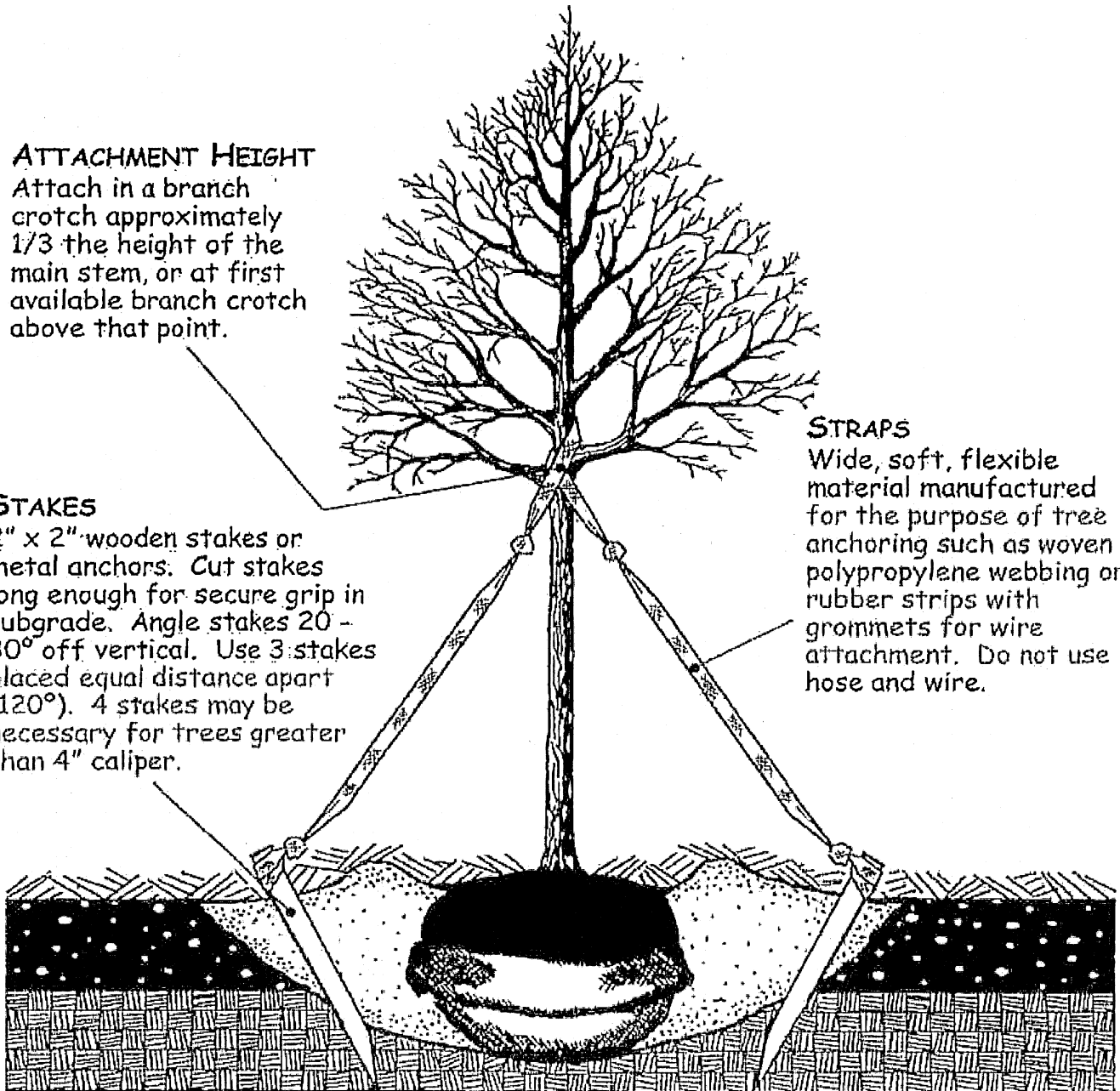

Use anchoring systems only where wind or soil conditions make it necessary. Remove after one year.



City of Opportunity. Moving Forward!

DETAIL 416-5 TREE ANCHORING - TYPE C TYPICAL SECTION

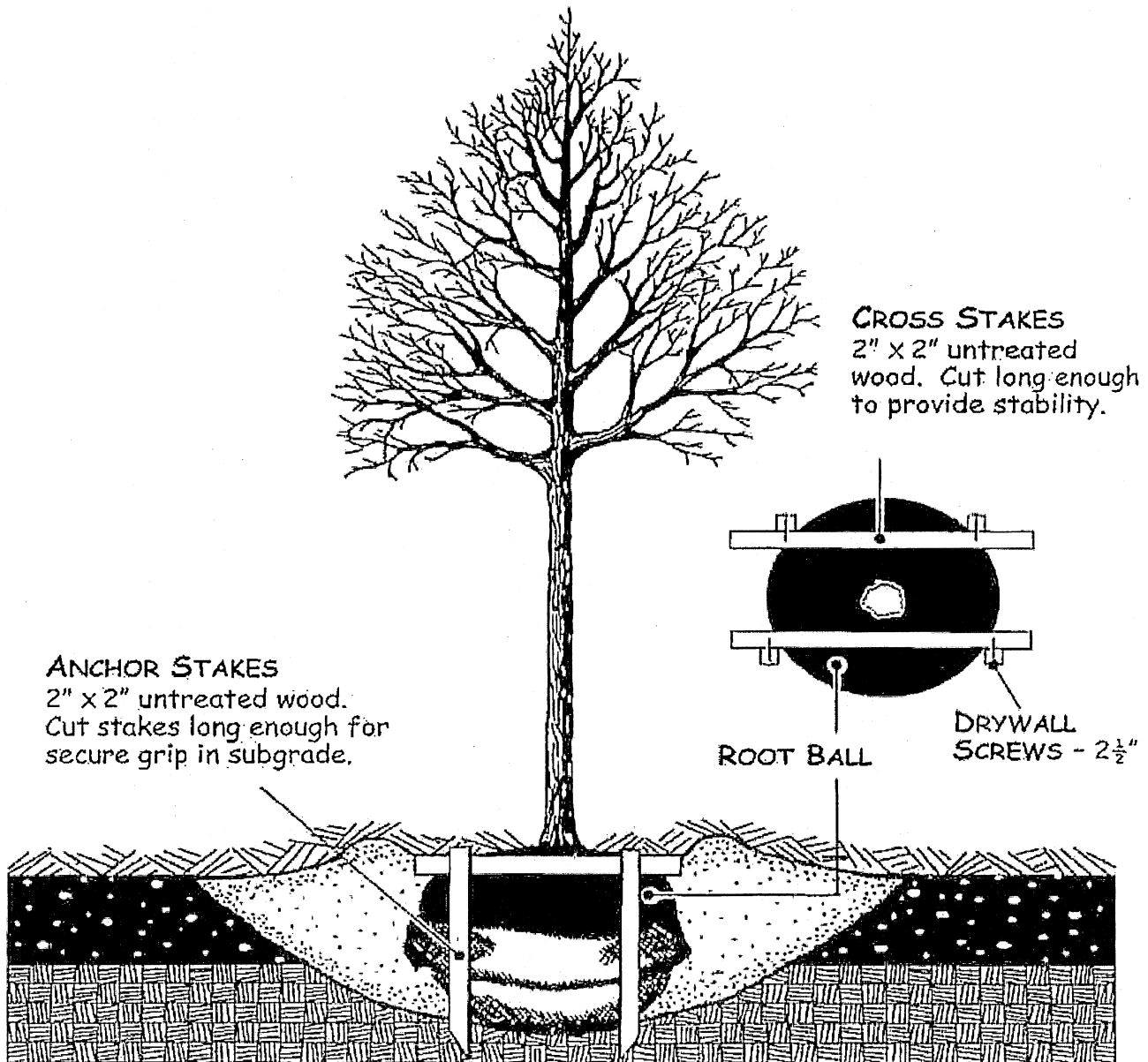

Use anchoring systems only where wind or soil
conditions make it necessary. Remove after one year.



City of Opportunity. Moving Forward!

DETAIL 416-6 TREE PLANTING IN PARKING LOTS TYPICAL SECTION

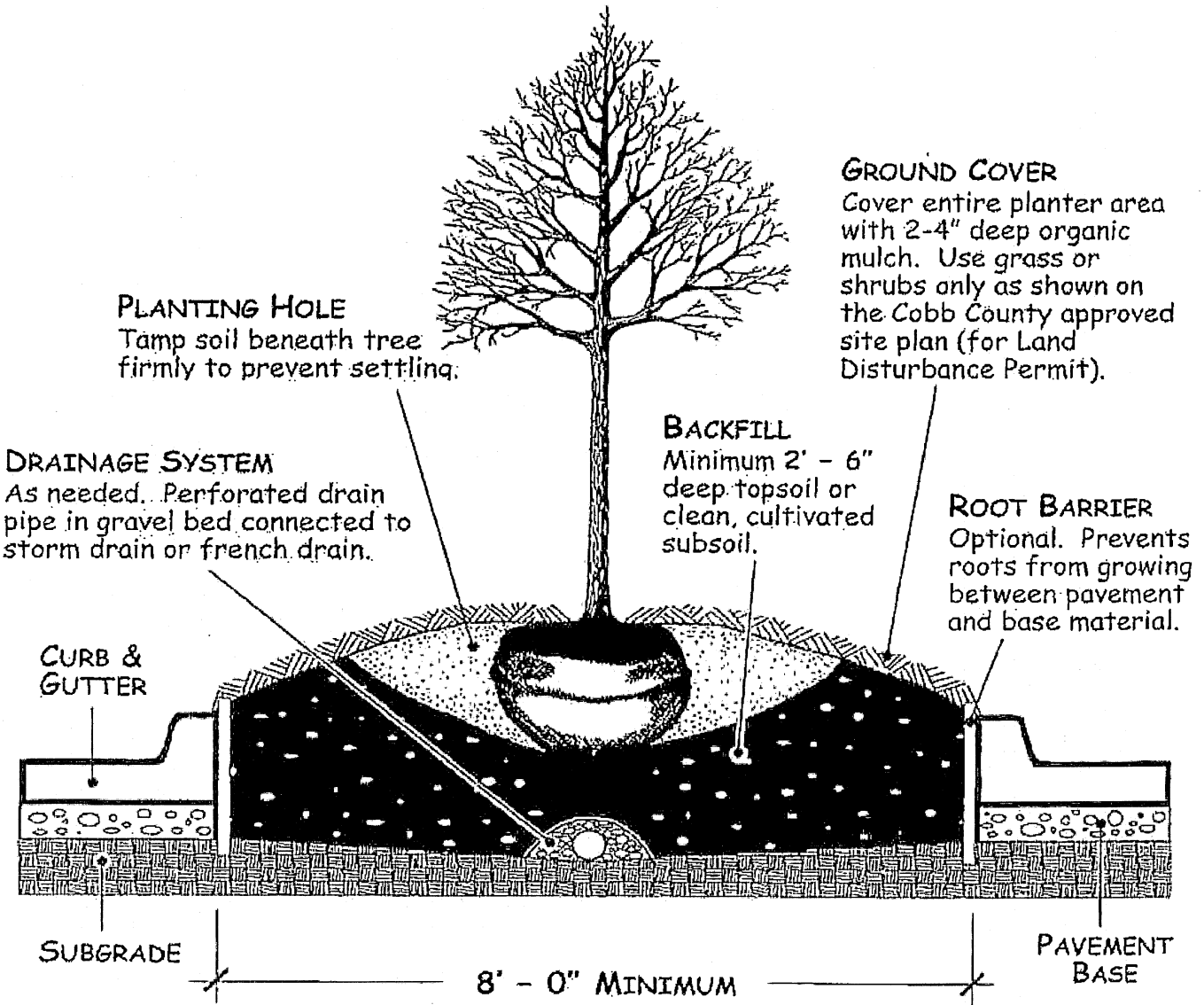



City of Opportunity. Moving Forward!

DETAIL 416-7 TREE PROTECTION FENCE TYPICAL SECTION

FENCE LOCATION

At limits of Critical Root Zone
(CRZ = 24 X trunk diameter)
or as shown on the Tree Protection Plan

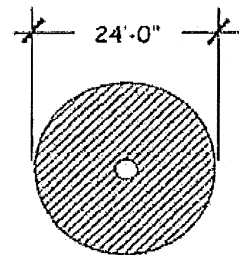
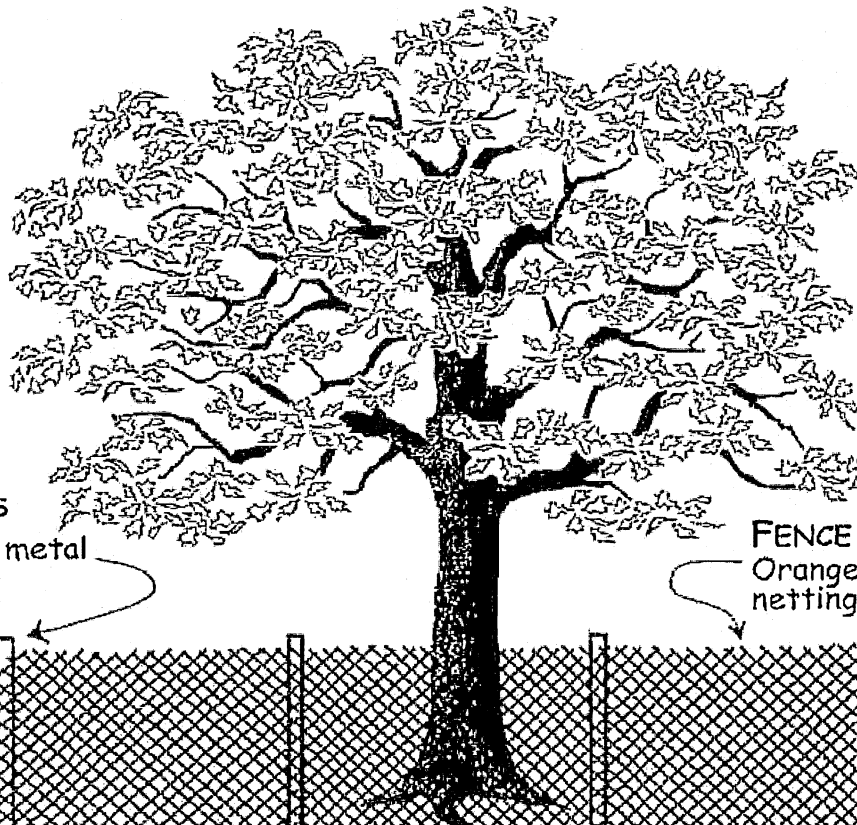

CRZ
1 ft. diameter tree

FENCE POSTS

2" x 2" oak or metal

FENCE MATERIAL

Orange laminated safety netting or equivalent

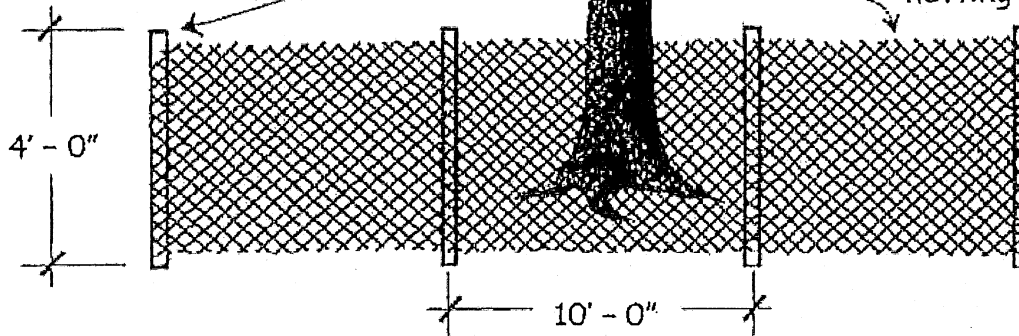

FOR ADDED PROTECTION

- Provide 4" deep wood chip mulch over any unprotected root zone.
- Make clean cuts on roots exposed by grading and backfill immediately.
- Provide temporary irrigation where practical and feasible.



City of Opportunity. Moving Forward!

DETAIL 1040A STANDARD DETAIL FOR MANHOLE COVER STORMWATER MANAGEMENT

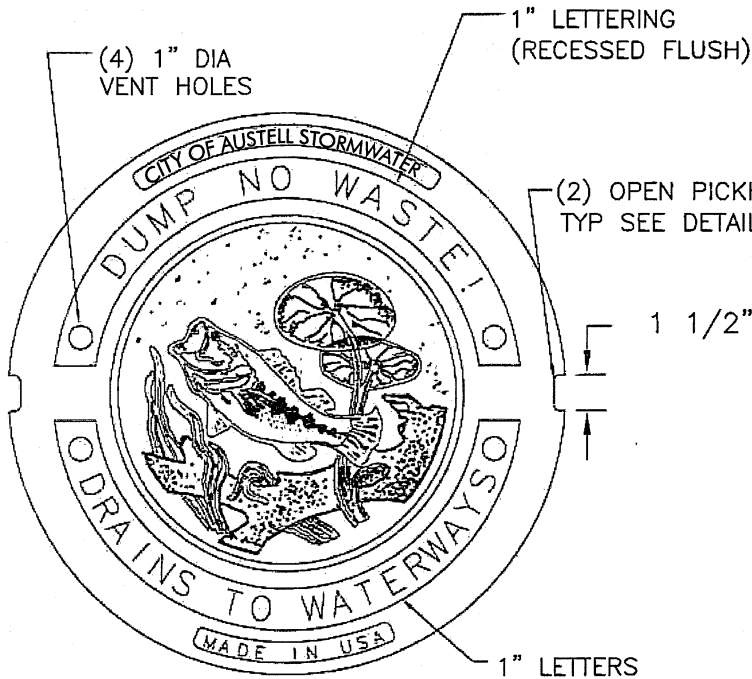

(2) OPEN PICKHOLES
TYP SEE DETAIL

1 1/2"

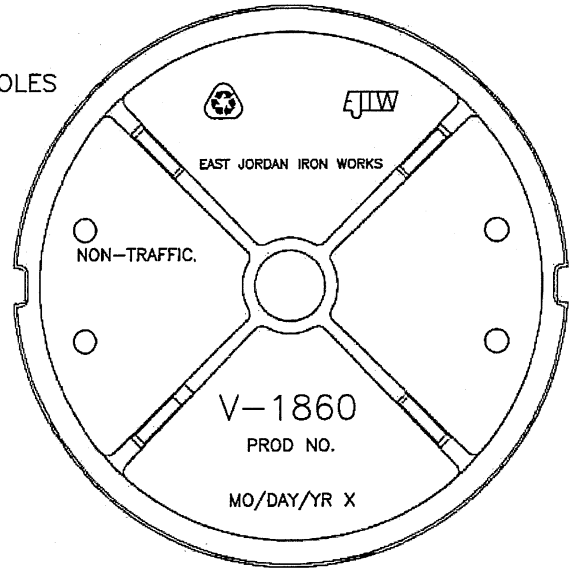

BOTTOM VIEW

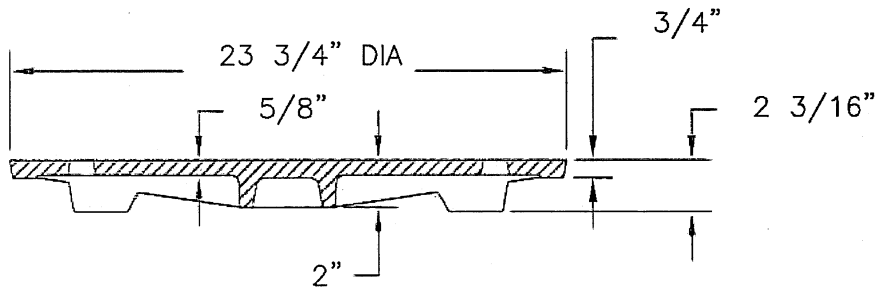

COVER SECTION

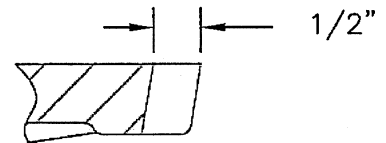

OPEN PICKHOLE DETAIL

OR EQUIVALENT



City of Opportunity. Moving Forward!

DETAIL 02270-1 SEDIMENT BARRIER (SILT FENCE)

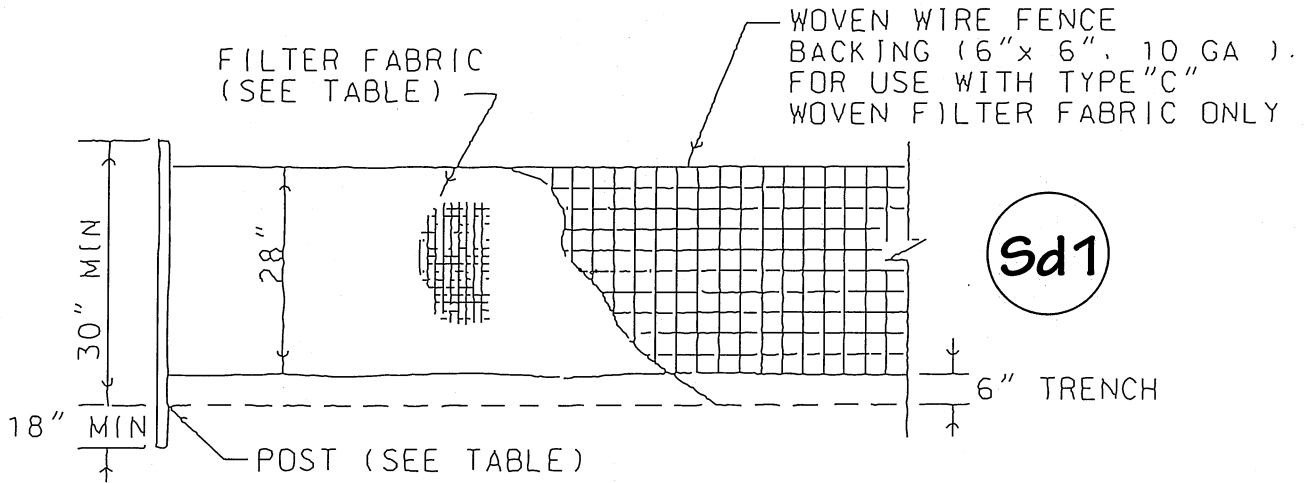

Sd1

FRONT VIEW

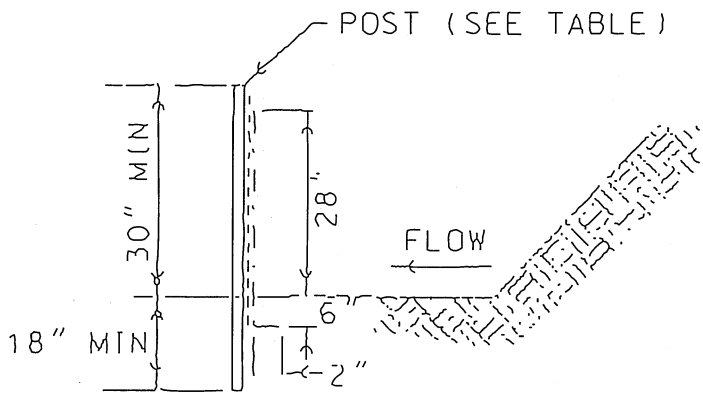

FILTER FABRIC TYPE	POST TYPE
A NON-WOVEN	3" DIA. OR 2x4 (SOFT WOOD) OR. 1 5"x1 5" (OAK) OR. 1 3 LB/FT (STEEL) 6' O.C.
C WOVEN	1 3 LB/FT (STEEL) 4' O.C. ONLY

SIDE VIEW

- NOTE: 1 SILT FENCING TO BE TYPE "A" OR TYPE "C"
AS NOTED ON EROSION CONTROL PLAN
- 2 FABRIC (TYPE "A" OR "C")
AS SPECIFIED IN GA D.O.T. LIST #36



City of Opportunity. Moving Forward!

DETAIL 02235-1 STEEL CASING

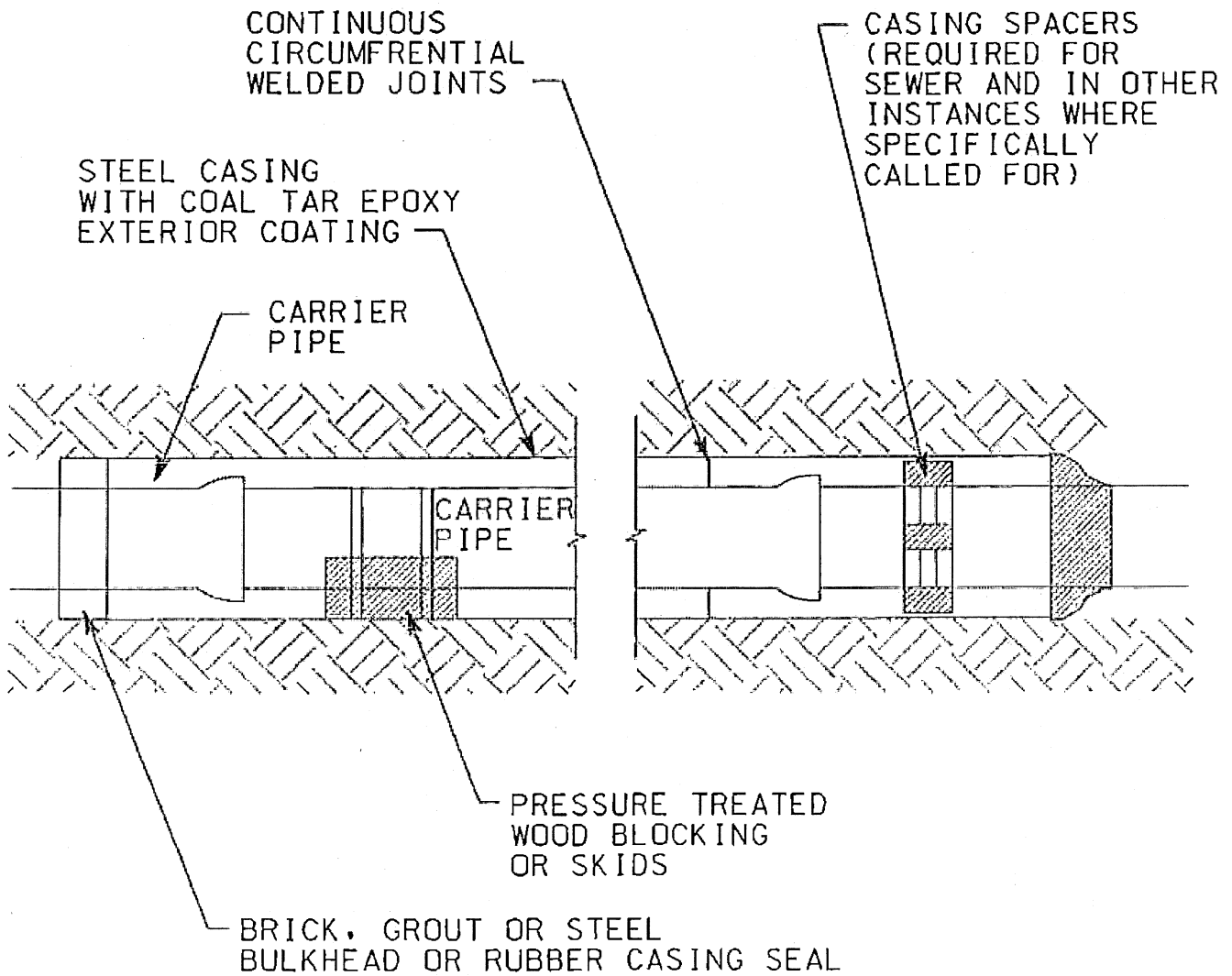



City of Opportunity. Moving Forward!

DETAIL 02270-2 SEDIMENT BARRIER (STAKED HAY BALE)

ANGLE FIRST STAKE TOWARDS
PREVIOUSLY LAID BALE

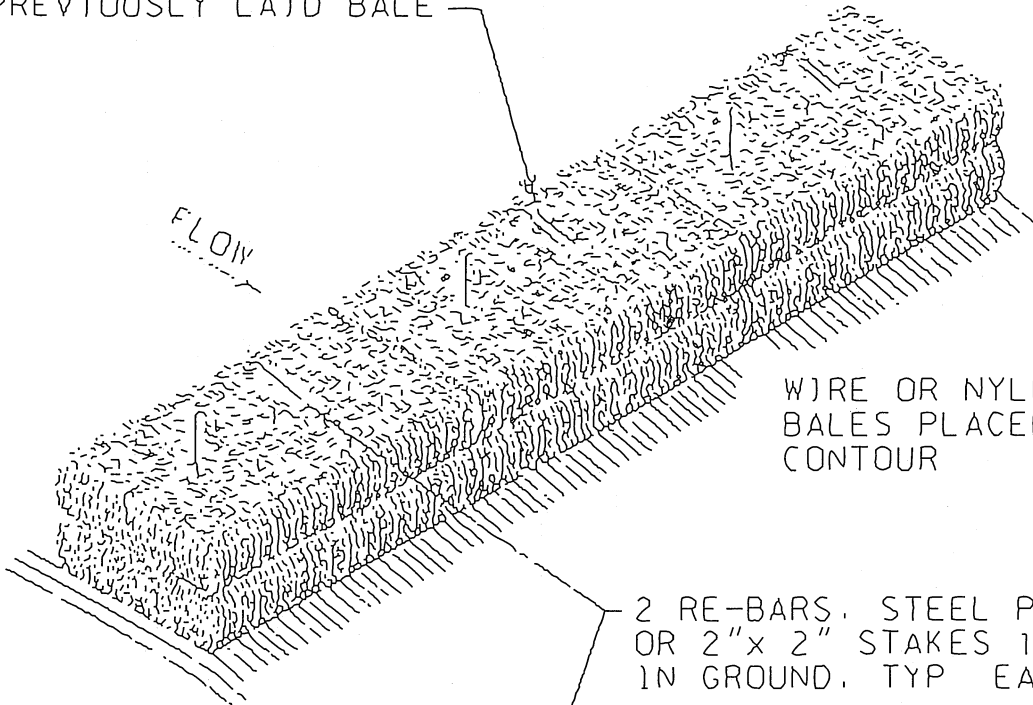

WIRE OR NYLON BOUND
BALES PLACED ON THE
CONTOUR

2 RE-BARS, STEEL PICKETS,
OR 2" x 2" STAKES 1 1/2' TO 2'
IN GROUND, TYP EACH BALE

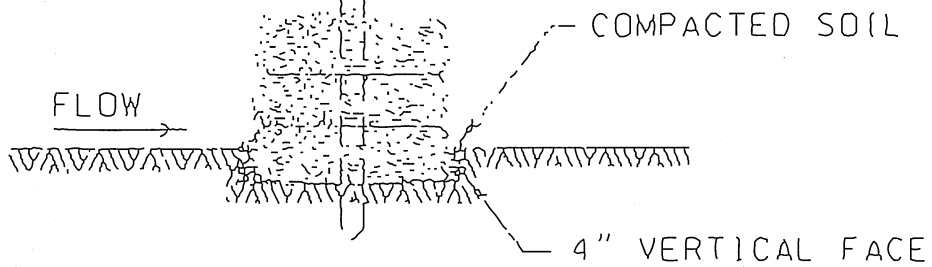



DETAIL 02270-3 INLET SEDIMENT TRAP

City of Opportunity. Moving Forward!

Sd2

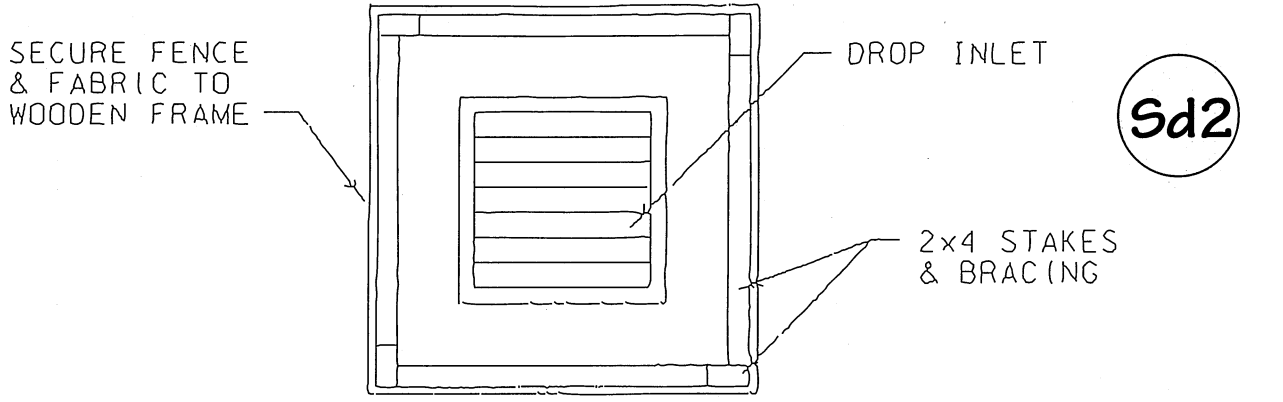

2x4 STAKES & BRACING

PLAN

WOVEN WIRE FENCE BACKING (12" x 12", 10 GA)

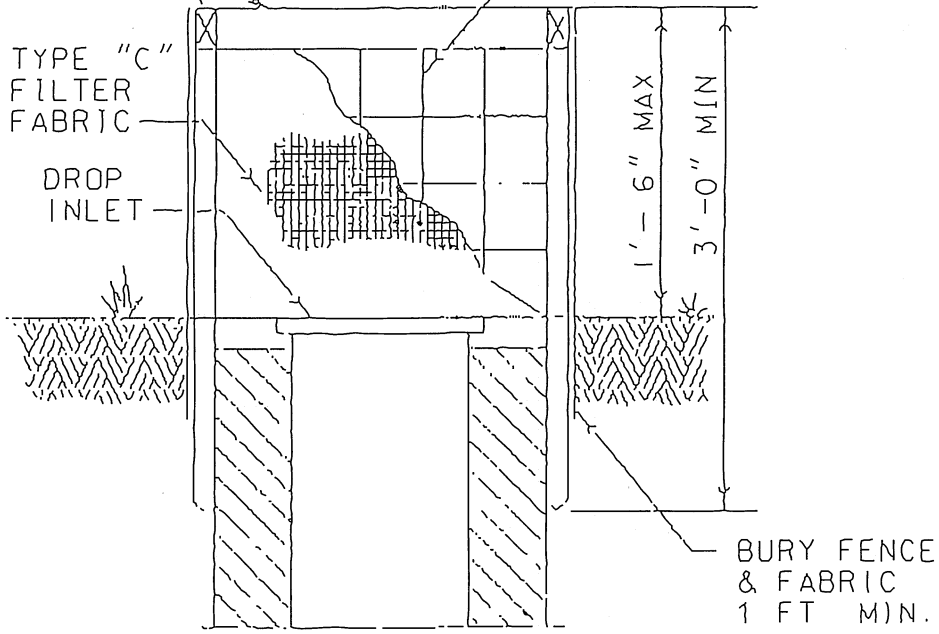

TYPE "C" FILTER FABRIC

DROP INLET

1' - 6" MAX

3' - 0" MIN

BURY FENCE & FABRIC 1 FT MIN.

SECTION



City of Opportunity. Moving Forward!

DETAIL 02270-4A CURB INLET FILTER TRAP (CATCH BASIN - IN LINE)

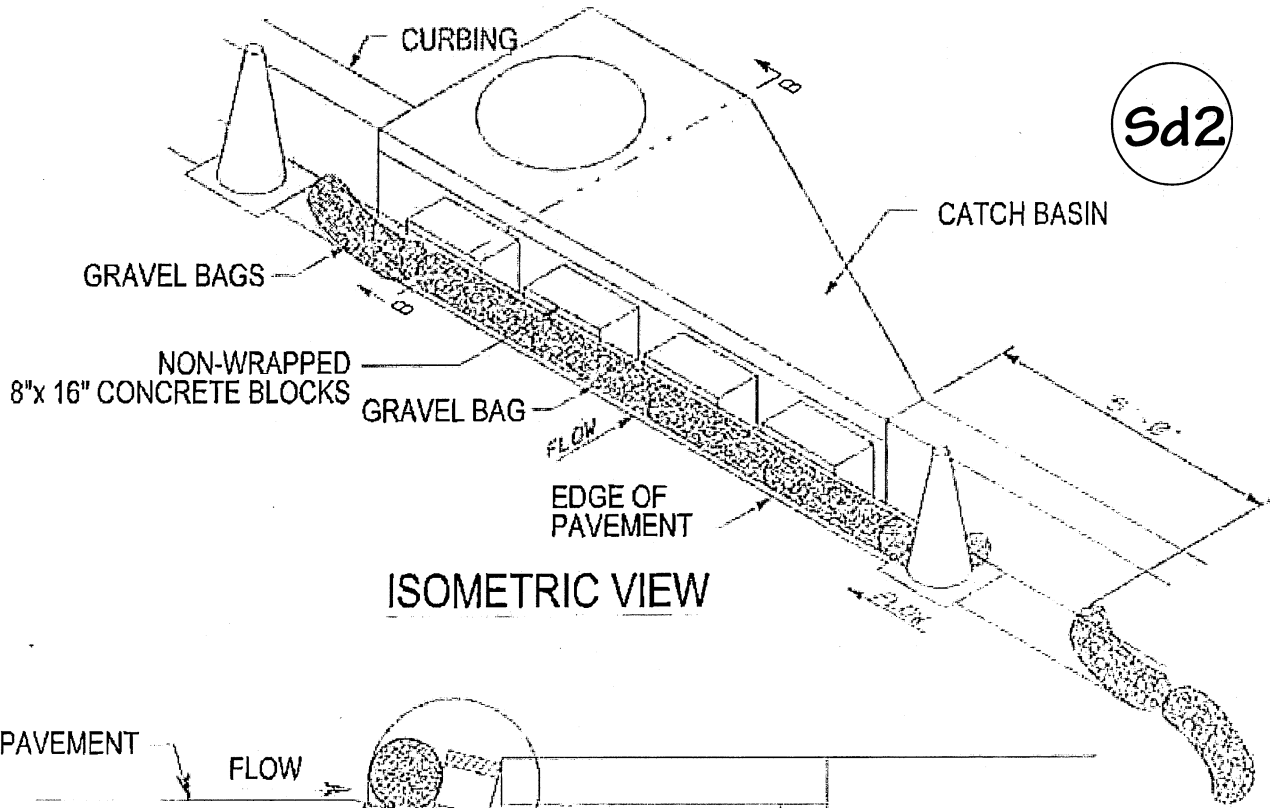

ISOMETRIC VIEW

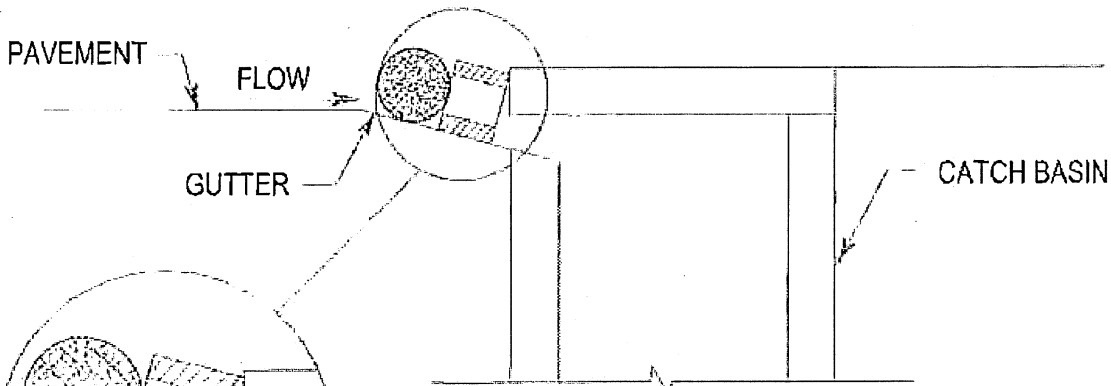

SECTION BB

NOTE: CURB INLET FILTER SHALL BE INSPECTED AND MAINTAINED AFTER EVERY RAIN EVENT OR AS DIRECTED



City of Opportunity. Moving Forward!

DETAIL 02270-4B CURB INLET FILTER TRAP (CATCH BASIN - IN SAG)

Sd2

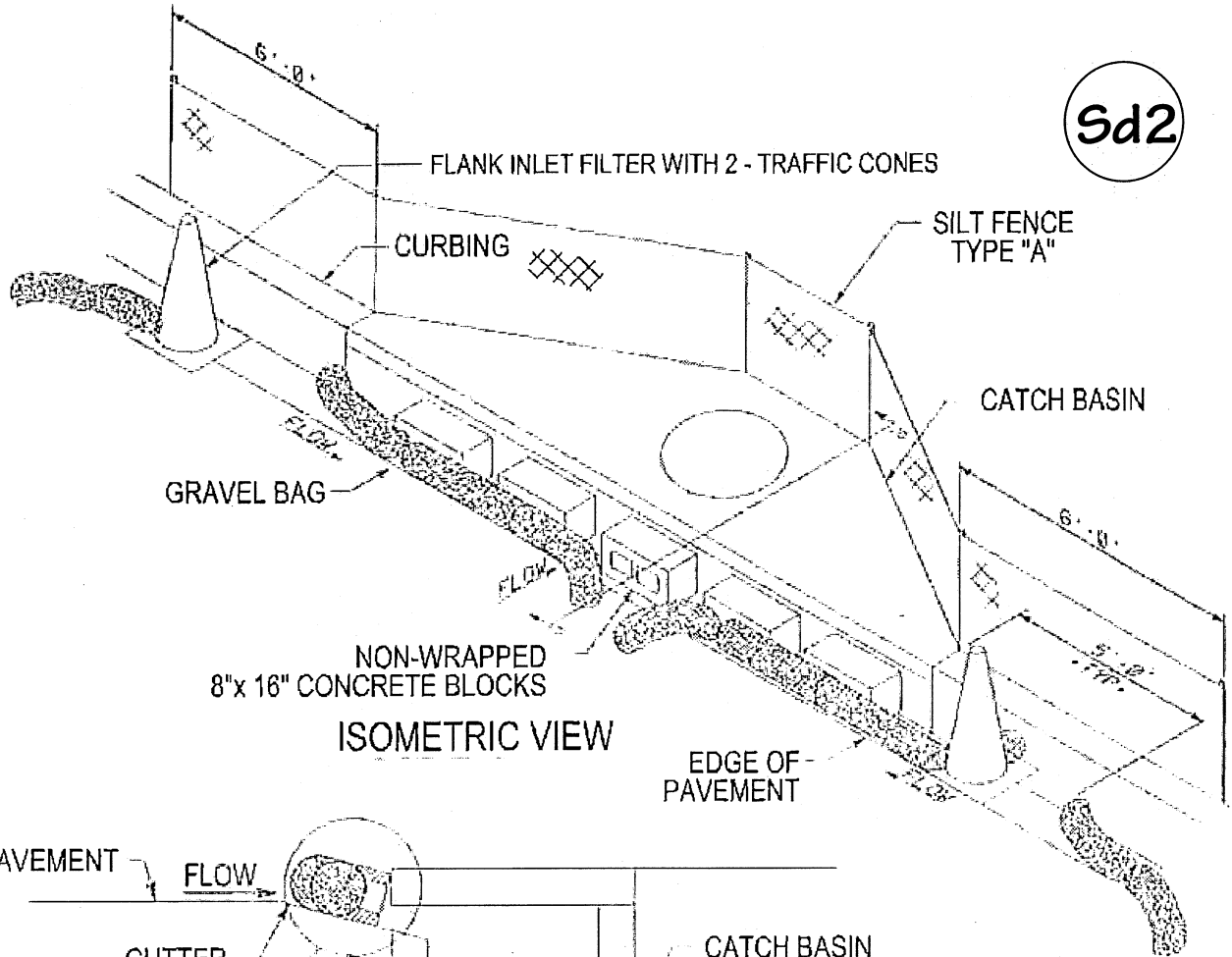

Sd2 SECTION BB

NOTE: CURB INLET FILTER SHALL BE INSPECTED AND MAINTAINED AFTER EVERY RAIN EVENT OR AS DIRECTED



City of Opportunity. Moving Forward!

DETAIL 02270-5 CHECK DAM

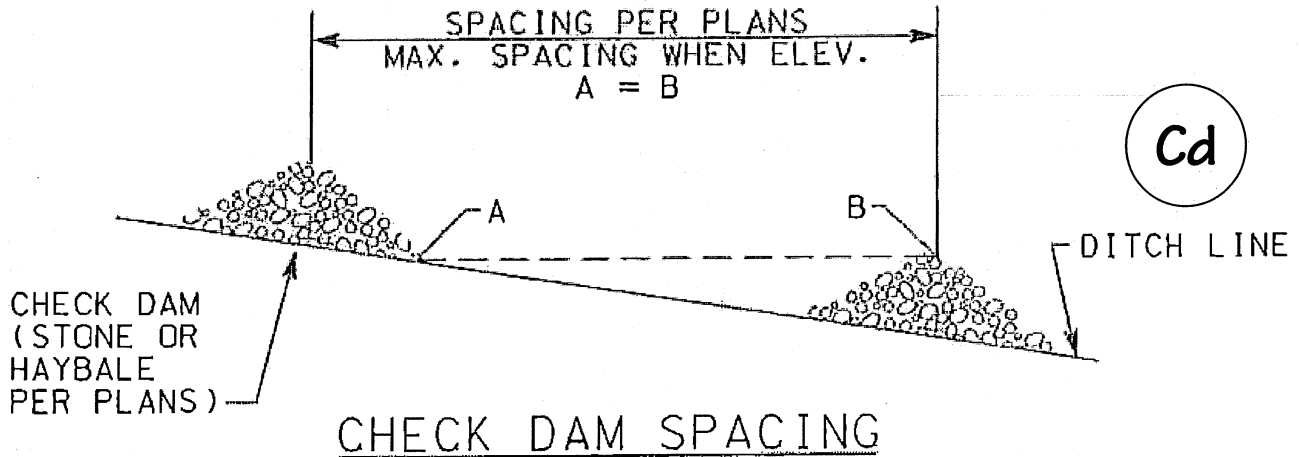

STONE CHECK DAM

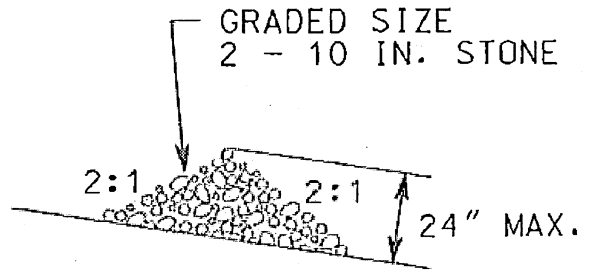
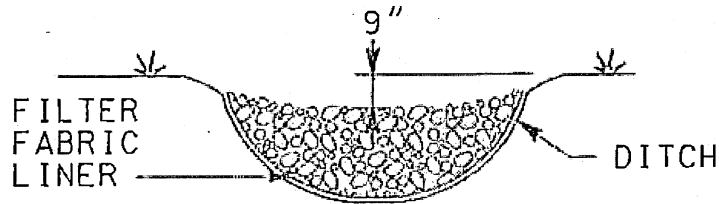

STONE

STAKED HAY BALES (SEE Sd 1)

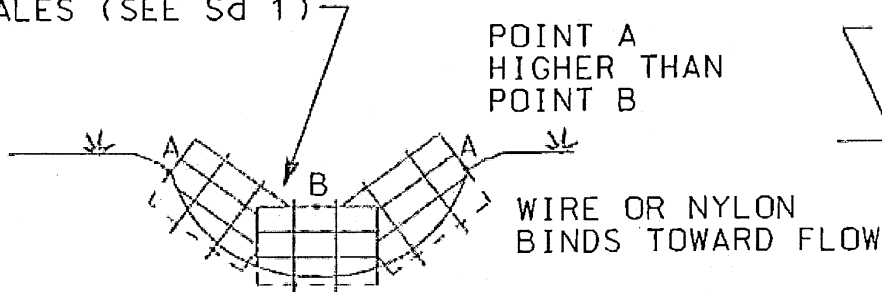

ELEVATION

HAYBALE

HAY BALES
(NUMBER VARIES
TO SUIT CONDITIONS)

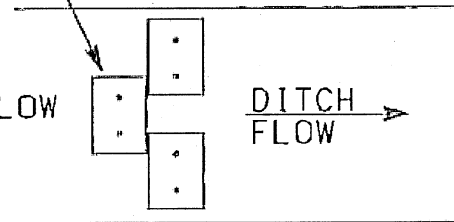

PLAN



City of Opportunity. Moving Forward!

DETAIL 02270-6 (A) CHANNEL STABILIZATION (GABION)

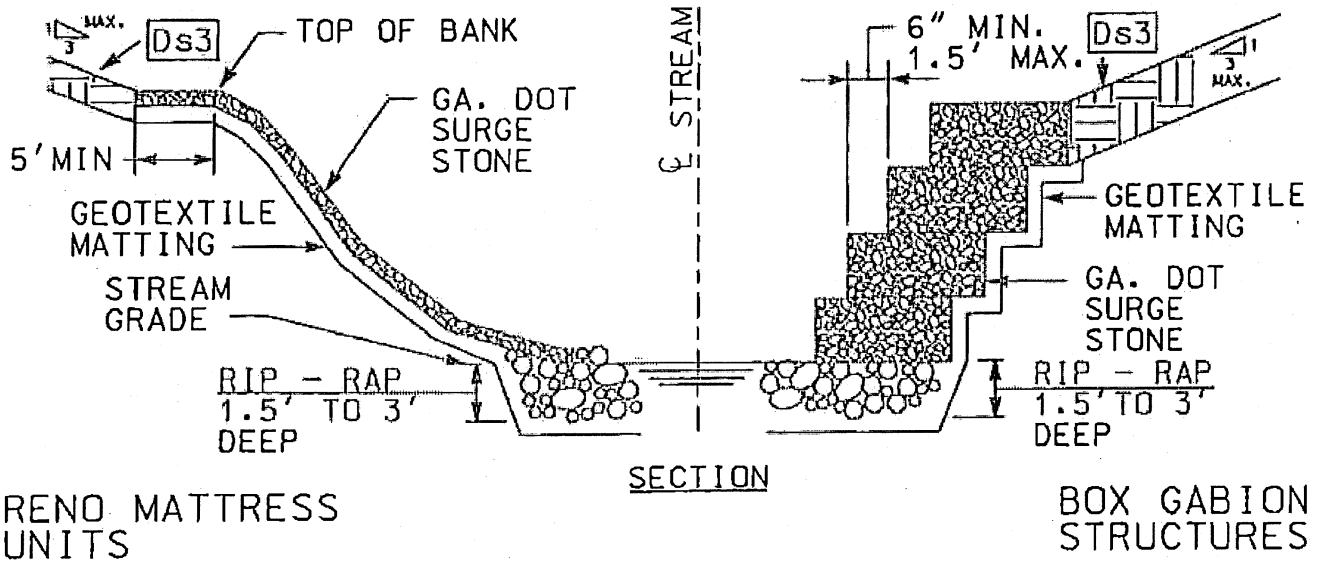

NOTES:

- CLEARING AND EXCAVATION OF STREAM BED AND BANKS SHALL BE KEPT TO A MINIMUM. ALL DISTURBED AREAS SHALL BE STABILIZED.
- THE WIRE MESH OR WELDED WIRE FORMING RENO MATTRESS OR BOX GABION SHALL BE MACAFRRI OR EQUAL, WITH A GREY PVC (POLYVINYL CHLORIDE) COATING.
- GEOTEXTILE MATTING SHALL BE TREVIRA SPUNBOUND 1125 FILTER FABRIC OR EQUAL.
- THE LOWER LIMITS OF THE RENO MATTRESS OR BOX GABION SHALL BE FIELD STAKED AND APPROVED BY AUSTELL PUBLIC WORKS.
- SIZE OF RIP RIP RAP USE AS FOUNDATION FOR RENO MATTRESS AND BOX GABIONS SHALL BE DETERMINED BY AUSTELL PUBLIC WORKS.



City of Opportunity. Moving Forward!

DETAIL 02270-6 (B) CHANNEL STABILIZATION (RIP RAP)

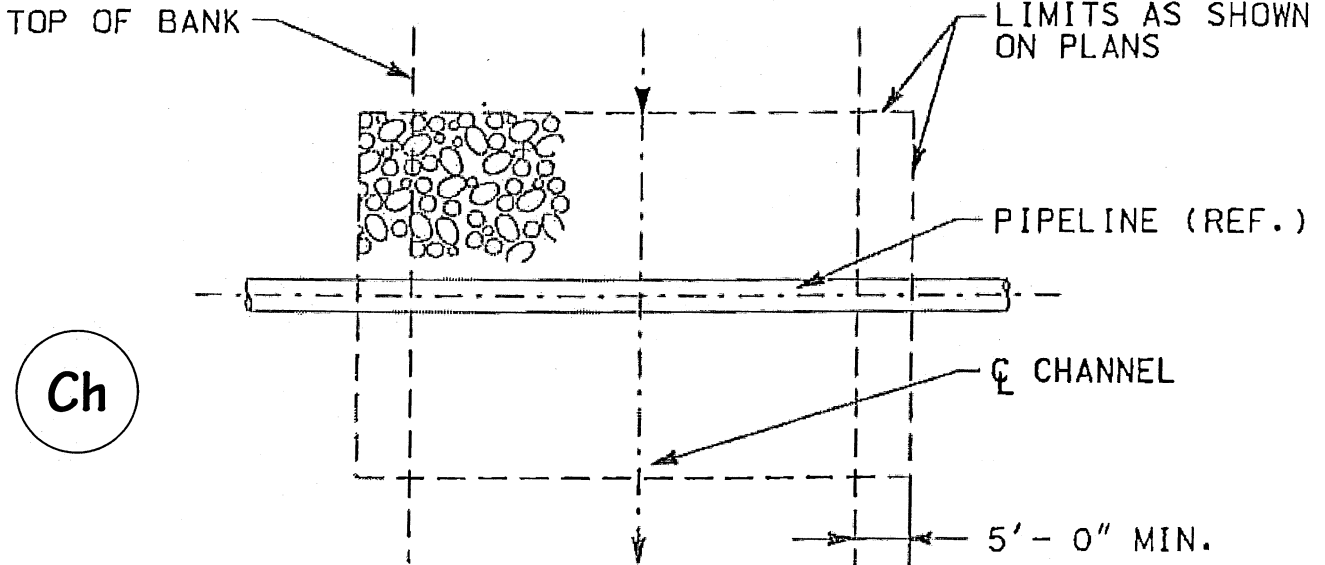

6" LAYER FILTER
BEDDING STONE AND/OR
GEOTEXTILE MATTING
(TREVIRA SPUNBOUND
1125 FILTER FABRIC
OR EQUAL)

MIN. THICKNESS:
TYPE 1 - 24"
TYPE 3 - 12"





City of Opportunity. Moving Forward!

DETAIL 02270-10 (A) TEMPORARY STREAM CROSSING

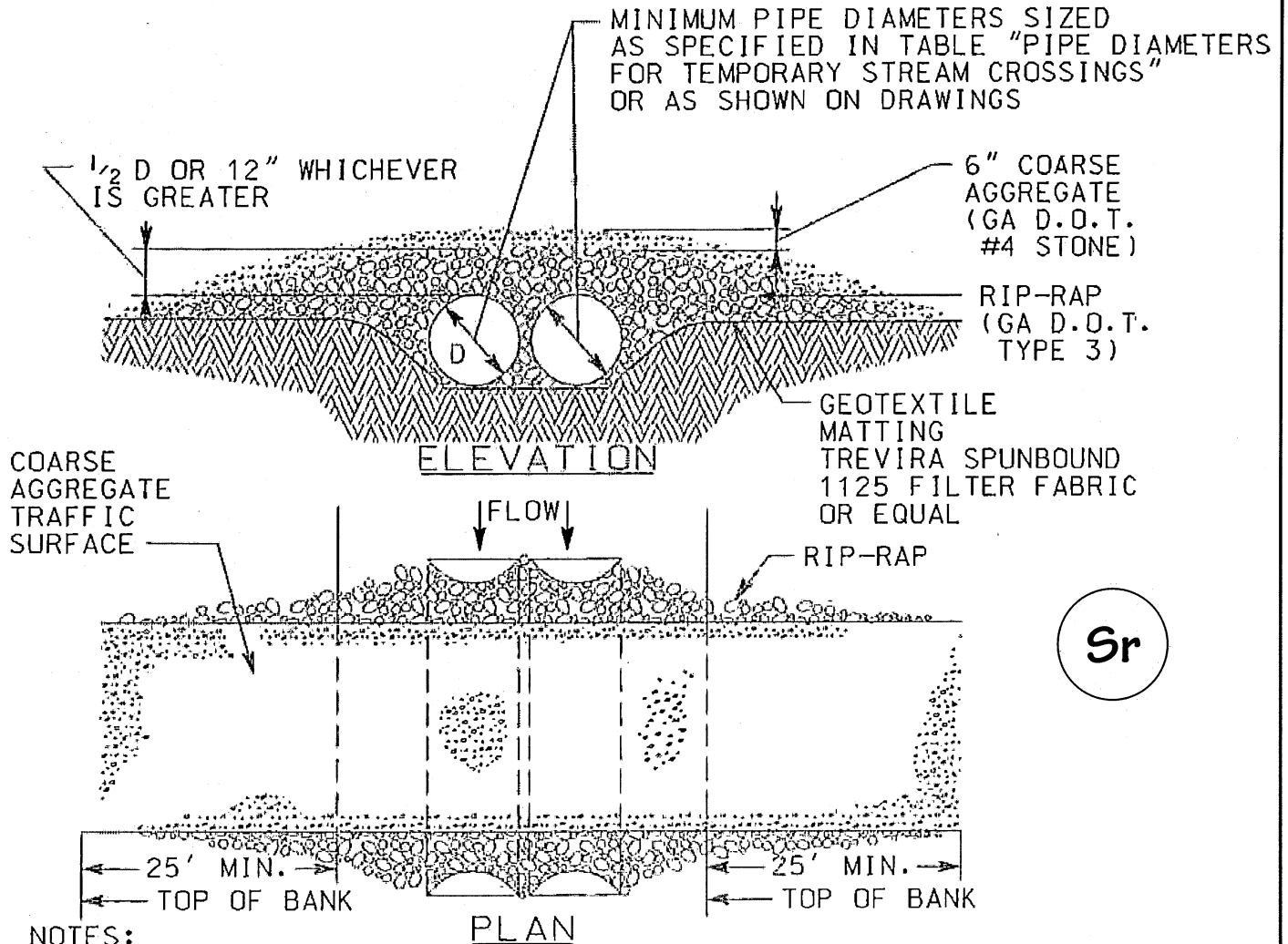

Sr

NOTES:

1. CLEARING AND EXCAVATION OF STREAM BED AND BANKS SHALL BE KEPT TO A MINIMUM.
2. REMOVE STRUCTURE AS SOON AS IT IS NO LONGER NEEDED FOR CONSTRUCTION OF PIPE AND ENCASEMENT
3. RESHAPE STREAM TO ORIGINAL CROSS SECTION AND STABILIZE AS SHOWN ON CHANNEL STABILIZATION DETAIL.



City of Opportunity. Moving Forward!

DETAIL 02270-10 (B) TEMPORARY STREAM CROSSING

CORRUGATED METAL PIPE (CMP) DIAMETERS FOR TEMPORARY STREAM CROSSINGS

DRAINAGE AREA (ACRES)	AVERAGE SLOPE OF WATERSHED			
	1%	4%	8%	16%
1 - 25	24	24	30	30
26 - 50	24	30	36	36
51 - 100	30	36	42	48
101 - 150	30	42	48	54
151 - 200	36	42	48	54
201 - 250	36	48	54	54
251 - 300	36	48	54	60
351 - 400	42	54	60	60
401 - 450	42	54	60	72
451 - 500	42	54	60	72
501 - 550	48	60	60	72
551 - 600	48	60	60	72
601 - 640	48	60	72	72

ASSUMPTIONS FOR DETERMINING THE TABLE: USDA-NRCS PEAK DISCHARGE METHOD; CN=65; RAINFALL DEPTH (AVERAGE FOR GEORGIA) = 3.7" FOR TWO YEAR FREQUENCY. PIPE DIAMETERS SHOWN IN THE TABLE ARE IN INCHES.



City of Opportunity. Moving Forward!

DETAIL 02270-11 DIVERSION (PIPED)

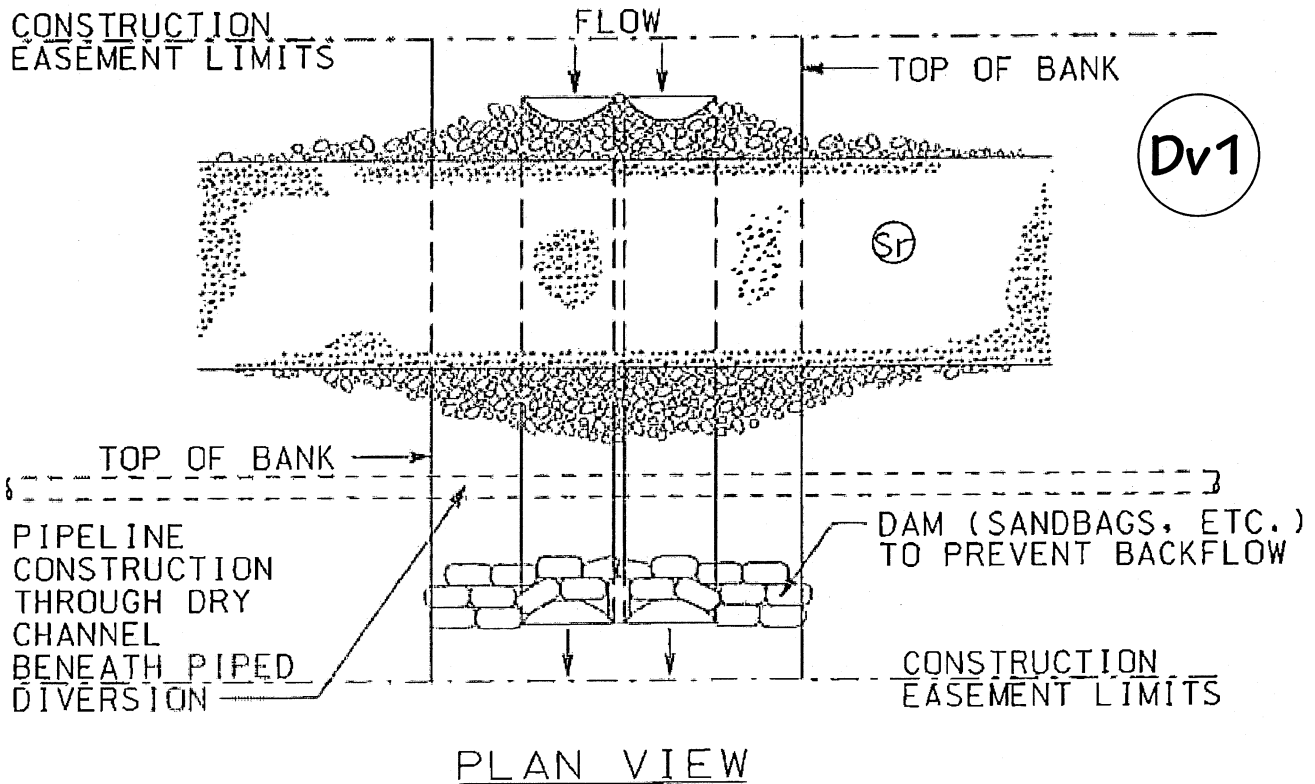

NOTES:

1. CLEARING AND EXCAVATION OF STREAM BED AND BANKS SHALL BE KEPT TO A MINIMUM.
2. REMOVE STRUCTURE AS SOON AS IT IS NO LONGER NEEDED FOR CONSTRUCTION OF PIPE AND ENCASEMENT
3. RESHAPE STREAM TO ORIGINAL CROSS SECTION AND STABILIZE AS SHOWN ON CHANNEL STABILIZATION DETAIL.



City of Opportunity. Moving Forward!

DETAIL 02270-12 DIVERSION (PUMPED)

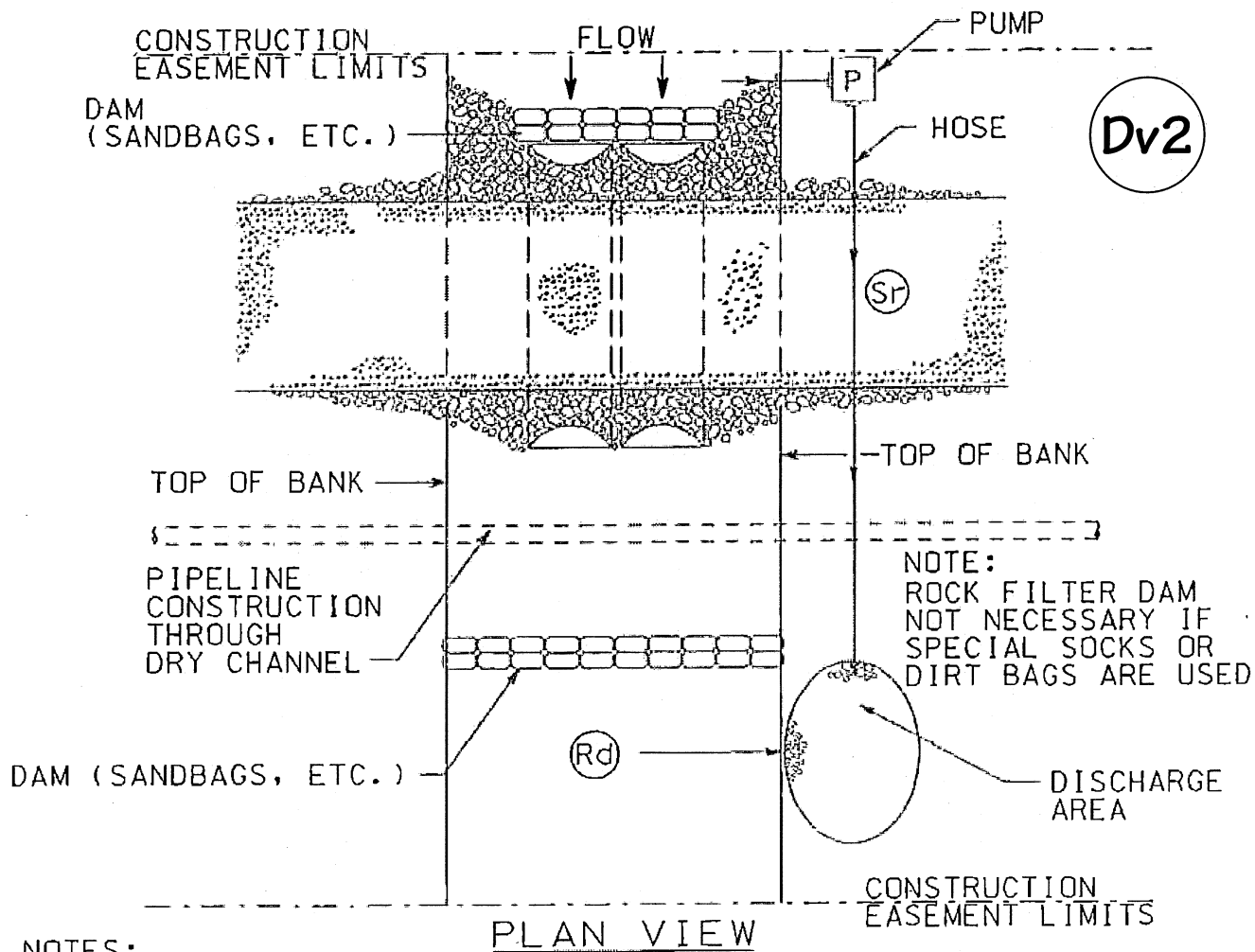

NOTES:

1. CLEARING AND EXCAVATION OF STREAM BED AND BANKS SHALL BE KEPT TO A MINIMUM.
2. REMOVE STRUCTURE AS SOON AS IT IS NO LONGER NEEDED FOR CONSTRUCTION OF PIPE AND ENCASEMENT
3. RESHAPE STREAM TO ORIGINAL CROSS SECTION AND STABILIZE AS SHOWN ON CHANNEL STABILIZATION DETAIL.



City of Opportunity. Moving Forward!

DETAIL 02270-13(A) ENGINEERED DIVERSION STRUCTURE (SEQUENCE ONE)

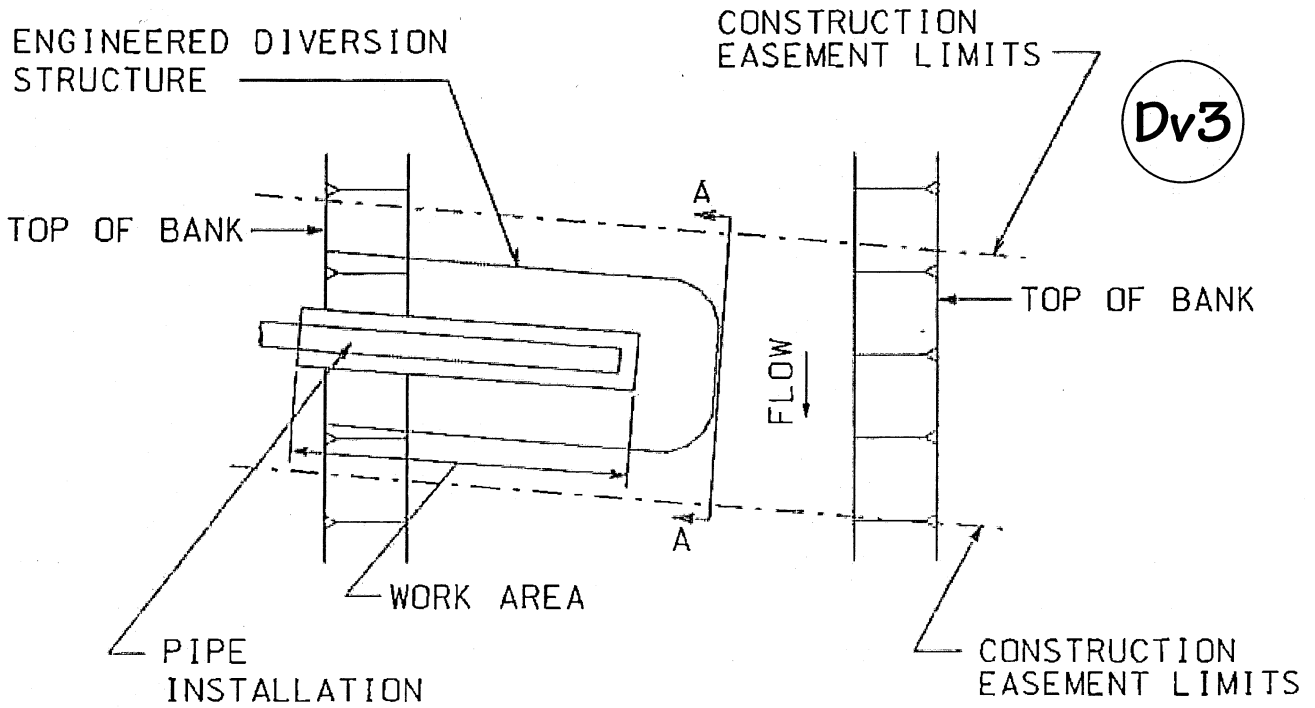



City of Opportunity. Moving Forward!

DETAIL 02270-13(B) ENGINEERED DIVERSION STRUCTURE (SEQUENCE TWO)

Dv3

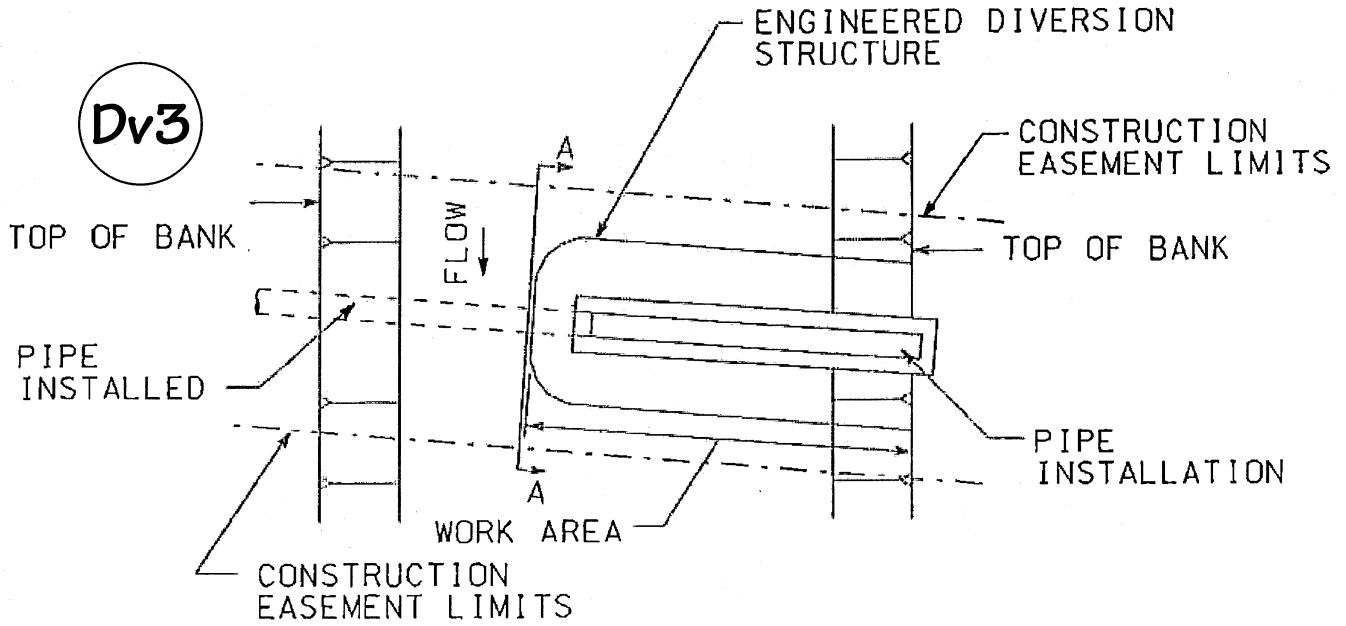



City of Opportunity. Moving Forward!

DETAIL 02270-13(AA) ENGINEERED DIVERSION STRUCTURE (SEQUENCE AA)

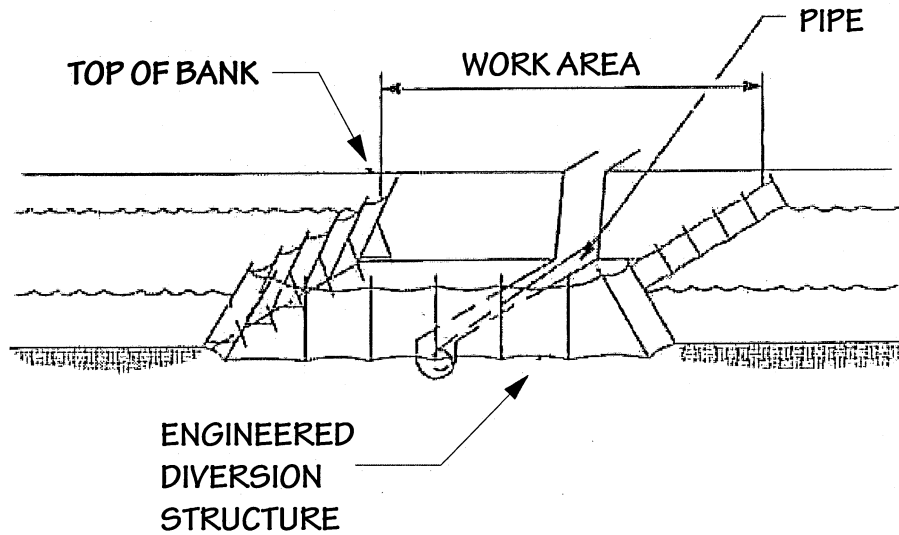

Dv3

NOTES:

- CLEARING AND EXCAVATION OF STREAM BED AND BANKS SHALL BE KEPT TO A MINIMUM.
- REMOVE STRUCTURE AS SOON AS IT NO LONGER NEEDED FOR CONSTRUCTION OF PIPE AND EASEMENT.
- RESHAPE STREAM TO ORIGINAL CROSS SECTION AND STABILIZE AS SHOWN ON CHANNEL STABILIZATION DETAIL.



City of Opportunity. Moving Forward!

DETAIL 02270-15 ROCK FILTER DAM

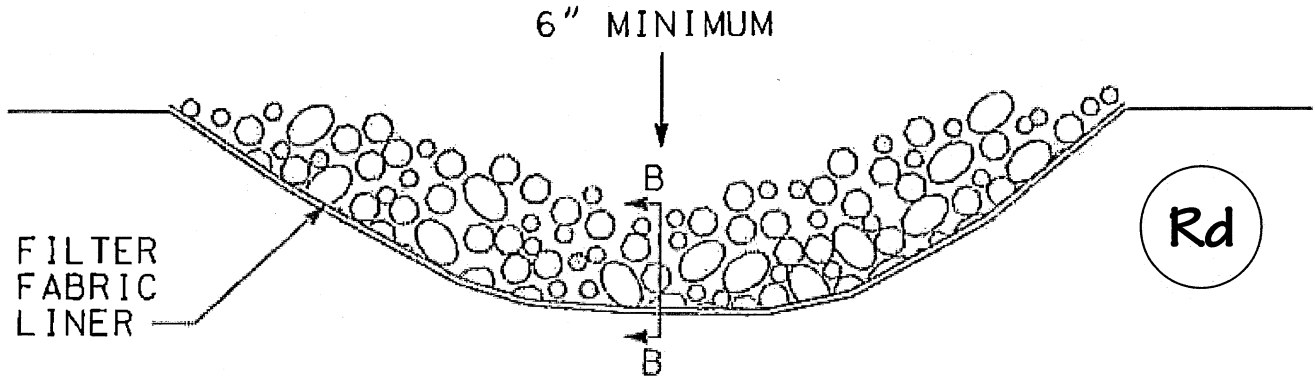

ELEVATION

NOTE: SEDIMENT TO BE CLEANED OUT
WHEN VOLUME BECOMES HALF FULL

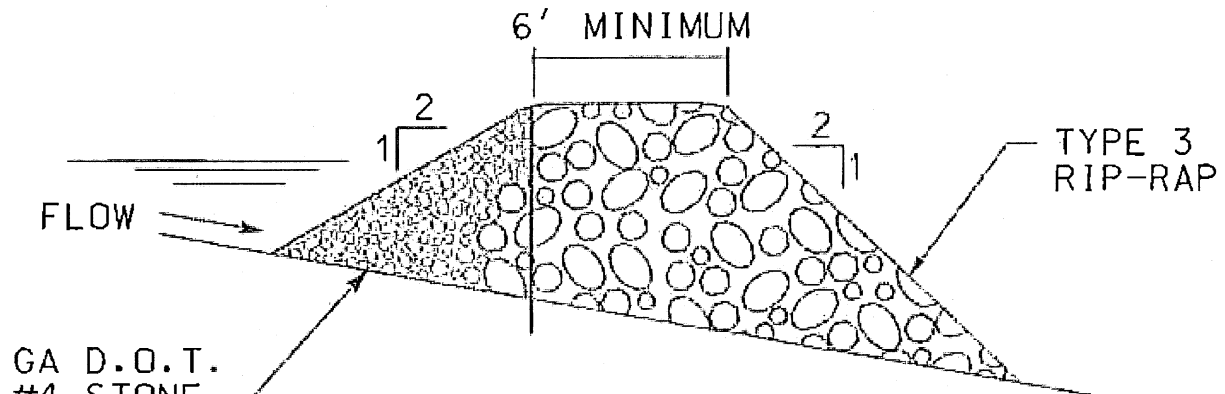

SECTION BB

NOTE:
THIS STRUCTURE SHALL NOT BE INSTALLED IN A LIVE STREAM.



City of Opportunity. Moving Forward!

DETAIL 02270-16 CONSTRUCTION EXIT

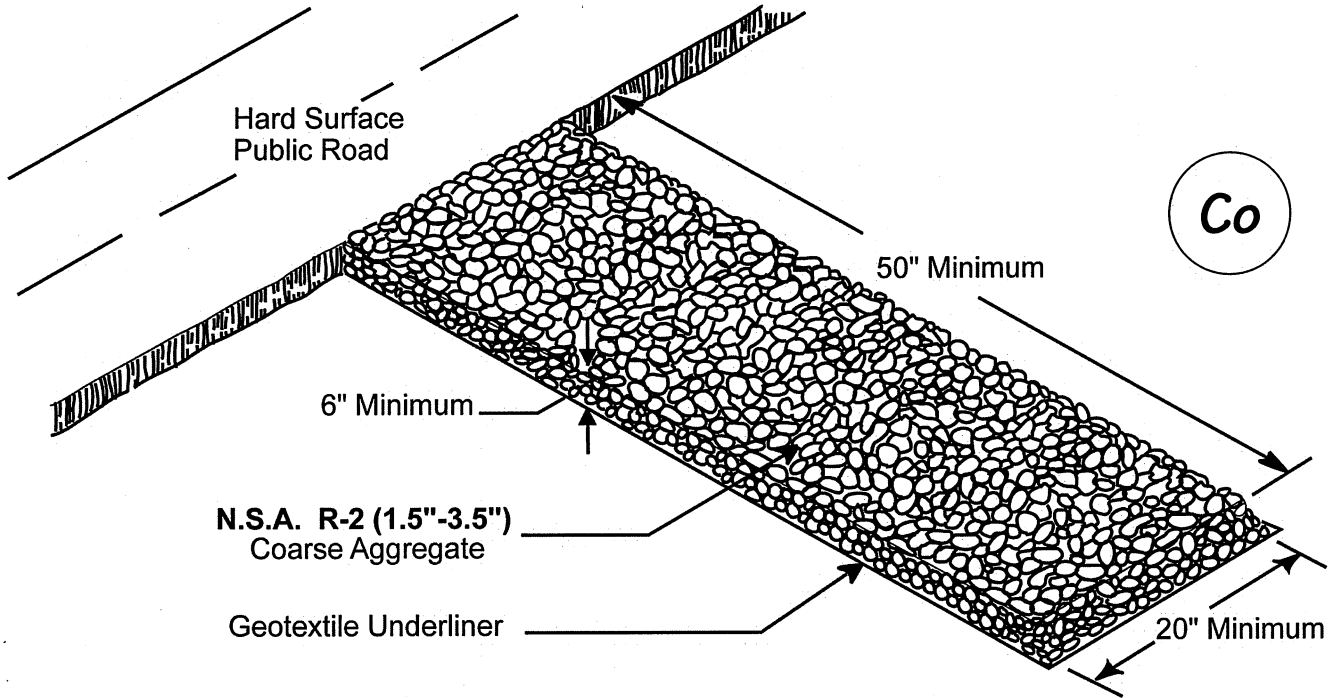



City of Opportunity. Moving Forward!

DETAIL 02270-20(A)
DISTURBED AREA STABILIZATION
(WITH MULCHING)

Ds1

ESTABLISHING A TEMPORARY PROTECTION FOR
DISTURBED AREAS USING SPECIFIC MULCH MATERIALS.

1. MULCH MATERIALS SHALL CONSIST OF DRY STRAW OR HAY AT 2.5 TONS PER ACRE. EROSION CONTROL MATTING OR NETTING OR POLYETHYLENE FILM.
2. THIS STANDARD APPLIES TO GRADES OR CLEARED AREAS WHICH MAY BE SUBJECTED TO EROSION CONTROL FOR SIX MONTHS OR LESS AND CAN BE STABILIZED WITH A MULCH COVER.

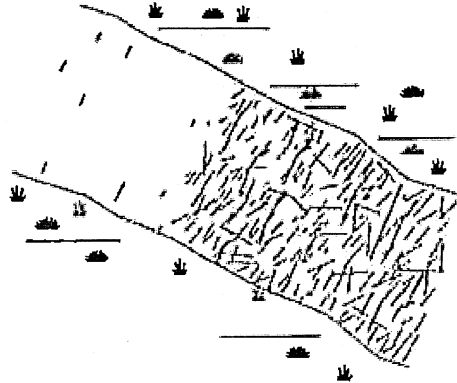



City of Opportunity. Moving Forward!

DETAIL 02270-20(B)
DISTURBED AREA STABILIZATION
(WITH TEMPORARY SEEDING)

Ds2

ESTABLISHING A TEMPORARY VEGETATIVE COVER WITH FAST GROWING SEEDINGS.

1. < 12 MONTHS OR UNTIL ESTABLISHMENT OF FINISHED GRADE OR PERMANENT VEGETATION.
2. SITE PREPARATION:
 - GRADING AND SHAPING
 - SEEDBED PREPARATION
 - APPLY LIME AND FERTILIZER
 - PLANT SEEDING, SELECT SPECIES BY SEASON AND REGION
 - APPLY MULCHING MATERIAL AS NEEDED (SEE Ds1 FOR TYPES AND RATES)
 - IRRIGATE IF NEEDED BUT NOT @ RATE TO CAUSE EROSION
3. SEE DETAIL 02270-21 FOR PLANTING DATES

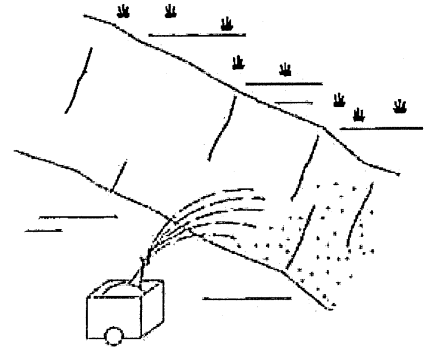

NOTE: CONTRACTOR SHALL STABILIZE ALL AREAS WITH TEMPORARY VEGETATION THAT ARE TO BE EXPOSED WITHOUT STORM WATER PROTECTION FOR LONGER THAN 7 DAYS.



City of Opportunity. Moving Forward!

DETAIL 02270-20(C) DISTURBED AREA STABILIZATION (WITH PERMANENT VEGETATION)

Ds3

ESTABLISHING A PERMANENT VEGETATIVE COVER ON A DISTURBED AREA.

1. APPLICABLE ON HIGHLY ERODIBLE OR SEVERELY ERODED AREAS, SOMETIMES CALLED "CRITICAL AREAS" INCLUDING:

- CHANNEL BANKS
- SPOIL AREAS
- GULLIED LANDS
- ROADSIDES
- BERMS

2. GRADING AND SHAPING REQ'D. WHERE FEASIBLE AND PRACTICAL.
3. FESCUE ON SLOPES STEEPER THAN 3 TO 1 SHALL BE HYDROSEEDDED OR REPLACED AS SOD.
4. MULCH ALL SLOPES STEEPER THAN 3% AND IN BOTTOM OF SPILLWAYS AND ON ROADBANKS (SEE Ds1 FOR TYPES AND RATES).
5. ANCHOR MULCH IMMEDIATELY.

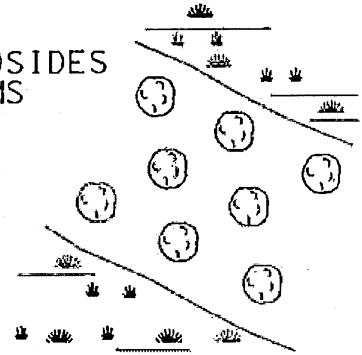



City of Opportunity. Moving Forward!

DETAIL 02270-20(D) DISTURBED AREA STABILIZATION (WITH SODDING)

Ds4

FERTILIZER APPLICATION TABLE

FERTILIZER TYPE	FERTILIZER RATE (LBS./SQ. FT.)	FERTILIZER RATE (LBS./ ACRE)	SEASON
10-10-10	.025	1000	FALL

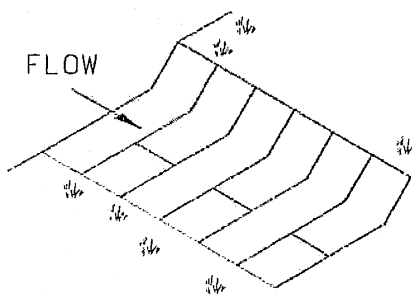

LAY SOD ACROSS THE DIRECTION OF FLOW

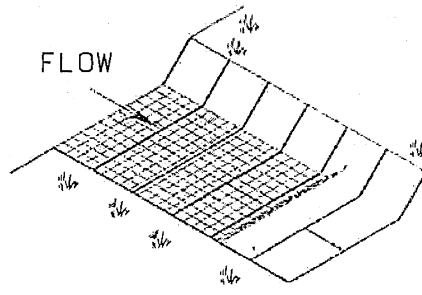

IN CRITICAL AREAS, SECURE SOD WITH NETTING. USE STAPLES.

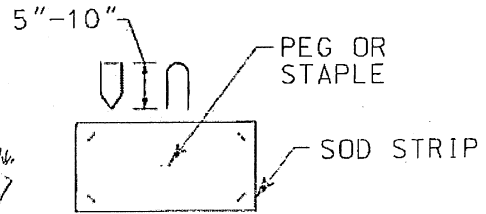

USE PEGS OR STAPLES TO FASTEN SOD FIRMLY AT THE ENDS OF STRIPS AND IN THE CENTER OR EVERY 3-4 FEET IF THE STRIPS ARE LONG. WHEN READY TO MOW, DRIVE PEGS FLUSH WITH THE GROUND.

SOIL PREPARATION:

1. BRING SOIL SURFACE TO FINAL GRADE. CLEAR SURFACE OF TRASH, WOODY DEBRIS, STONES AND CLOUDS LARGER THAN 1". APPLY SOD TO SOIL SURFACES ONLY AND NOT FROZEN SURFACES, OR GRAVEL TYPE SOILS. AS NECESSARY APPLY TOP SOIL. DO NOT USE TOPSOIL RECENTLY TREATED WITH HERBICIDES OR SOIL STERILANTS.

2. MIX FERTILIZER INTO SOIL SURFACE. FERTILIZE BASED ON SOIL TESTS OR FERTILIZING TABLE.

INSTALLATION:

1. LAY SOD WITH TIGHT JOINTS AND IN STRAIGHT LINES. DO NOT OVERLAP JOINTS. STAGGER JOINTS AND DO NOT STRETCH SOD.

2. ON SLOPES STEEPER THAN 3:1, SOD SHOULD BE ANCHORED WITH PINS OR OTHER APPROVED METHODS. INSTALLED SOD SHOULD BE ROLLED OR TAMPED TO PROVIDE GOOD CONTACT BETWEEN SOD AND SOIL.

3. IRRIGATE SOD AND SOIL TO A DEPTH OF 4" IMMEDIATELY AFTER INSTALLATION.

4. SOD SHOULD NOT BE CUT OR SPREAD IN EXTREMELY WET OR DRY WEATHER. IRRIGATION SHOULD BE USED TO SUPPLEMENT RAINFALL FOR A MINIMUM OF 2 -3 WEEKS



City of Opportunity. Moving Forward!

DETAIL 02270-20(D)
DISTURBED AREA STABILIZATION
APPLICATION TABLE

Ds4

APPLICATION TABLE

<u>SEASON</u>	<u>KIND OF SEED</u>	<u>POUNDS PER ACRE</u>
JAN.1 - MAY 15	UNHULLED COMMON BERMUDA	45
	KENTUCKY 31 FESCUE	300
	REBEL II SUPREME	150
MAY 16 - SEPT. 1	HULLED COMMON BERMUDA	75
SEPT.2 - DEC. 31	UNHULLED COMMON BERMUDA	45
	KENTUCKY 31 FESCUE	300
	REBEL II SUPREME	150

1. THE SEED SHALL BE UNIFORMLY SOWN BY APPROVED MECHANICAL POWER DRAWN DRILLS OR, IN SMALL AREAS, BY MECHANICAL HAND SEEDERS. THE SEEDS SHALL BE COVERED AND COMPACTED TO A DEPTH OF $\frac{1}{8}$ TO $\frac{1}{2}$ INCH BY MEANS OF A CULTIPACKER AND AN EMPTY TRAFFIC ROLLER OR ANOTHER ROLLER WEIGHING LESS THAN 3 TONS. BROADCAST SEEDING AND FERTILIZING SHALL NOT BE DONE WHEN THE WIND MAKES IT DIFFICULT TO GET SATISFACTORY DISTRIBUTION.
2. COMMERCIAL FERTILIZER GRADE 18 - 46 - 0 SHALL THEN BE DISTRIBUTED UNIFORMLY AT THE RATE OF 80 LBS. PER ACRE AND SHALL BE UNIFORMLY MIXED WITH THE SOIL TO A DEPTH OF AT LEAST 4 INCHES BY DISKING.



City of Opportunity. Moving Forward!

DETAIL 02270-22 MATTING AND BLANKETS

Mb

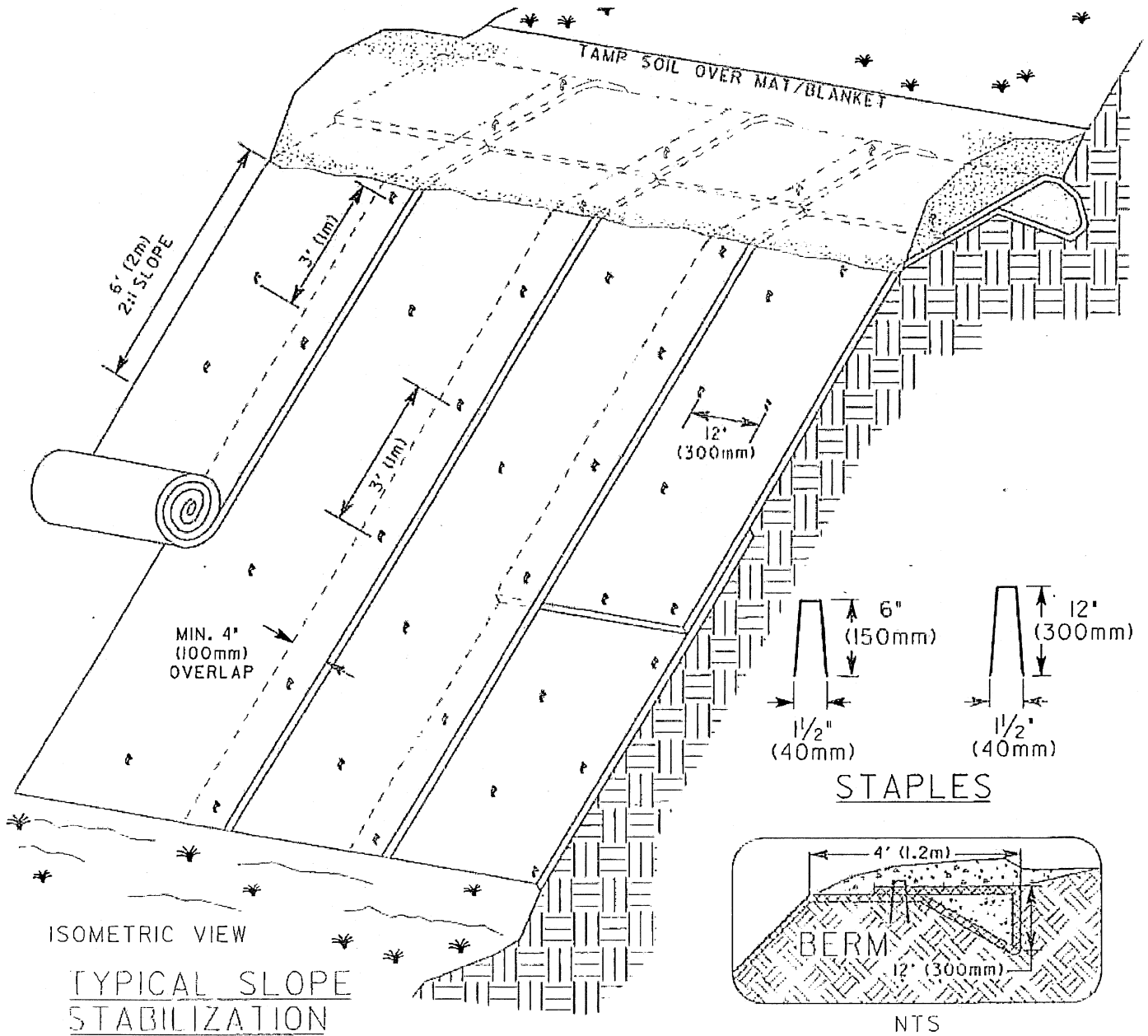

TYPICAL SLOPE STABILIZATION

NOTES:

1. MATS/ BLANKETS SHOULD BE INSTALLED VERTICALLY DOWNSLOPE.
2. SLOPE SURFACE SHALL BE FREE OF CLODS,STICKS, AND GRASS. MATS/BLANKETS SHALL HAVE GOOD SOIL CONTACT.
3. APPLY PERMANENT SEEDING BEFORE PLACING BLANKETS.
4. LAY BLANKETS LOOSELY AND STAKE OR STAPLE TO MAINTAIN DIRECT CONTACT WITH THE SOIL. DO NOT STRETCH.



City of Opportunity. Moving Forward!

DETAIL 02510-1 DRIVEWAY REPLACEMENT

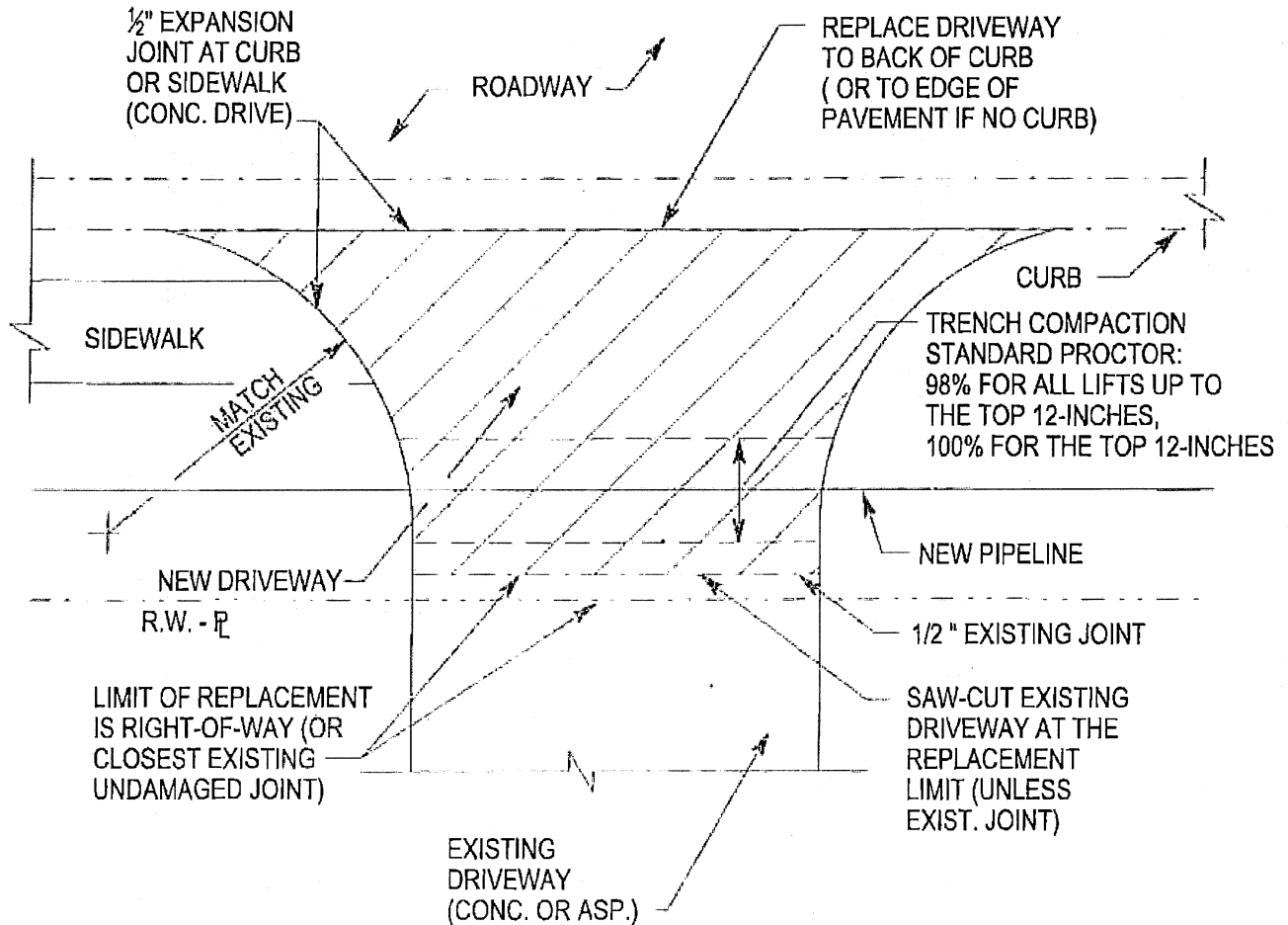

REPLACEMENT REQUIREMENTS :

CONCRETE DRIVEWAY : 6" THICK, 3000 P.S.I. CONC.; REINFORCED
W/6"x 6", W2.0 x W2.0 WELDED WIRE MESH;
BROOM FINISH

ASPHALT DRIVEWAY : 1 1/2" TYPE "E" OR "F" SURFACING ON
6" GRADED AGGREGATE BASE



City of Opportunity. Moving Forward!

DETAIL 02510-2 CONCRETE TRENCH CAP AND ASPHALT PAVEMENT TRENCH PATCH

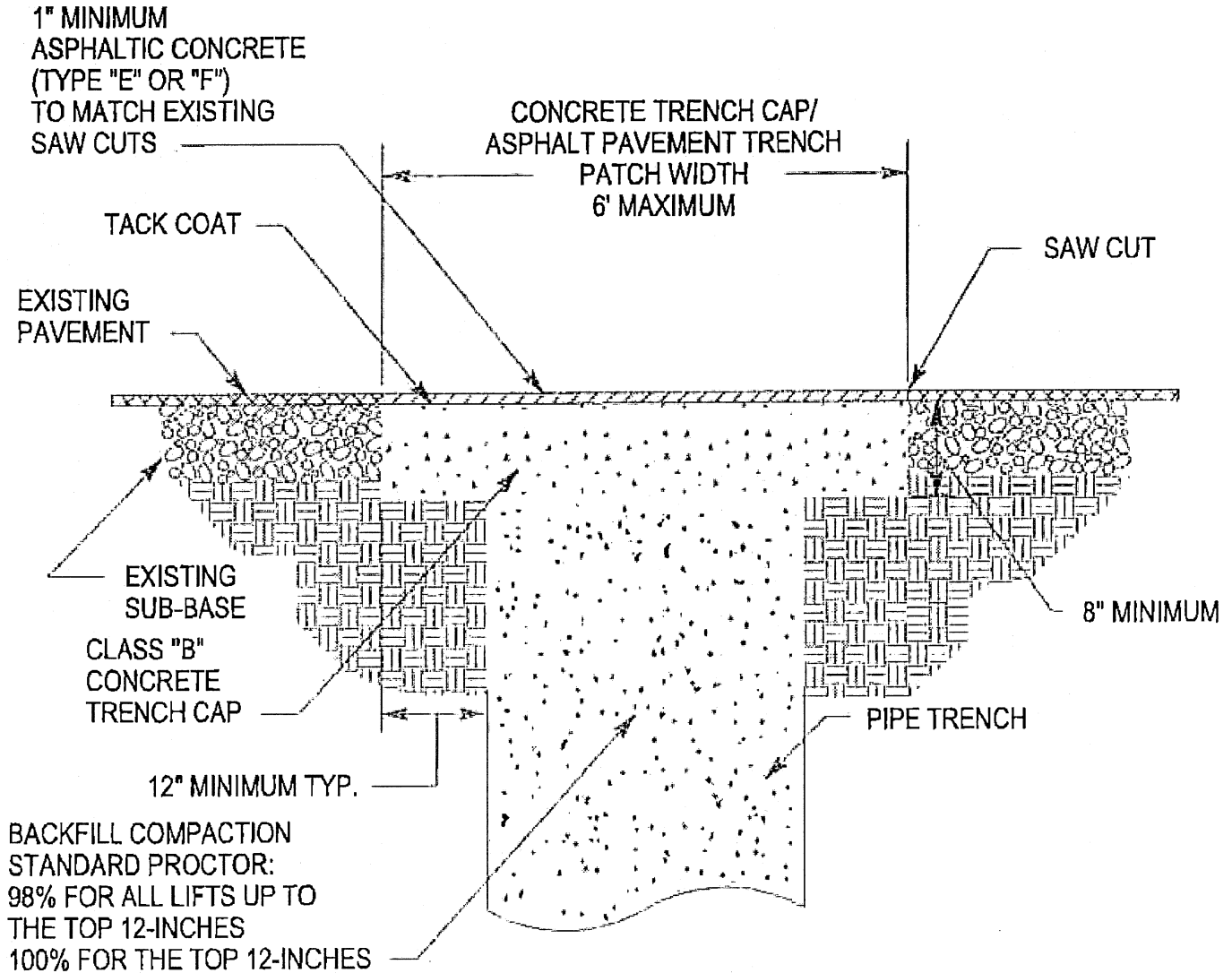



City of Opportunity. Moving Forward!

DETAIL 02510-3 CONCRETE TRENCH CAP AND ASPHALT PAVEMENT OVERLAY

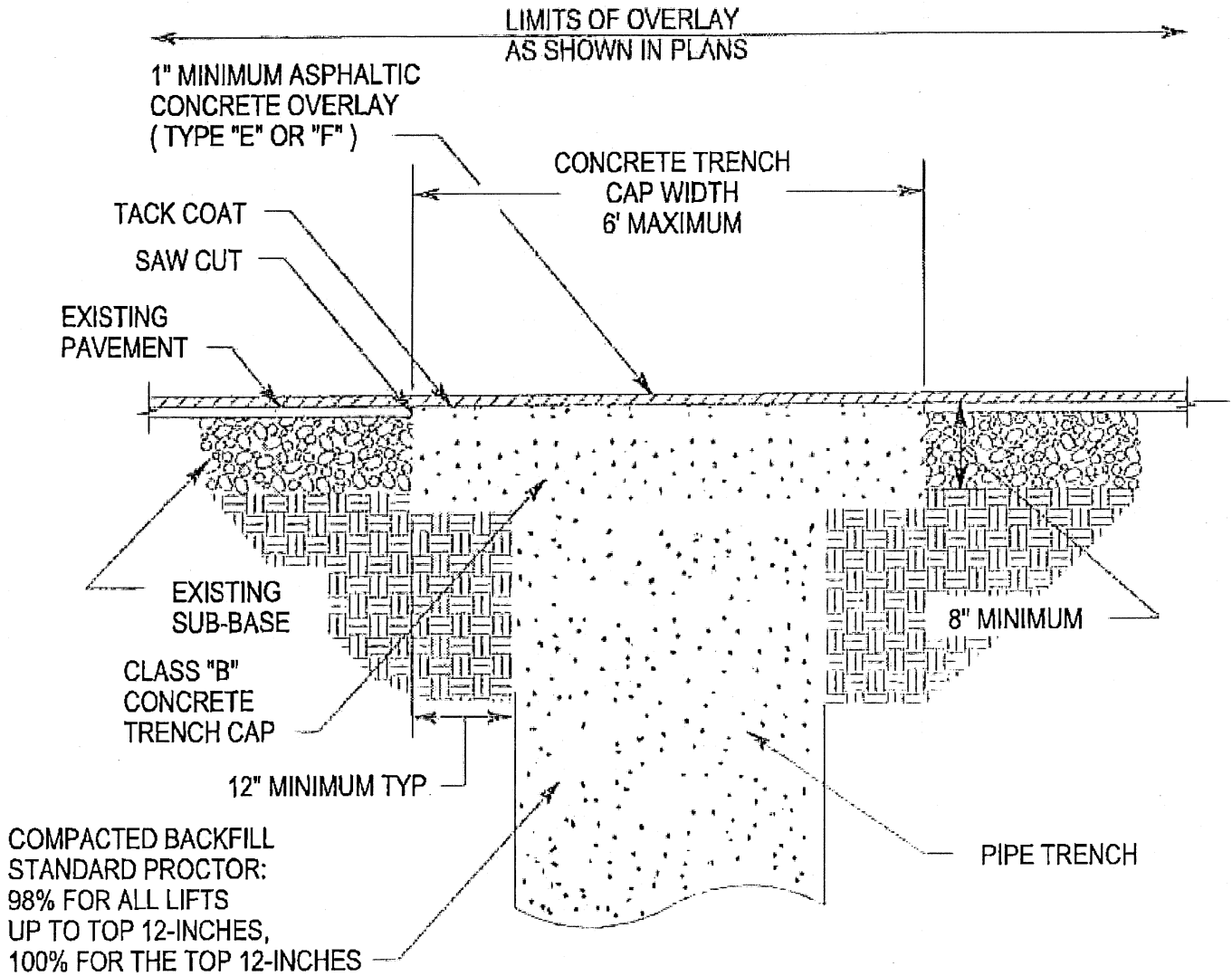



City of Opportunity. Moving Forward!

DETAIL 02510-5 GRADED AGGREGATE BASE / ASPHALT BINDER / ASPHALT SURFACE PAVEMENT REPLACEMENT

1 1/2" MINIMUM
ASPHALTIC CONCRETE
SURFACE COURSE
(TYPE "E" OR "F")
TO MATCH EXISTING
SAW CUTS

2" MINIMUM ASPHALTIC
CONCRETE BASE COURSE
(TYPE "B")

TACK COAT

SAW CUT

EXISTING
PAVEMENT

EXISTING
SUB-BASE

12" MINIMUM TYP.

COMPACTED BACKFILL
STANDARD PROCTOR:
98% FOR ALL LIFTS UP TO
THE TOP 12-INCHES
100% FOR THE TOP 12-INCHES

PIPE TRENCH

6" MINIMUM COMPACTED
GRADED AGGREGATE BASE
100% COMPACTED
AND PRIMED

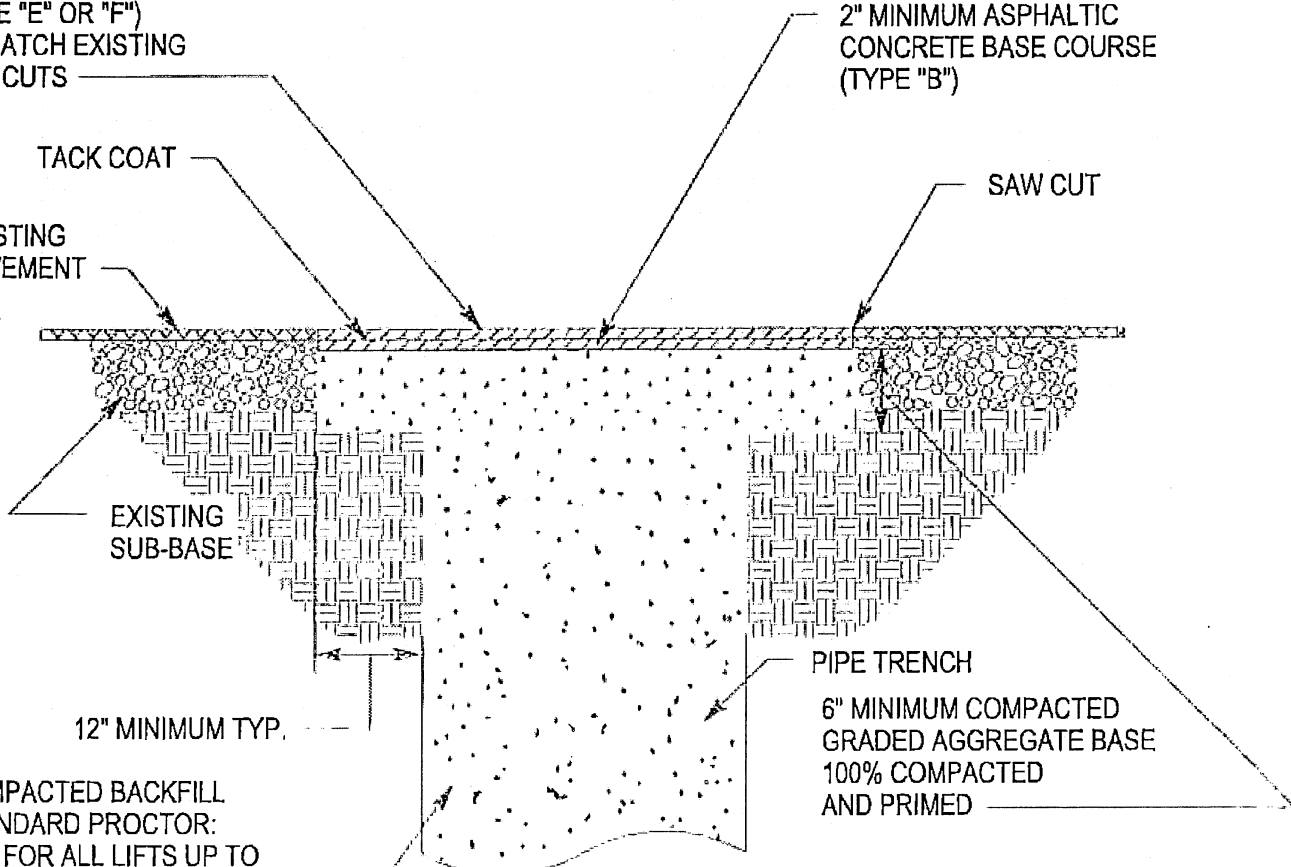



City of Opportunity. Moving Forward!

DETAIL 02510-06 TYPE B ASPHALT BINDER TRENCH CAP (FOR LOCATIONS SUBJECT TO SUBSEQUENT MILLING / PROFILING AND RESURFACING)

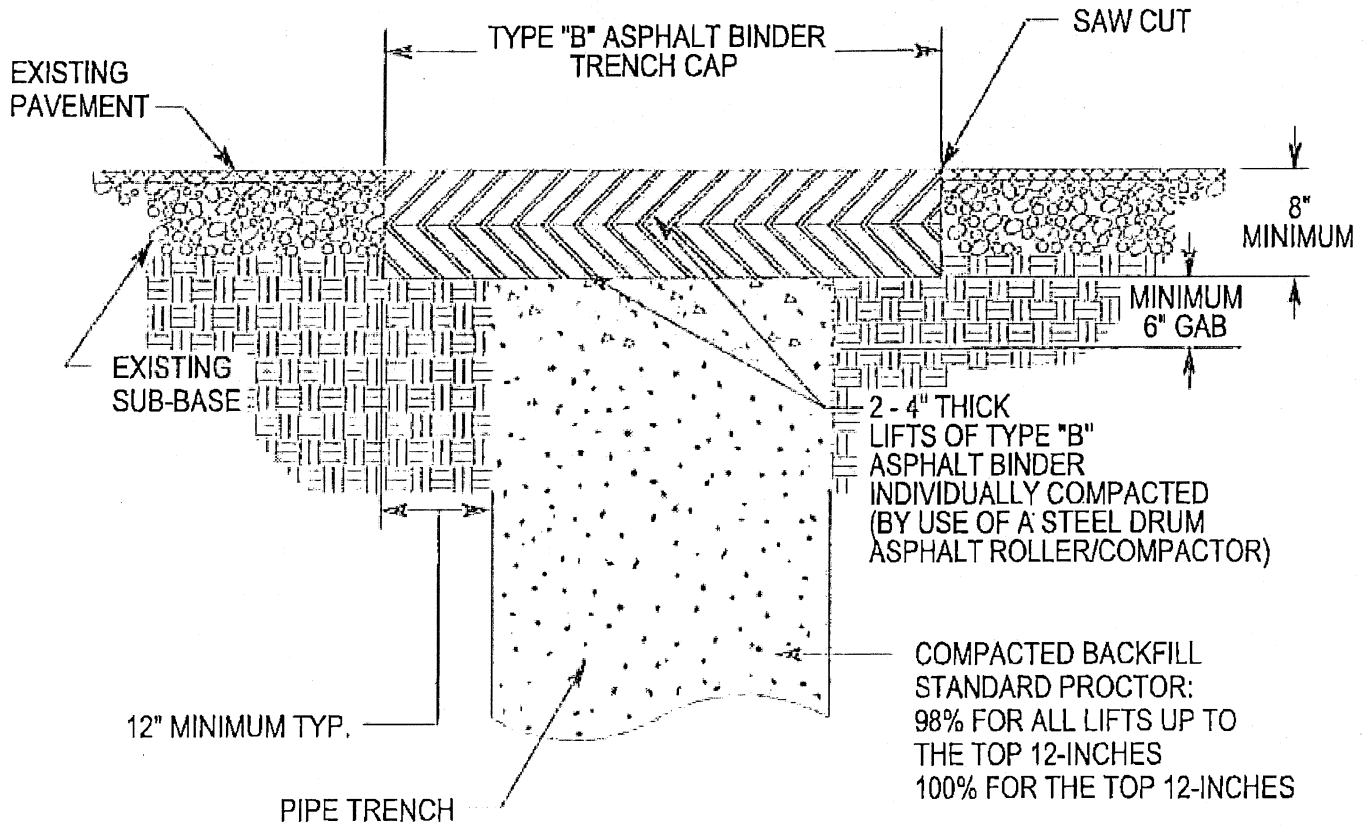



City of Opportunity. Moving Forward!

DETAIL 2713-1 WATER MAIN TRENCH DETAIL

- BACKFILL COMPACTION
STANDARD PROCTOR:
- A) UNPAVED AREAS OUTSIDE OF ROADWAY RIGHT-OF-WAYS - 90% FOR ALL LIFTS
 - B) UNPAVED AREAS OF ROADWAY RIGHT-OF-WAY - 98% FOR ALL LIFTS
 - C) PAVED AREAS - 98% FOR ALL LIFTS UP TO THE TOP 12-INCHES, 100% FOR THE TOP 12-INCHES

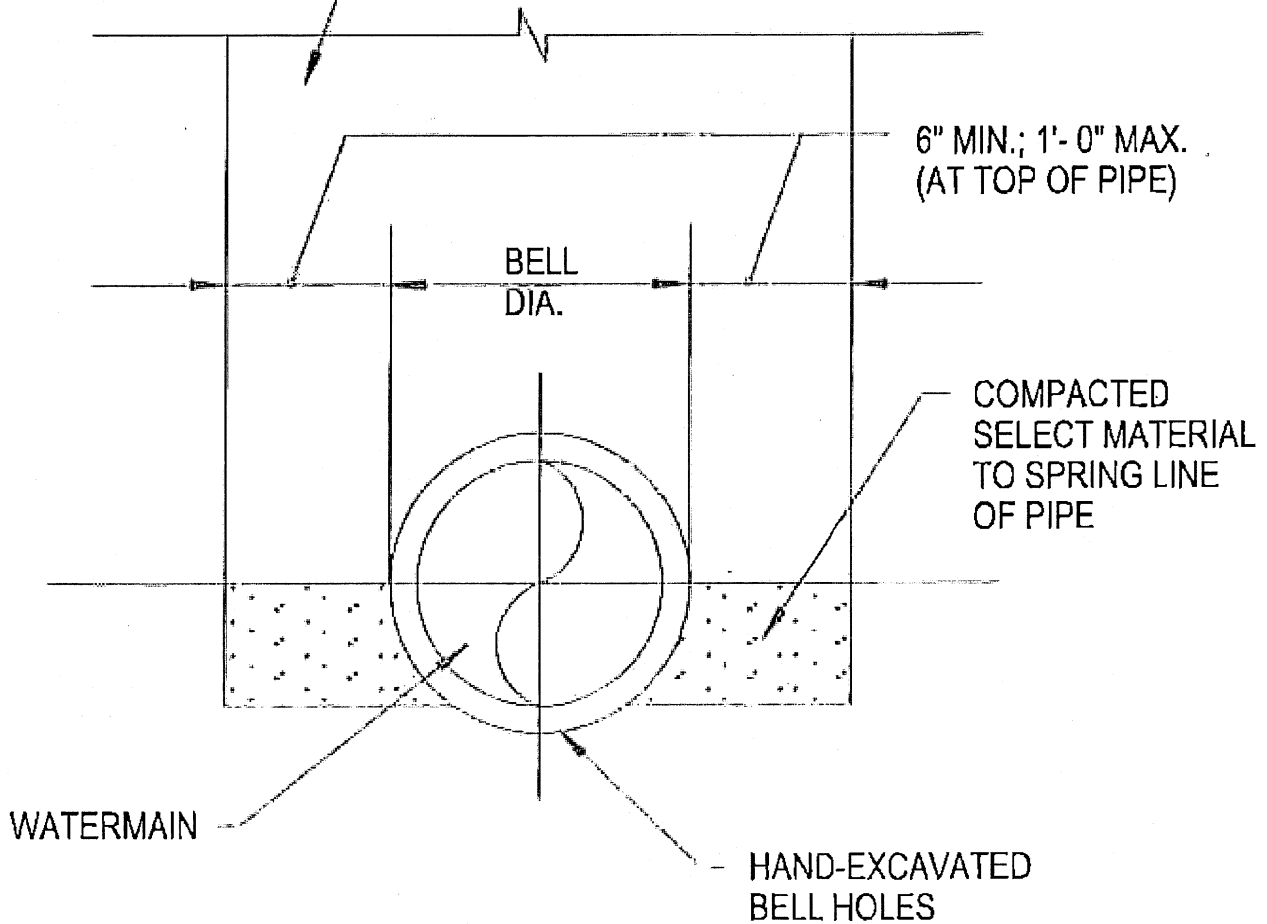



City of Opportunity. Moving Forward!

DETAIL 2713-2 FIRE HYDRANT INSTALLATION (SUBDIVISION STANDARD)

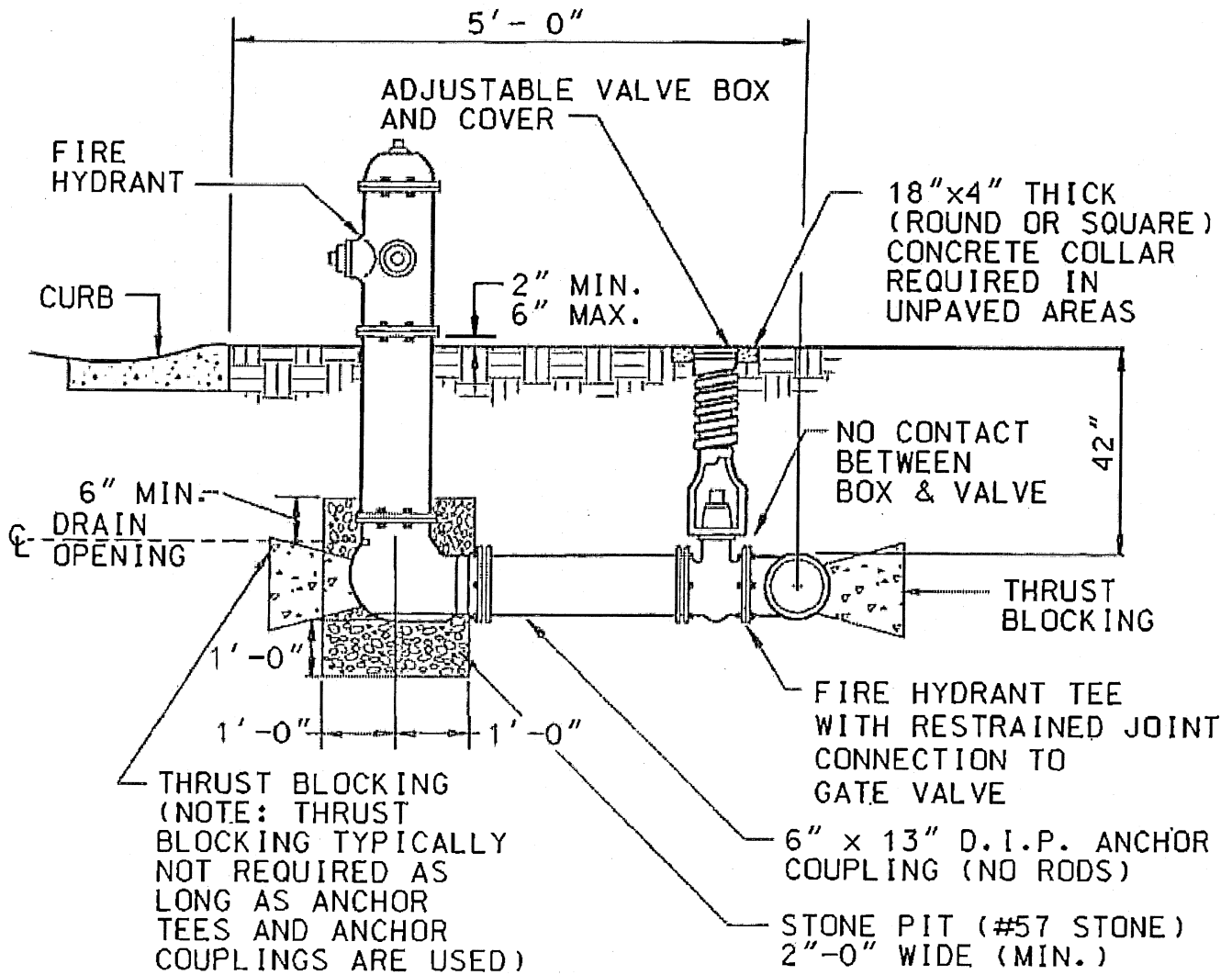

TYPICAL SECTION



City of Opportunity. Moving Forward!

DETAIL 2713-3 FIRE HYDRANT INSTALLATION (ROADWAY STANDARD)

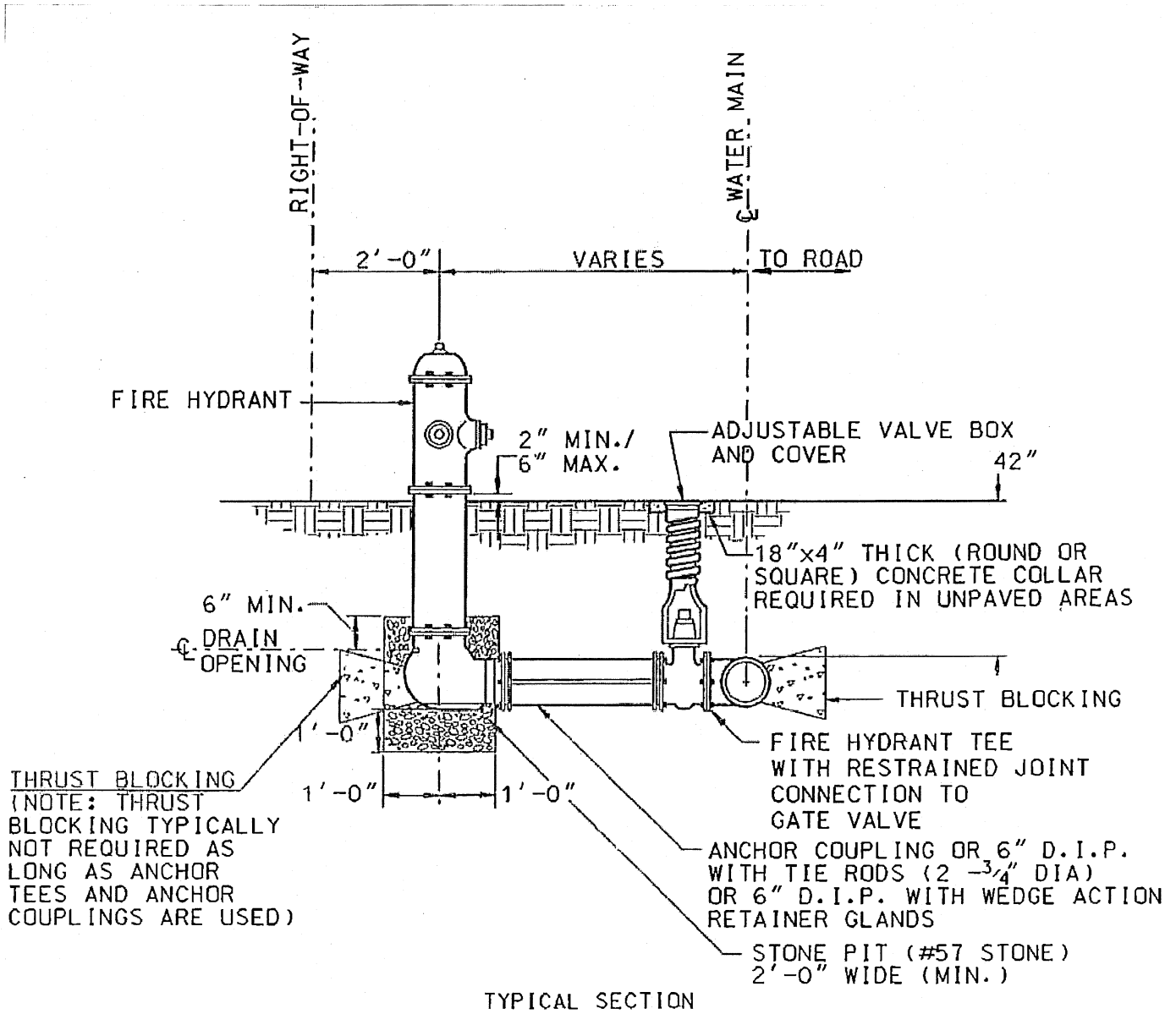

- NOTES:
1. TIE RODS TO BE ALLOY STEEL WITH MIN. TENSILE STRENGTH OF 125,000 P.S.I.. RODS TO BE COATED WITH BITUMINOUS PAINT AFTER INSTALLATION.
 2. WEDGE ACTION RETAINER GLANDS SHALL BE EBAA IRON MEGALUG, FORD UNI-FLANGE SERIES 1400, OR EQUAL.



City of Opportunity. Moving Forward!

DETAIL 2713-4 VALVE INSTALLATION

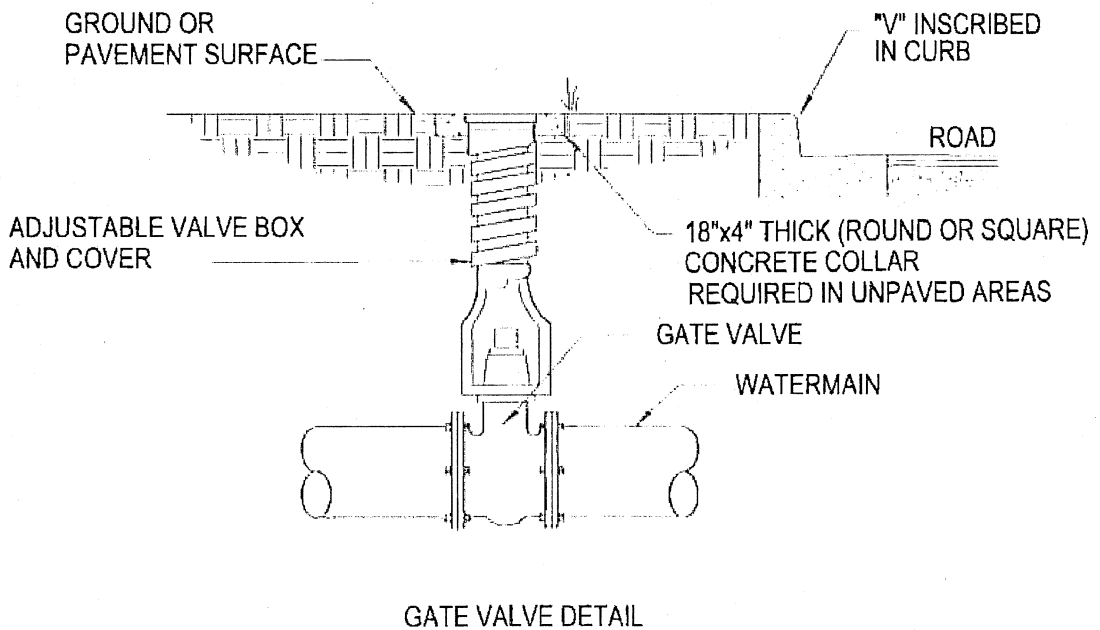
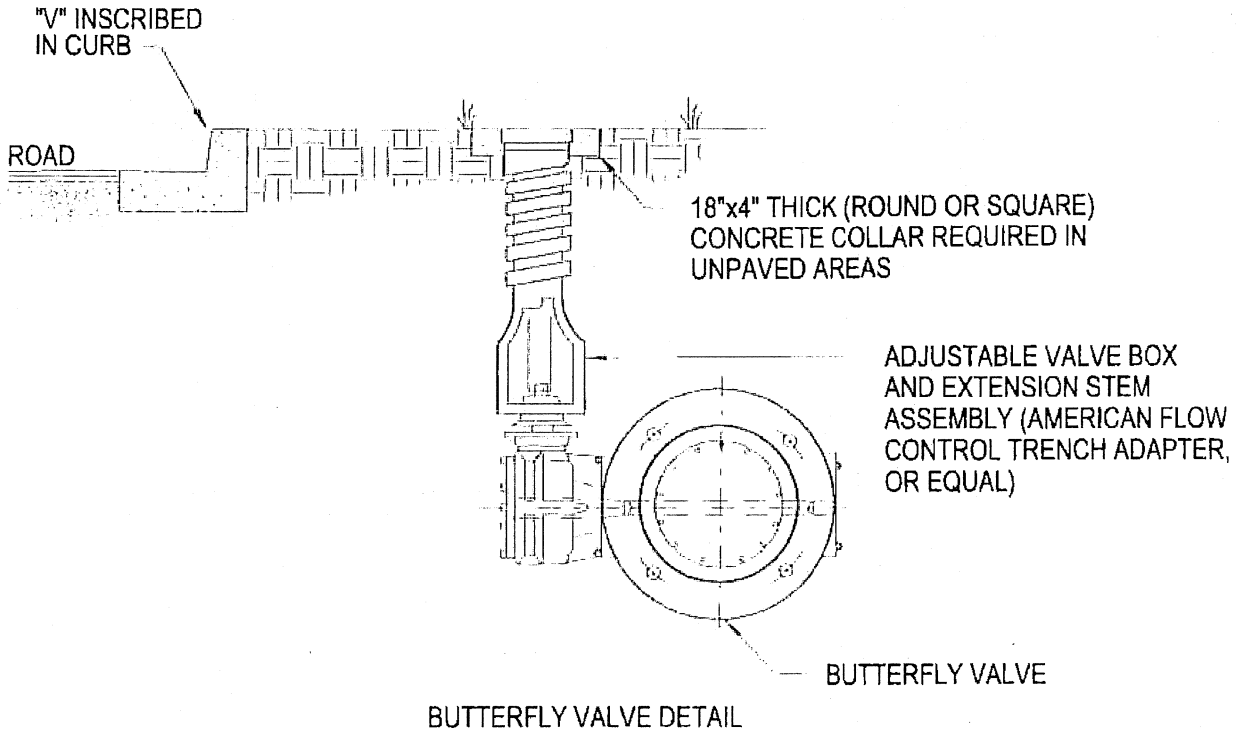



City of Opportunity. Moving Forward!

DETAIL 2713-5 CONCRETE VALVE MARKER

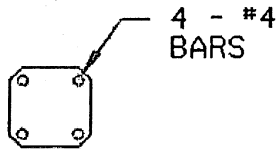

4 - #4
BARS

SECTION

'WATER' CAST
IN MARKER
POST ON TWO
SIDES

CHAMFER
ALL EDGES

ALUMINUM PLATE CAST IN MARKER ;
DISTANCE TO VALVES (RELATIVE TO MARKER)
SHALL BE CLEARLY STAMPED ON PLATE
WITH STEEL DIE AFTER MARKER IS SET.

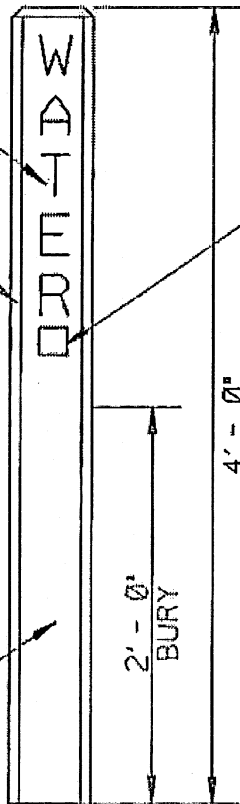

2,500 PSI
CONCRETE (MIN.)



City of Opportunity. Moving Forward!

DETAIL 2713-6 LINE ABANDONMENT AT VALVE

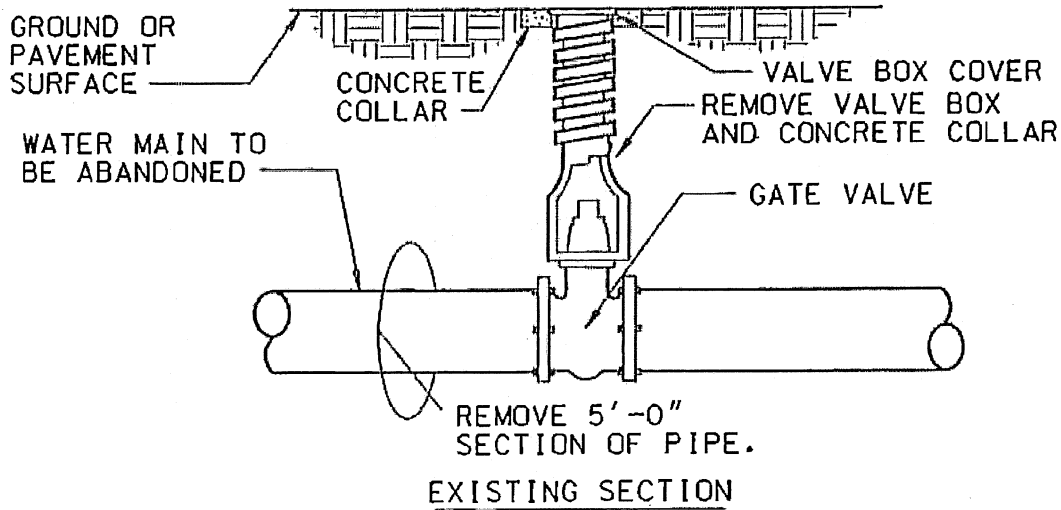

BACKFILL EXCAVATION TO REQUIRED COMPACTION STANDARDS

ISOLATE WATER LINE FROM PRESSURE OR SECURE VALVE TO PREVENT BLOW-OFF. DURING PIPE REMOVAL PROCESS

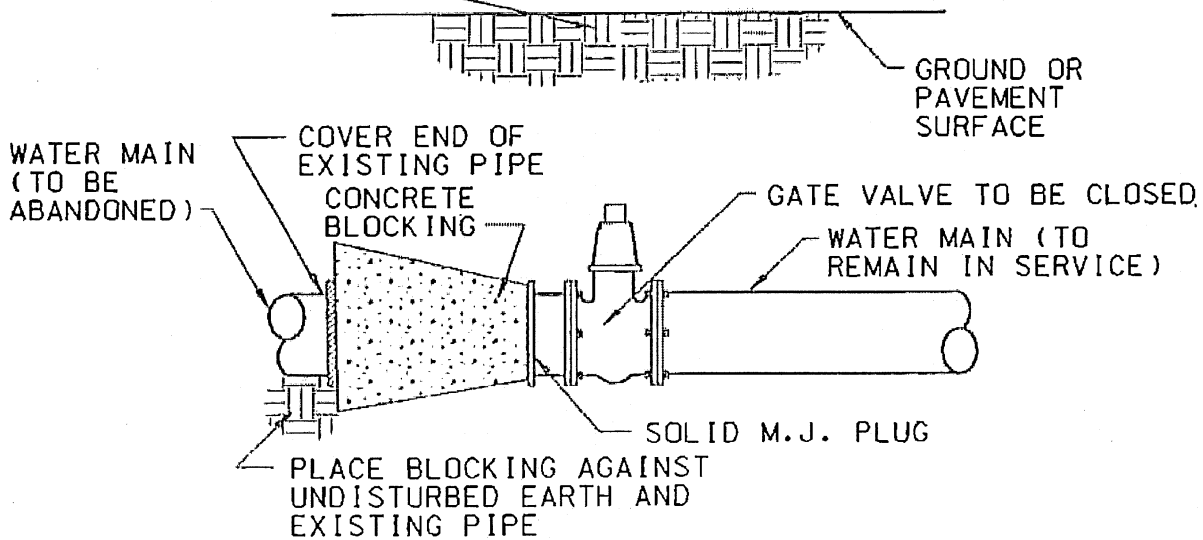

REVISED SECTION



City of Opportunity. Moving Forward!

DETAIL 2713-7 VALVE ABANDONMENT

REMOVE VALVE BOX
AND VALVE PAD;
FILL VOID WITH SELECT
MATERIAL AND
COMPACT

REMOVE COVER AND
FILL VALVE BOX WITH
CRUSHED STONE AND
CONCRETE; SCREED FLUSH
WITH PAVEMENT

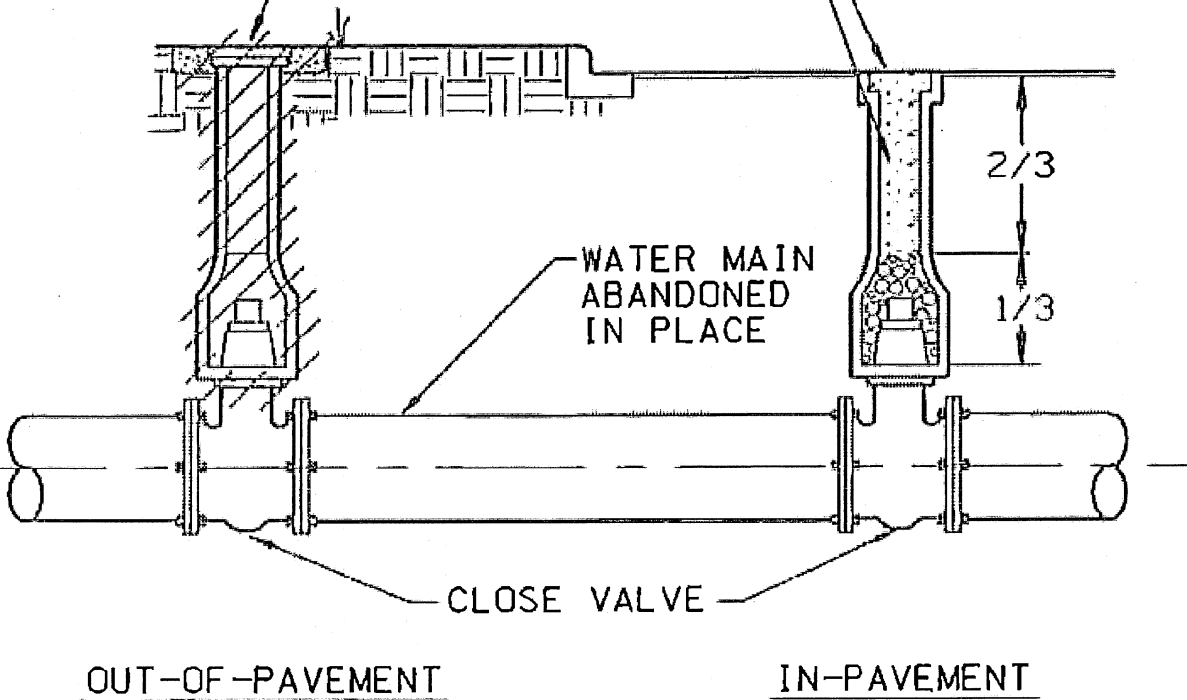

NOTE : REMOVE ANY VALVE MARKERS
ASSOCIATED WITH ABANDONED VALVES



City of Opportunity. Moving Forward!

DETAIL 2713-8 WATER LINE VALVING AT INTERSECTION

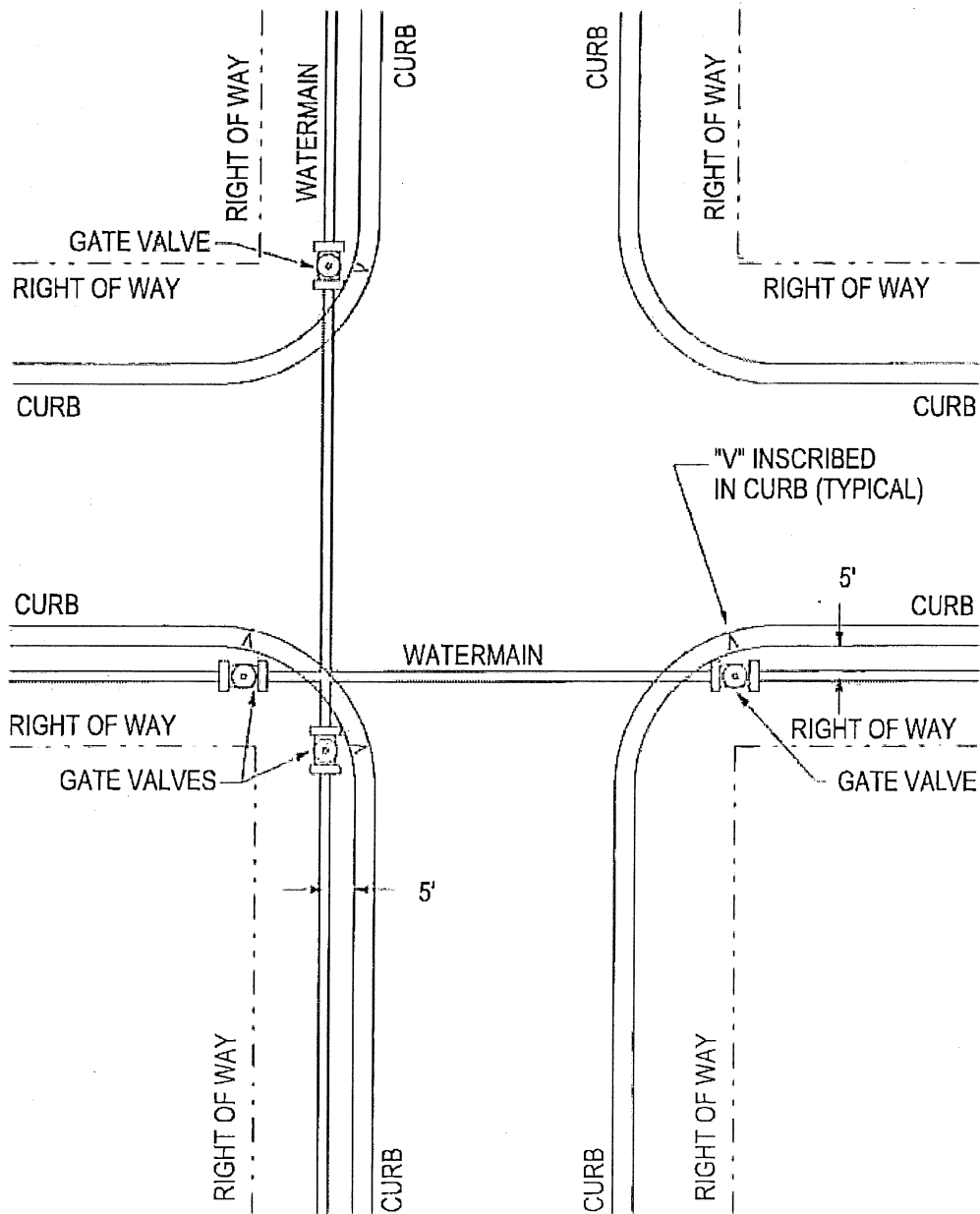

1. VALVES ARE TO BE LOCATED 5'-0" BEHIND THE CURB IN THE RIGHT OF WAY
2. VALVES SHALL NOT BE LOCATED IN THE DITCH LINE



City of Opportunity. Moving Forward!

DETAIL 2713-9(B) DEAD-END FIRE HYDRANT INSTALLATION (NEW INSTALLATIONS)

INSTALL
1 - 6"x 6" M.J. HYDRANT TEE
1 - 6" GATE VALVE
1 - 6" PLUG
1 - ANCHOR COUPLING
1 - FIRE HYDRANT
1 - THRUST BLOCK (SEE DETAIL 02713-12
TEE/PLUG FOR CORRECT DIMENSIONS)

NOTE:
PLACE FIRE HYDRANT
AT / NEAR PROPERTY LINE
WITHIN 2' OF RIGHT-OF-WAY

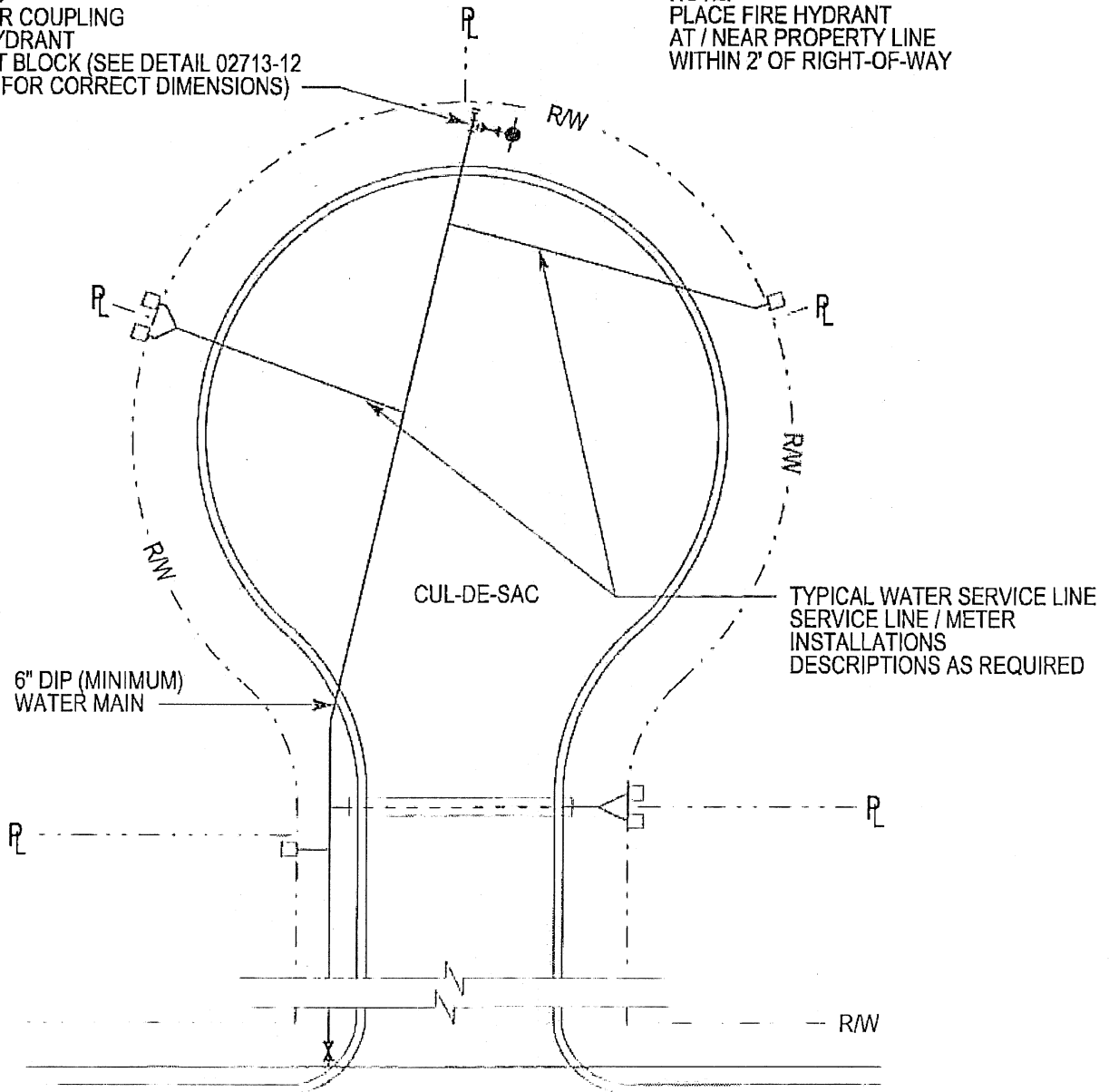



City of Opportunity. Moving Forward!

DETAIL 2713-11(A) RESIDENTIAL CUL-DE-SAC COPPER WATERLINE SIZING WITH FIRE HYDRANT

NOTE:
ASSUME WATER LINE LINE PRESSURE APPROXIMATELY 80 PSI.
15 GPM PER METER MAXIMUM FLOW FOR ALL METERS.
ALL COPPER IS TYPE K, FLARED CONNECTIONS.

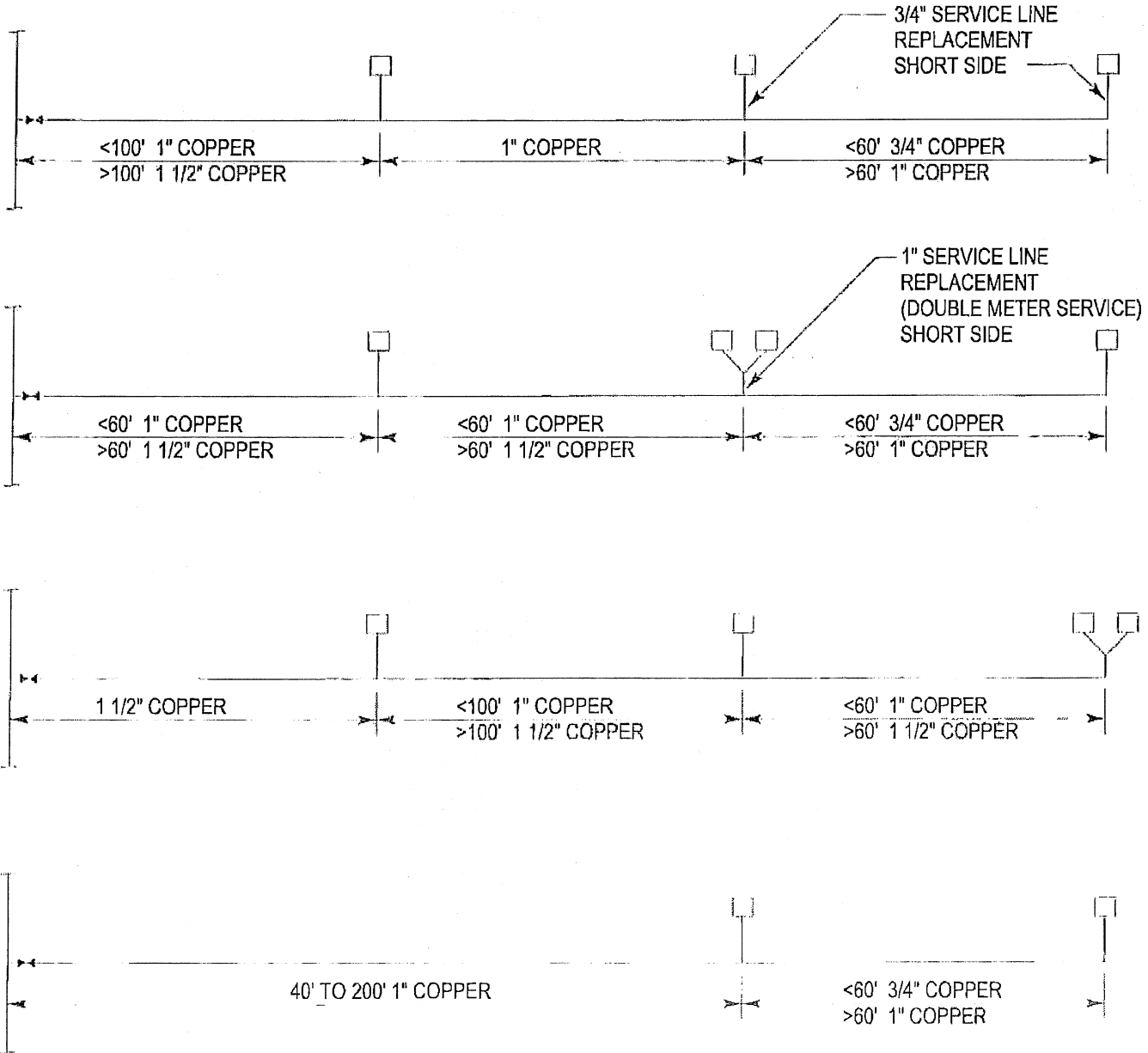



City of Opportunity. Moving Forward!

DETAIL 2713-11(B) RESIDENTIAL CUL-DE-SAC COPPER WATERLINE SIZING WITHOUT FIRE HYDRANT

NOTE:
ASSUME WATER LINE LINE PRESSURE APROXIMATELY 80 PSI.
15 GPM PER METER MAXIMUM FLOW FOR ALL METERS.
ALL COPPER IS TYPE K, FLARED CONNECTIONS.

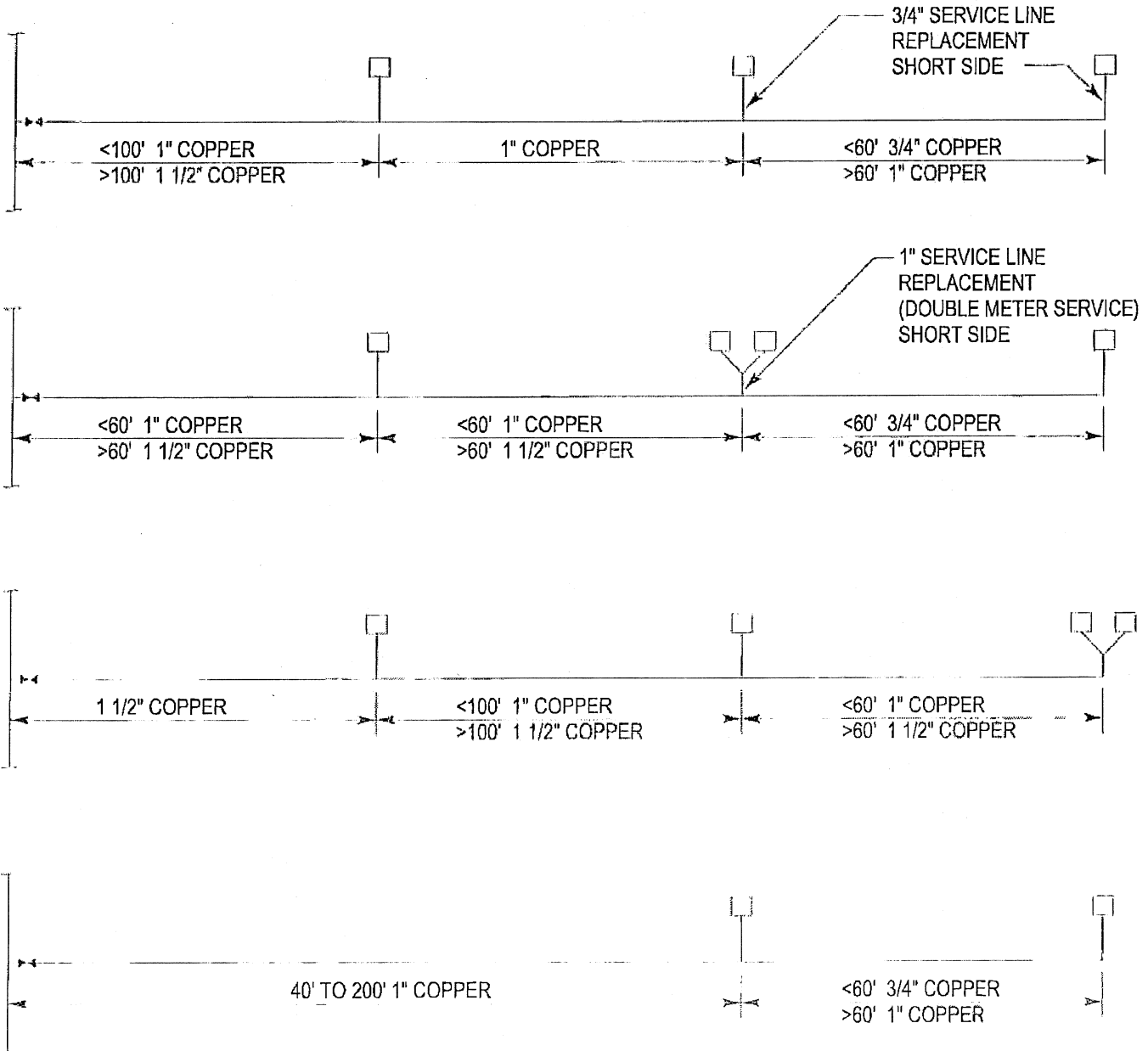



City of Opportunity. Moving Forward!

DETAIL 2713-11(C) CURB STOP VALVING FOR 1" COPPER WATER MAIN

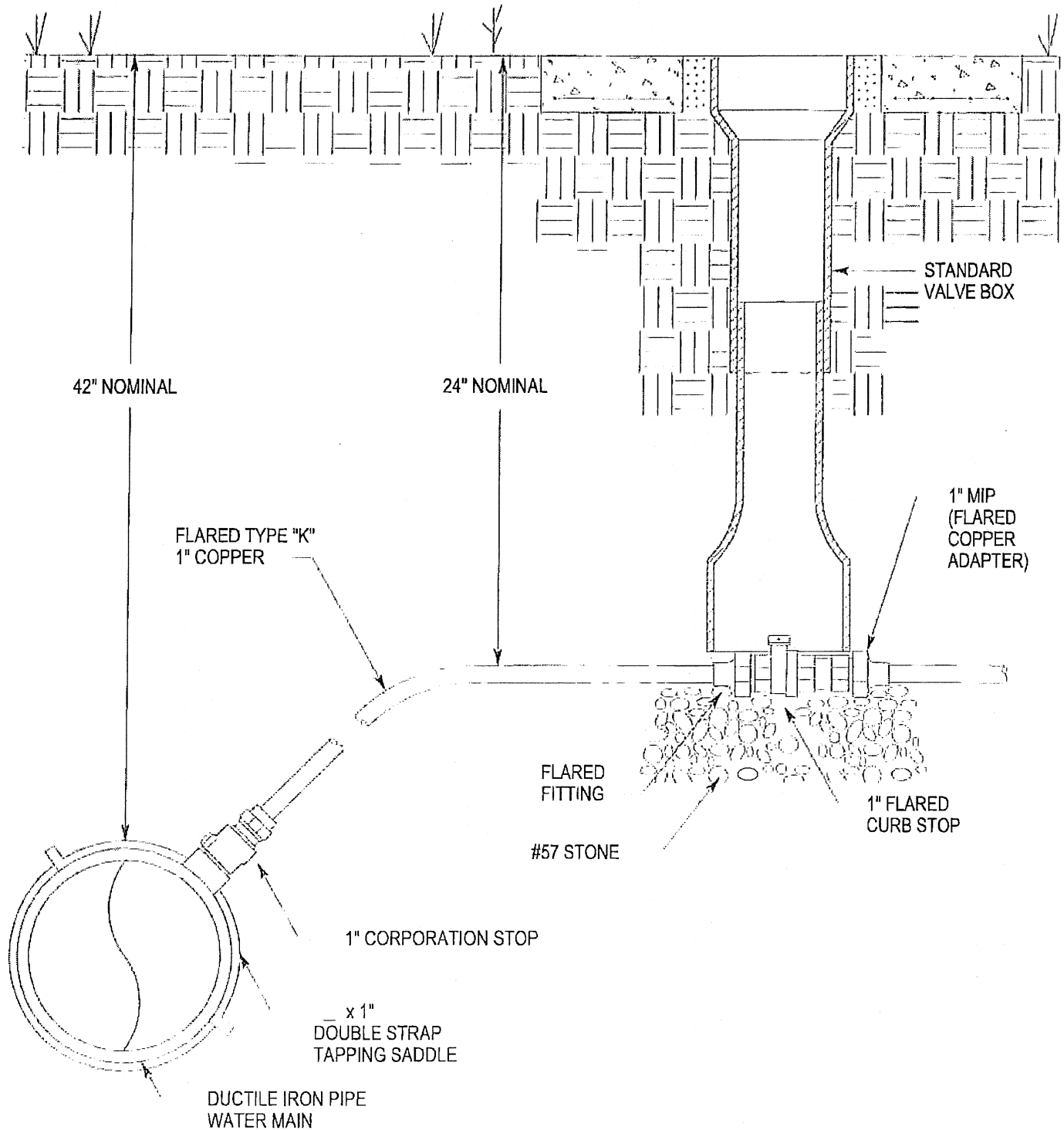



City of Opportunity. Moving Forward!

DETAIL 2713-11(D) CURB STOP VALVING FOR 1 1/2" COPPER WATER MAIN

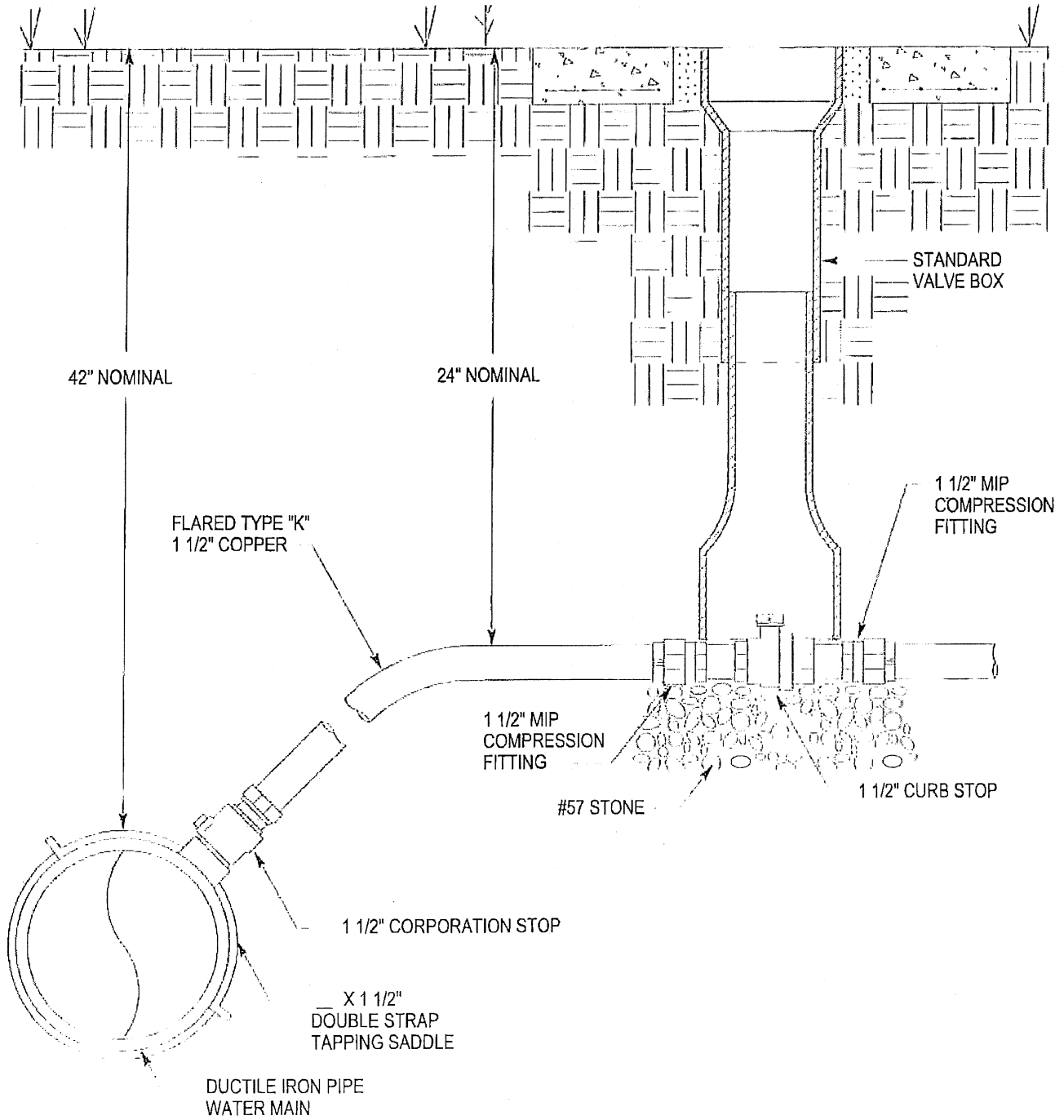



City of Opportunity. Moving Forward!

DETAIL 2713-12(A) THRUST BLOCKING

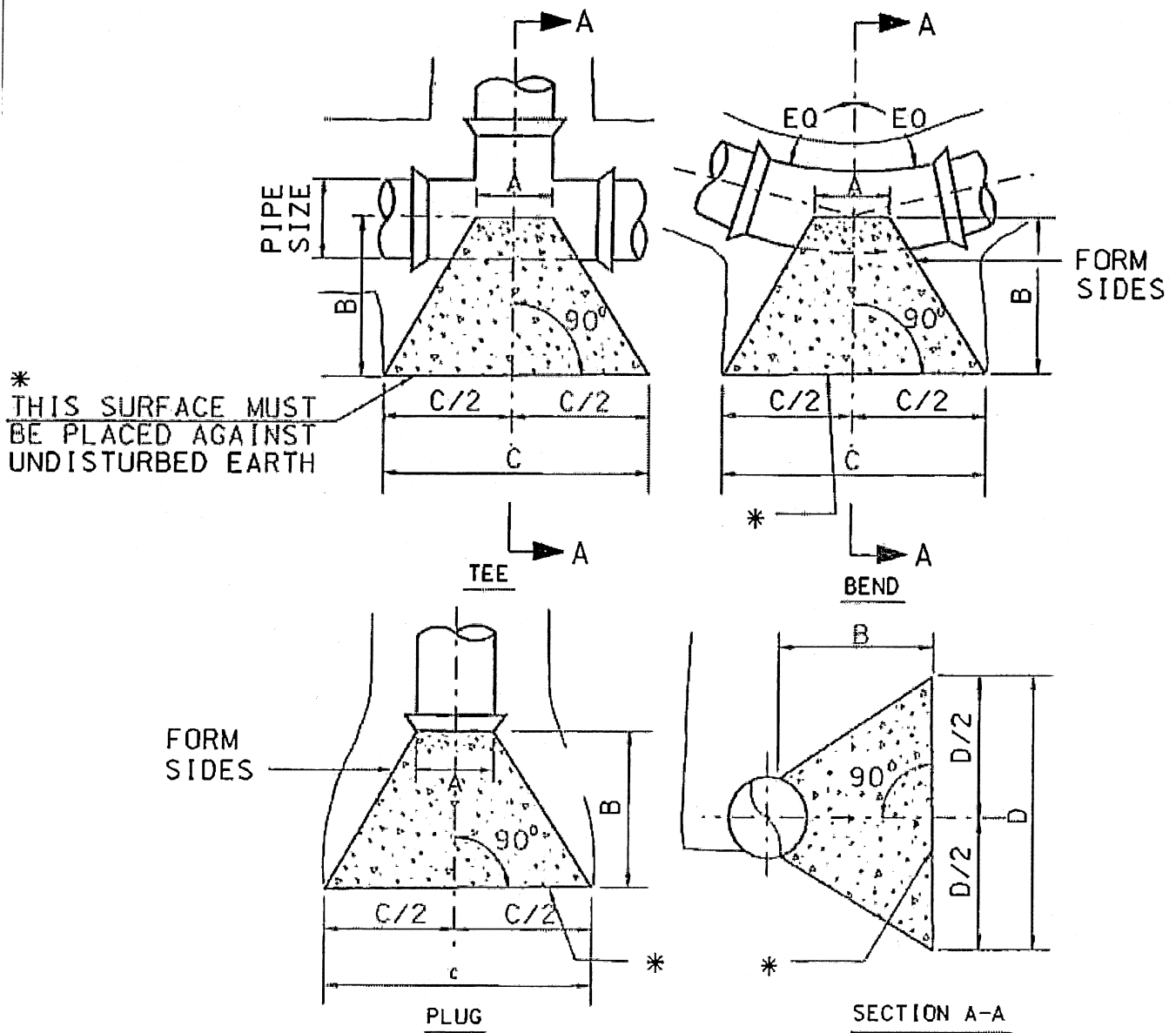

- NOTES: 1. SEE DETAIL 02713-12B FOR DIMENSION TABLES
 2. COVER CONTACT SURFACE ON JOINT WITH ROOFING FELT PRIOR TO PLACEMENT OF CONCRETE



City of Opportunity. Moving Forward!

DETAIL 2713-12(B) THRUST BLOCK DIMENSIONS

FITTING	PIPE DIA. (IN.)	THRUST	BLOCK	DIM.	(FEET)	APPROX. VOL. (C.Y.)	BEARING AREA (SQ. FT.)	DESIGN THRUST (LBS.)
		A	B	C	D			
90° BEND	6	1.0	1.6	3.9	2.4	0.30	9.3	18,500
	8	1.2	2.1	5.2	3.1	0.66	15.9	31,825
	10	1.5	2.5	6.3	3.8	1.23	23.9	47,875
	12	1.7	3.0	7.5	4.5	2.05	33.8	67,705
	14	2.0	3.5	8.7	5.2	3.20	45.5	90,960
	16	2.2	4.0	9.9	5.9	4.69	68.8	117,645
	18	2.5	4.5	11.1	6.8	6.61	73.9	147,755
	20	2.7	5.0	12.3	7.1	8.95	90.6	181,290
45° BEND	24	3.3	5.9	14.7	8.8	15.31	129.3	258,650
	6	0.5	1.2	2.9	1.7	0.11	5.0	10,015
	8	0.6	1.5	3.8	2.3	0.25	8.6	17,230
	10	0.8	1.9	4.6	2.8	0.47	13.0	25,920
	12	0.9	2.2	5.5	3.3	0.79	18.3	36,855
	14	0.9	2.6	6.4	3.8	1.21	24.6	49,250
	16	1.0	2.9	7.3	4.4	1.78	31.8	63,695
	18	1.1	3.3	8.2	4.9	2.50	40.0	80,000
22 1/2° BEND	20	1.2	3.6	9.0	5.4	3.40	49.1	98,155
	24	1.5	4.3	10.8	6.5	5.81	70.0	140,040
	6	0.5	0.8	2.1	1.2	0.04	2.6	5,120
	8	0.6	1.1	2.7	1.6	0.10	4.4	8,810
	10	0.8	1.3	3.3	2.0	0.18	6.6	13,250
	12	0.9	1.6	4.0	2.4	0.30	9.4	18,740
	14	0.9	1.8	4.6	2.8	0.46	12.6	25,175
	16	1.0	2.1	5.2	3.1	0.67	16.3	32,560
11 1/4° BEND	18	1.1	2.3	5.8	3.5	0.94	20.4	40,895
	20	1.2	2.6	6.5	3.9	1.28	25.1	50,175
	24	1.5	3.1	7.7	4.6	2.19	35.8	71,585
	6	0.5	0.8	1.5	0.9	0.02	1.3	2,580
	8	0.6	0.8	1.9	1.2	0.04	2.2	4,440
	10	0.8	0.9	2.4	1.4	0.07	3.3	6,675
	12	0.9	1.1	2.8	1.7	0.12	4.7	9,440
	14	0.9	1.3	3.2	2.0	0.17	6.3	12,680
TEE /PLUG	16	1.0	1.5	3.7	2.2	0.25	8.2	16,400
	18	1.1	1.7	4.2	2.5	0.35	10.3	20,595
	20	1.2	1.8	4.6	3.3	0.48	12.6	25,270
	24	1.5	2.2	5.5	5.8	0.83	18.0	36,055
	6	1.0	1.3	3.3	2.0	0.19	6.5	13,080
	8	1.2	1.7	4.3	2.6	0.41	11.2	22,500
	10	1.5	2.1	5.3	3.2	0.76	16.9	33,850
	12	1.7	2.5	6.3	3.8	1.26	23.9	47,870
TEE /PLUG	14	2.0	2.9	7.3	4.4	1.97	32.2	64,315
	16	2.2	3.3	8.3	5.0	2.88	41.6	83,185
	18	2.5	3.8	9.3	5.6	4.06	52.2	104,475
	20	2.7	4.2	10.4	6.2	5.49	64.1	128,190
	24	3.3	5.0	12.4	7.4	9.40	91.4	182,885

Thrust Block Notes:

1. The dimensions and values in these tables are based on the following:
 - a. Water main test pressure = 350 p.s.i.
 - b. Horizontal bearing strength of soil = 2,000 p.s.f.
2. The bearing surface of the thrust block shall be placed against undisturbed soil. If this is not possible, the fill between the bearing surface and undisturbed soil shall be compacted to at least 95% Modified Proctor density.



City of Opportunity. Moving Forward!

DETAIL 2713-12(C) THRUST RESTRAINT: CONCRETE COLLAR WITH RODDING SYSTEM

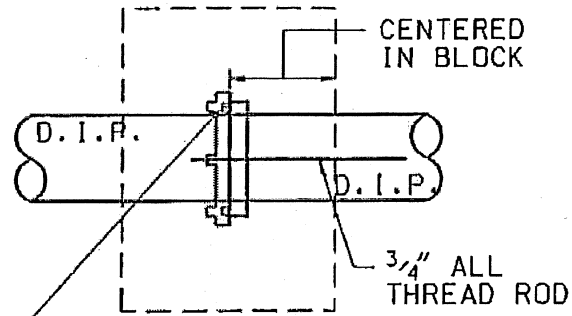
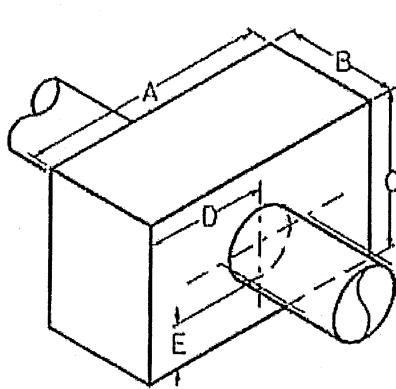

RETAINER GLAND
TORQUE SET SCREWS IN ACCORDANCE
WITH MANUFACTURER'S INSTRUCTIONS.
INSPECTOR MUST WITNESS INSTALLATION.

MINIMUM DIMENSIONS IN FEET FOR CONCRETE COLLAR ON DUCTILE IRON PIPE TO BE USED WITH EMBEDDED DUCTILE IRON RETAINER GLAND

PIPE SIZE	A	B	C	D	E	VOLUME CU. YDS.	CONC. WT.	THRUST
4"	3'-6"	3'-0"	1'-5"	1'-6"	1'-0"	0.55	2230	3150
6"	4'-0"	3'-0"	2'-7"	2'-0"	1'-0"	1.15	4650	7070
8"	4'-6"	3'-0"	3'-0"	2'-3"	1'-3"	1.50	6075	12,570
10"	5'-2"	3'-0"	3'-2"	2'-7"	1'-3"	1.81	7330	19,635
12"	5'-9"	3'-0"	3'-8"	2'-10 ¹ / ₂ "	1'-8"	2.34	9475	28,775
14"	6'-6"	3'-0"	4'-0"	3'-3"	1'-9"	2.89	11,700	38,490
16"	6'-9"	3'-0"	4'-9"	3'-3"	2'-3"	3.56	14,410	50,270

NOTES :

1. ALL WATER MAINS GREATER THAN 18" I.D. SHALL BE INDIVIDUALLY CALCULATED BY C.C.W.S. ENGINEERING DEPARTMENT.
2. SOIL CONDITIONS SHALL BE VERIFIED BY THE ENGINEER BEFORE THRUST RESTRAINT DESIGN IS IMPLEMENTED.
3. PIPE MUST BE DUCTILE IRON.

DESIGN DATA :

1. DIMENSION OF THRUST RESTRAINT IN FEET BASED ON 2000 POUNDS PER SQUARE FOOT SOIL BEARING PRESSURE AND 230' PER SQUARE INCH TEST PRESSURE. ACTUAL INSIDE DIAMETER OF DUCTILE IRON PIPE, CLASS 31, USED AS STANDARD.
2. CONCRETE SHALL BE CLASS A, 3000 P.S.I.
3. UNDER ADVERSE CONSTRUCTION CONDITIONS, CONCRETE SHALL BE "HIGH EARLY" TYPE.



City of Opportunity. Moving Forward!

DETAIL 2713-13 WATER METER LOCATION FOR SUBDIVISION (TYPICAL PLAN)

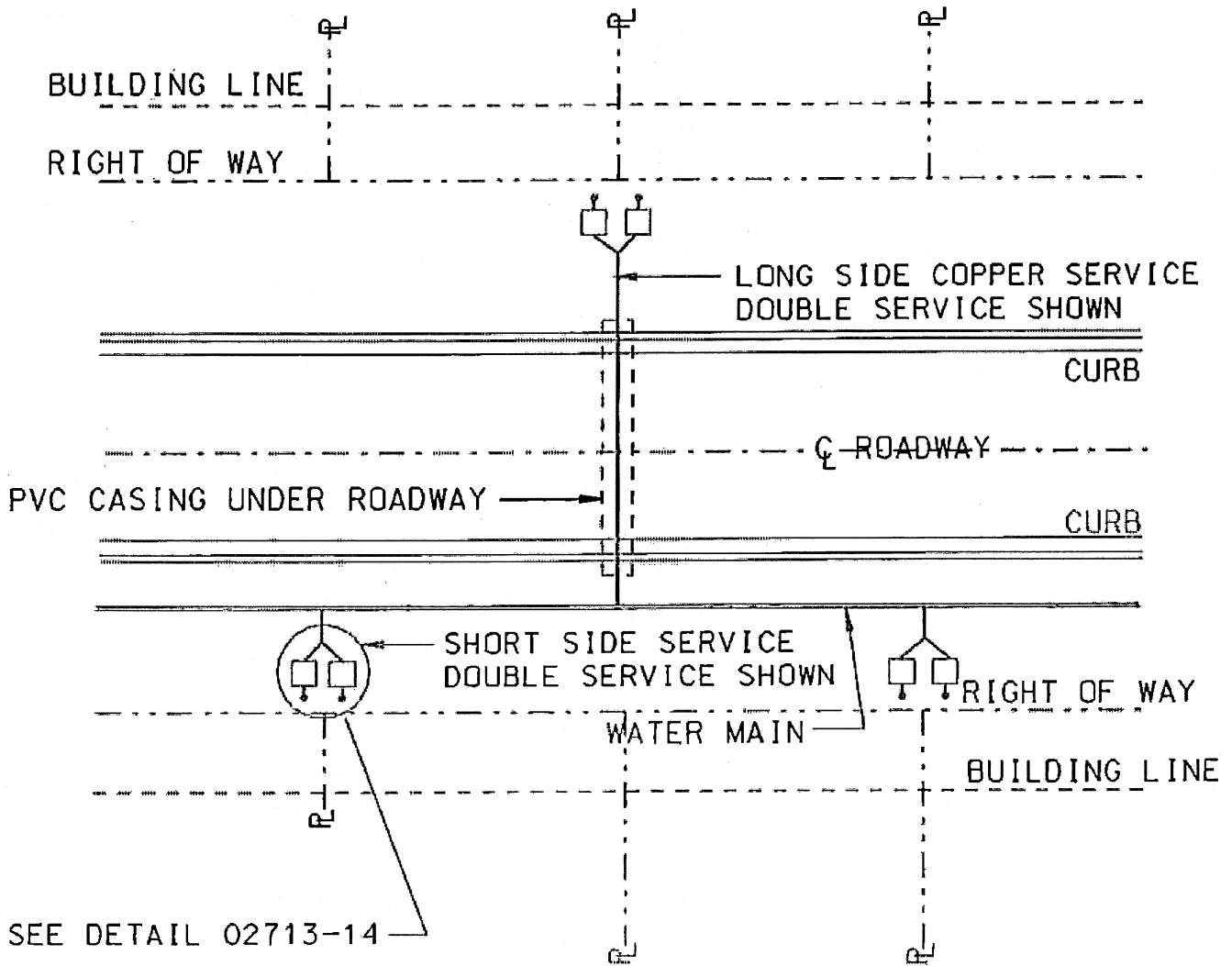

NOTE: DOUBLE SERVICE NOT ALLOWED ABOVE ELEVATION 1140.



City of Opportunity. Moving Forward!

DETAIL 2713-14A 3/4" WATER METER INSTALLATION (TYPICAL SECTION)

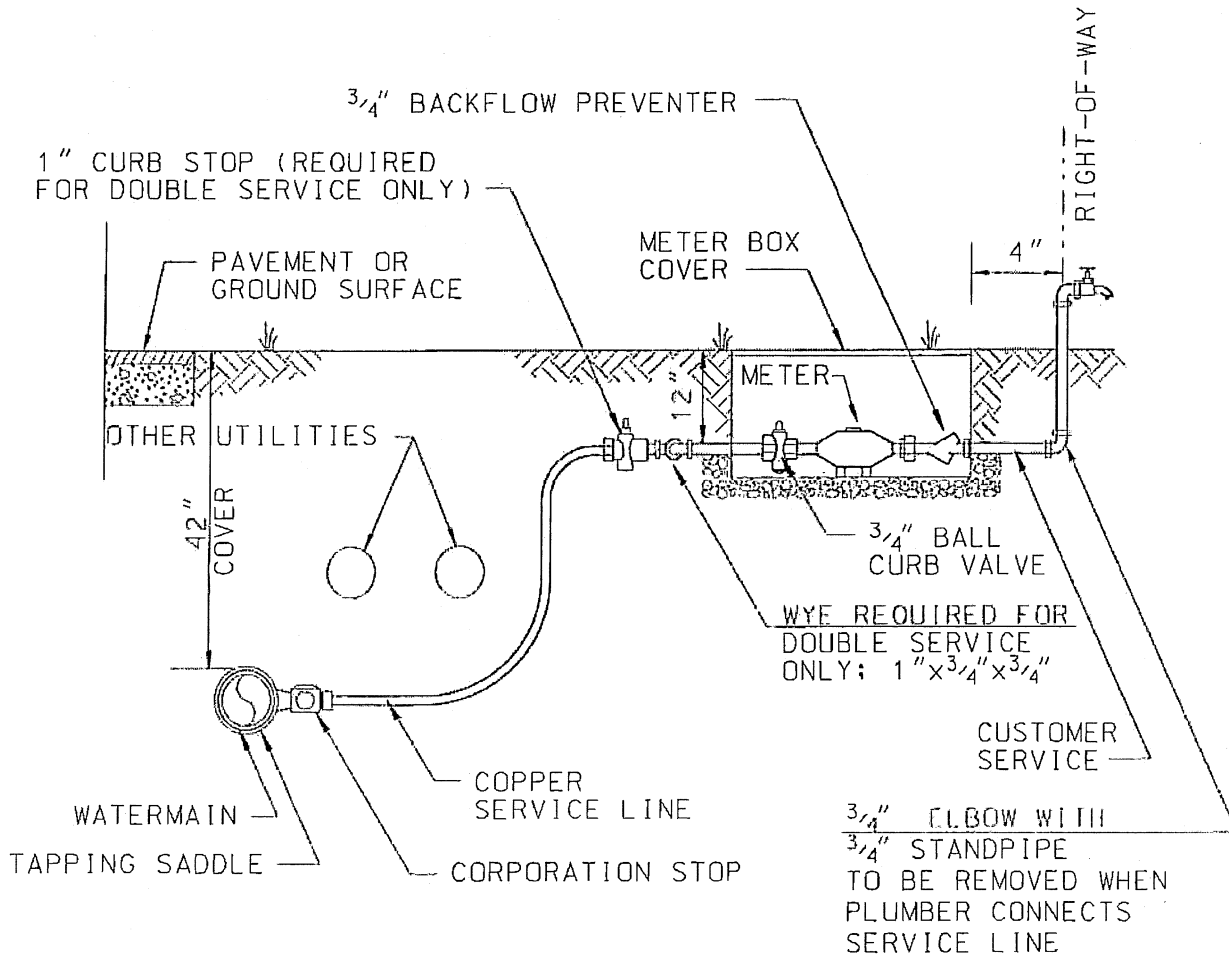

NOTE:

1. FITTINGS TO METER TO BE FLARED FITTINGS. PAST METER TO BE THREADED.
2. DOUBLE SERVICE NOT ALLOWED ABOVE ELEVATION 1140.

DESCRIPTION	SINGLE SERVICE	DOUBLE SERVICE
METER	3/4"	(2) - 3/4"
CORPORATION STOP	3/4"	1"
COPPER SERVICE LINE	3/4"	1"
CURB STOP	3/4"	1" (2) 3/4"
DOUBLE STRAP TAPPING SADDLE	3/4"	1"
BALL CURB STOP	3/4"	(2) 3/4"



City of Opportunity. Moving Forward!

DETAIL 2713-14B 1" WATER METER INSTALLATION (TYPICAL SECTION)

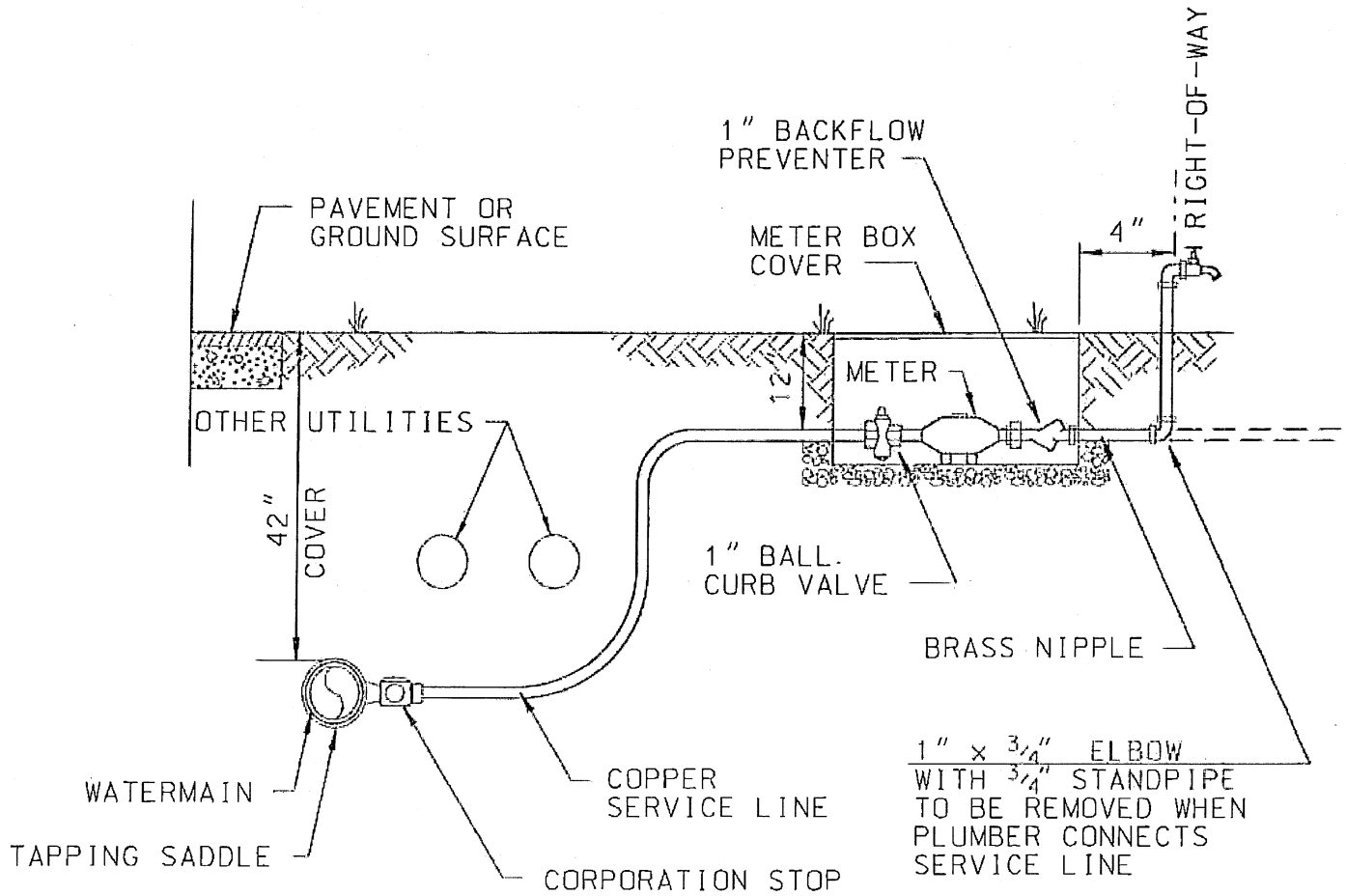

NOTE: FITTINGS TO METER TO BE FLARED
FITTINGS PAST METER TO BE THREADED



City of Opportunity. Moving Forward!

DETAIL 2713-14C 3/4" AND 1" WATER METER BOX AND LID DETAIL

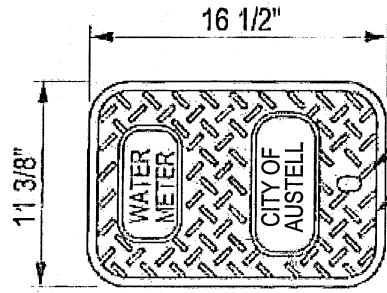

TOP VIEW

METER BOX LID

1" LIFT HOLE
CAST IRON LID

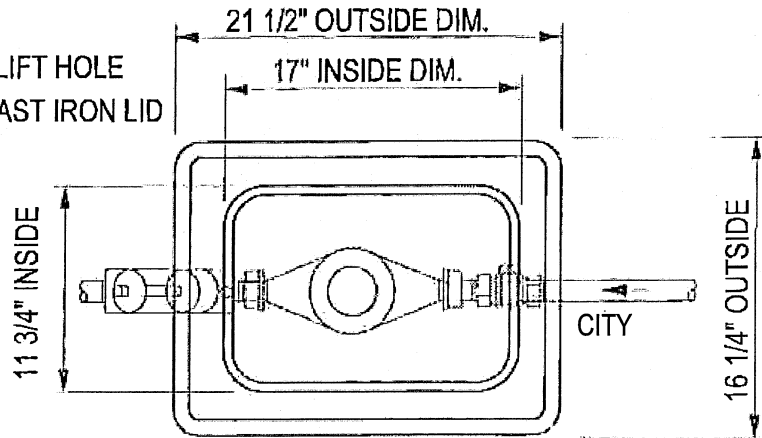

TOP VIEW

METER BOX

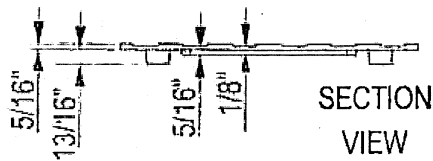

SECTION
VIEW

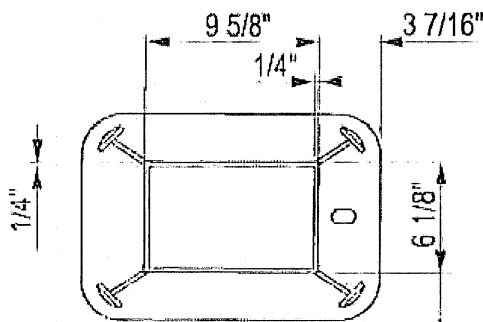

BOTTOM
VIEW

METER BOX

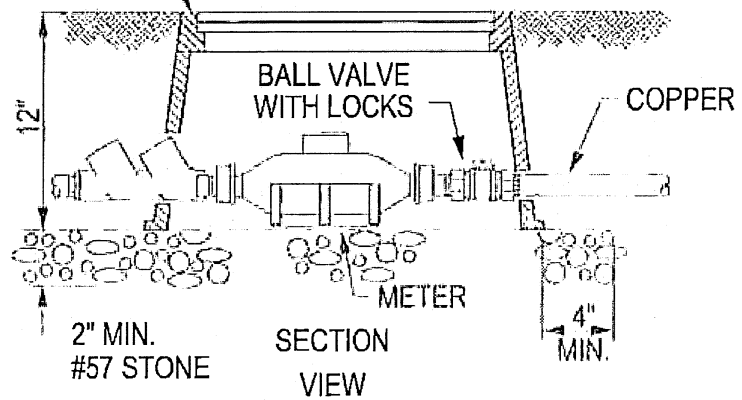

SECTION
VIEW

TYPICAL INSTALLATION

NOTE:

1. METER BOX LID TO BE CAST IRON - (VESTAL MFG. CO. OR APPROVED EQUIVALENT).
2. METER BOX TO BE NDS D1200 OR APPROVED EQUIVALENT.



City of Opportunity. Moving Forward!

DETAIL 2713-23 3/4" THROUGH 10" WATER METER INSTALLATION INFORMATION

METER SIZE & TYPE IN INCHES	RESIDENTIAL	COMMERCIAL	IRRIGATION ONLY (STANDARD)	DOMESTIC	COMBINED IRR. & DOM.	FIRE PROTECTION	SIZE OF METER BOX IN INCHES (OUTSIDE DIM.) W x L x D	SIZE OF METER VAULT IN FEET (OUTSIDE DIM.) W x L x D	CCWS VAULT I.D.	REQUIRED EASEMENT IN FEET W x L
3/4 x 3/4 *	X		X	X	X		14 x 20 1/4 x 18		#1	NONE
3/4 x 3/4		X	X				14 x 20 1/4 x 18		#1	5 1/2 x 4
1 *	X		X	X	X		14 x 20 1/4 x 18		#1	NONE
1		X	X	X	X		14 x 20 1/4 x 18		#1	5 1/2 x 4
1 1/2		X	X	X	X		24 x 36 x 18		#2	5 x 6
1 1/2 wBP		X	X	X	X		24 x 36 x 18		#2	5 x 6
2		X	X	X	X		24 x 36 x 18		#2	5 x 6
2 w2BP		X		X	X		24 x 36 x 18		#2	5 x 6
3 w2BP		X		X	X			5 x 8 x 5 1/2	A	9 x 10
4 w2BP		X		X	X			5 x 8 x 5 1/2	A	9 x 10
6 DC		X				X		5 x 8 x 5 1/2	A	9 x 10
6 FM x 1.5 or 2		X		X	X	X		7 x 13 x 5 1/2	B	11 x 15
8 DC		X				X		5 x 8 x 5 1/2	A	9 x 10
8 FM x 2		X		X	X	X		7 x 13 x 5 1/2	B	11 x 15
10 DC		X				X		5 x 9 1/2 x 5 1/2	C	9 x 11 1/2
10 FM x 2		X		X	X	X		11 x 15 x 5 1/2	D	15 x 17

w2BP _____ WITH 2" BYPASS LINE
 DC _____ DOUBLE CHECK VALVE ASSEMBLY WITH NO BYPASS LINE (FIRE PROTECTION ONLY)
 6FM x 1.5 or 2 ... FIRELINE AND MASTER METER - 6" SIZE OF FIRE LINE METER,
 1.5" or 2" "SIZE OF LOW FLOW METER.
 ALL FM METERS INCLUDE 6" BYPASS LINE.

CCWS ID

- #1 _____ STANDARD 12" x 17" METER BOX
- #2 _____ STANDARD 24" x 36" METER BOX
- A _____ 4'-0" x 7'-0" x 5'-0" CONCRETE VAULT WITH LID. HATCH 3'-0" x 3'-0" x 0'- 1/4" REC.
- B _____ 6'-0" x 12'-0" x 5'-0" CONCRETE VAULT WITH LID. HATCH 3'-0" x 3'-0" x 0'- 1/4" REC.
- C _____ 4'-0" x 8'-6" x 5'-0" CONCRETE VAULT WITH LID. HATCH 3'-0" x 3'-0" x 0'- 1/4" REC.
- D _____ 10'-0" x 14'-0" x 5'-0" CONCRETE VAULT WITH LID. HATCH 4'-0" x 4'-0" x 0'- 1/4" REC.

REQUIRED EASEMENT 5 1/2 x 4 5 1/2 EQUALS FOOTAGE ALONG RIGHT OF WAY;
 4 EQUALS FOOTAGE PERPENDICULAR TO RIGHT OF WAY.

* CCWS WILL PROVIDE 3/4" AND 1" BACKFLOW DEVICES TO BE INSTALLED WITH RESIDENTIAL 3/4" AND 1" METER INSTALLATIONS.



City of Opportunity. Moving Forward!

DETAIL 2713-30 WATER MAIN IN STREET INSTALLATION

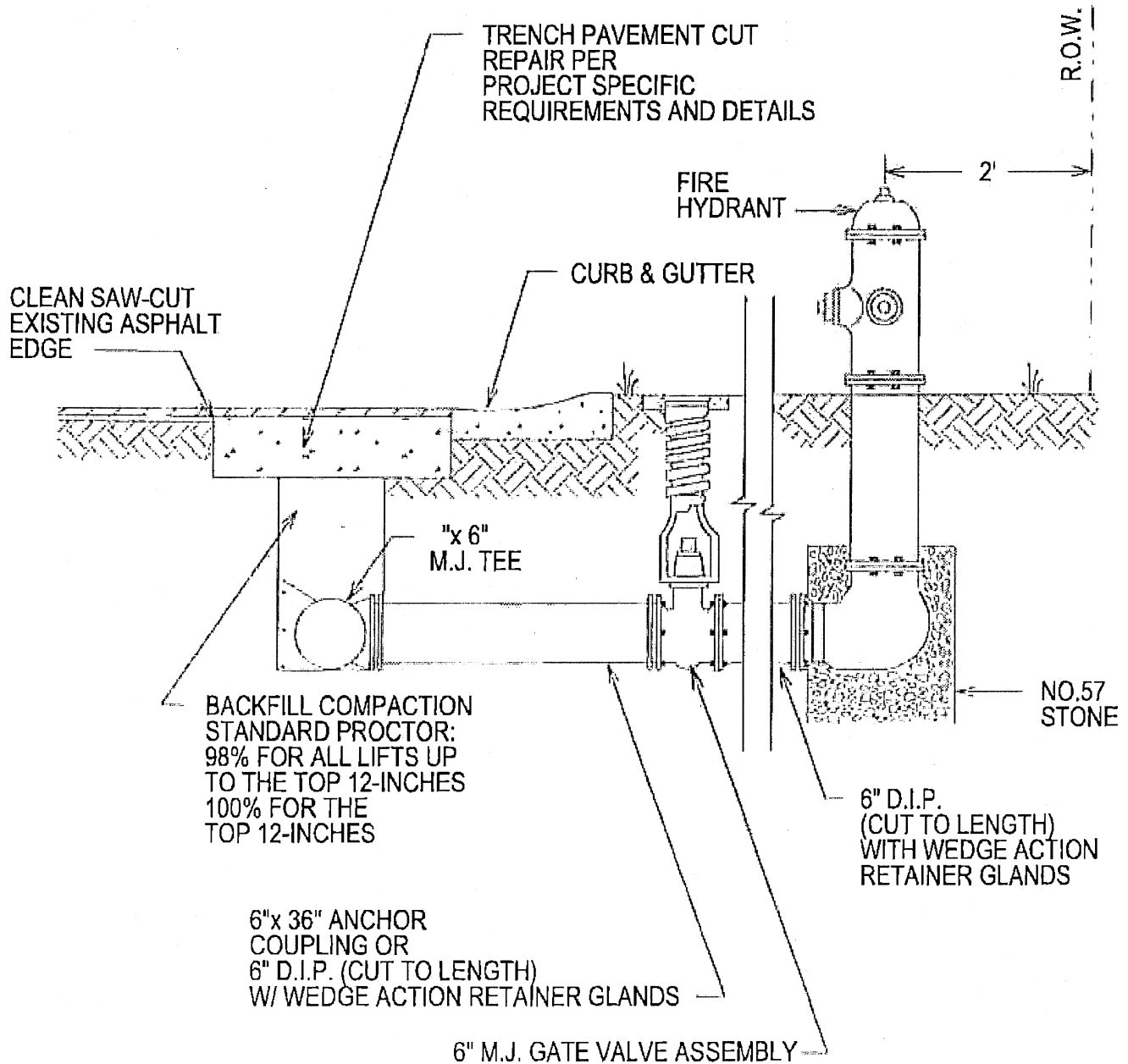



City of Opportunity. Moving Forward!

DETAIL 2713-31 WATER MAIN IN STREET INSTALLATION

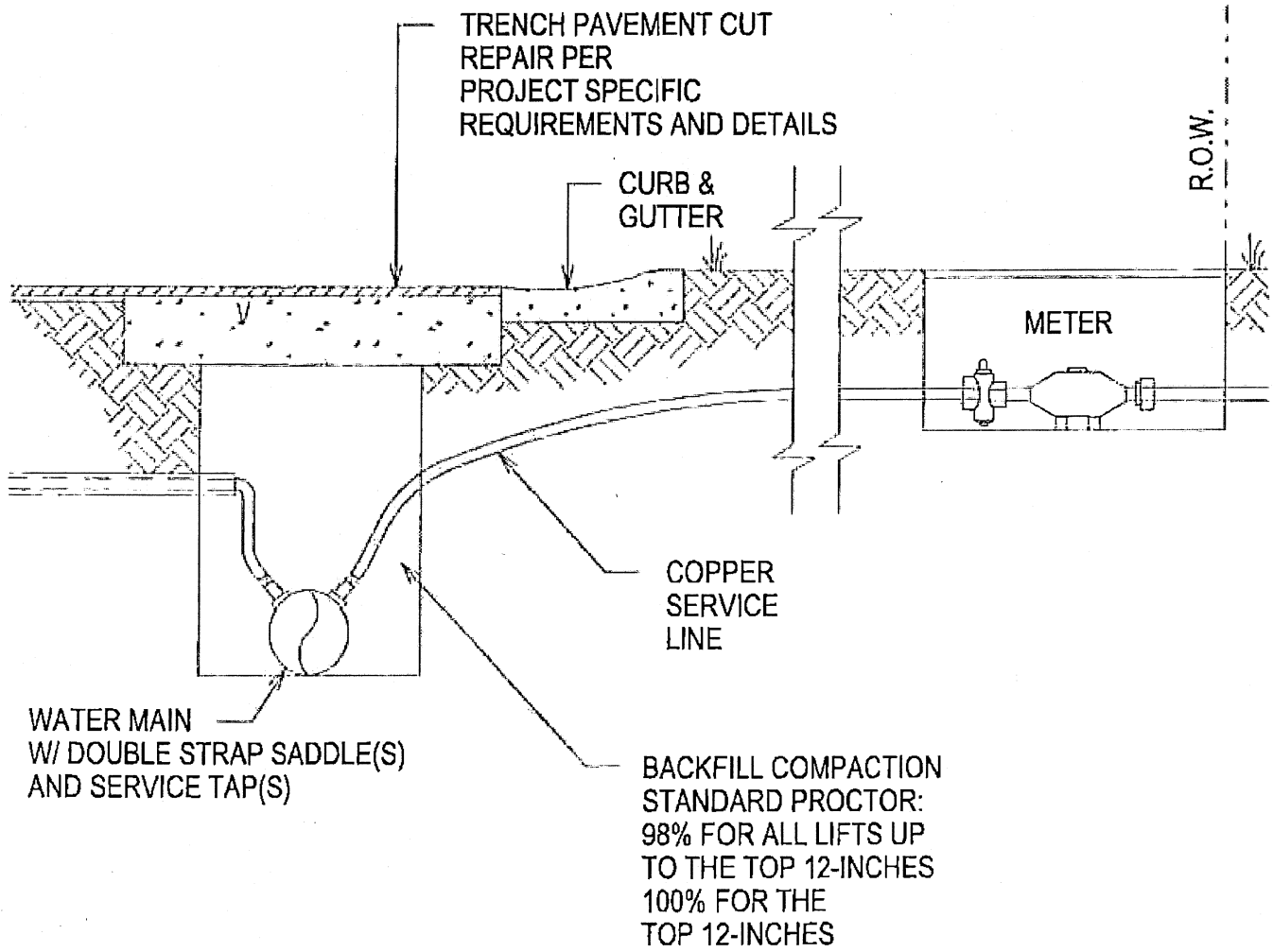



City of Opportunity. Moving Forward!

DETAIL 2713-32 VALVE RAISING OUT OF PAVEMENT

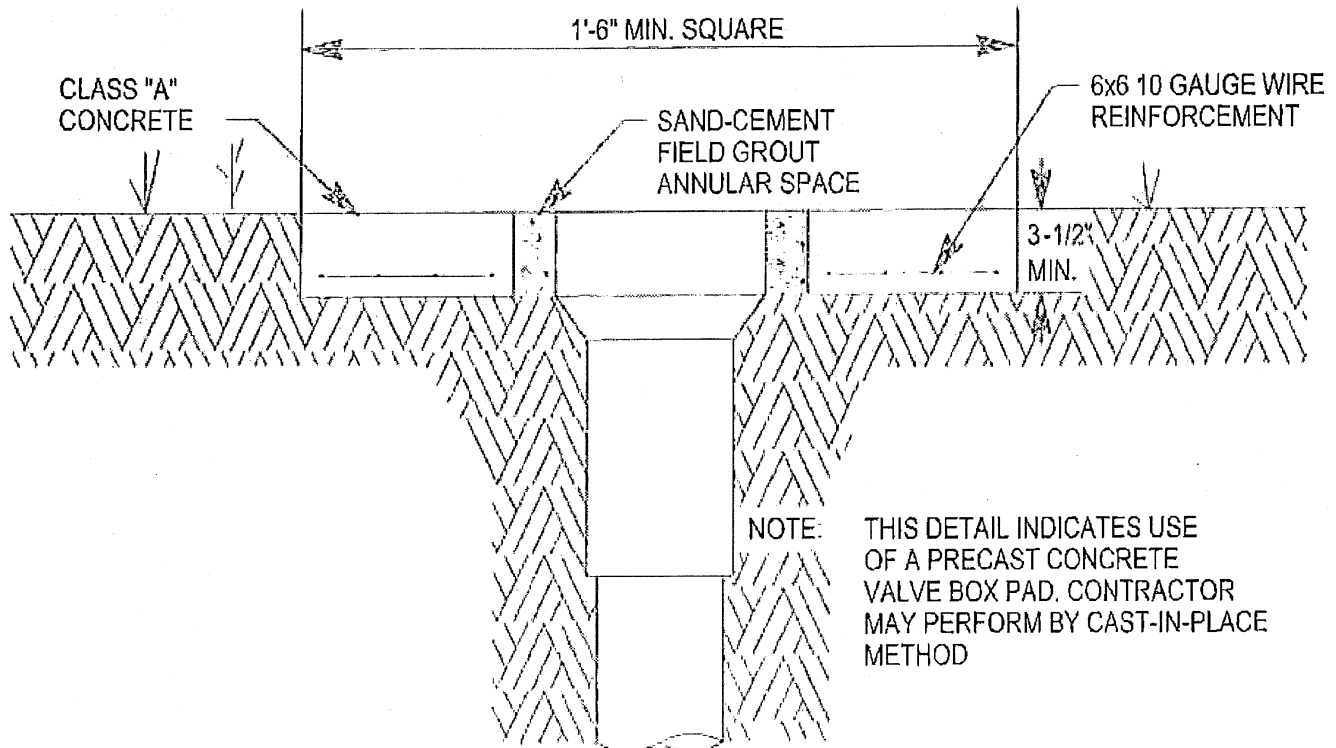

GENERAL NOTES

1. IF REPLACEMENT IS NECESSARY, VALVE BOX SHALL BE APPROVED STANDARD CAST IRON ADJUSTABLE WITH A MIN. DIA. OF 5 -1/4". THE CASTING SHALL BE COATED WITH COAL-TAR PITCH VARNISH. THE LID SHALL BEAR THE WORD "WATER" OR THE LETTER "W". BOXES SHALL BE EQUAL TO VULCAN PATTERN VVB-4. NO EXISTING VALVE BOX SHALL BE REUSED IF CRACKED, OR OTHERWISE DAMAGED, OR IF FOUND INAPPROPRIATE FOR SERVICE IN THE LOCATION.
2. VALVE BOX SHALL BE CLEANED OF ANY EXISTING DEBRIS, DIRT, SILT, GRAVEL, ETC. AND/OR STRAIGHTENED TO ENSURE POSITIVE ACCESSIBILITY OF THE VALVE OPERATING NUT OR HANDWHEEL.



City of Opportunity. Moving Forward!

DETAIL 2713-33 VALVE RAISING IN STREET AFTER REPAVING

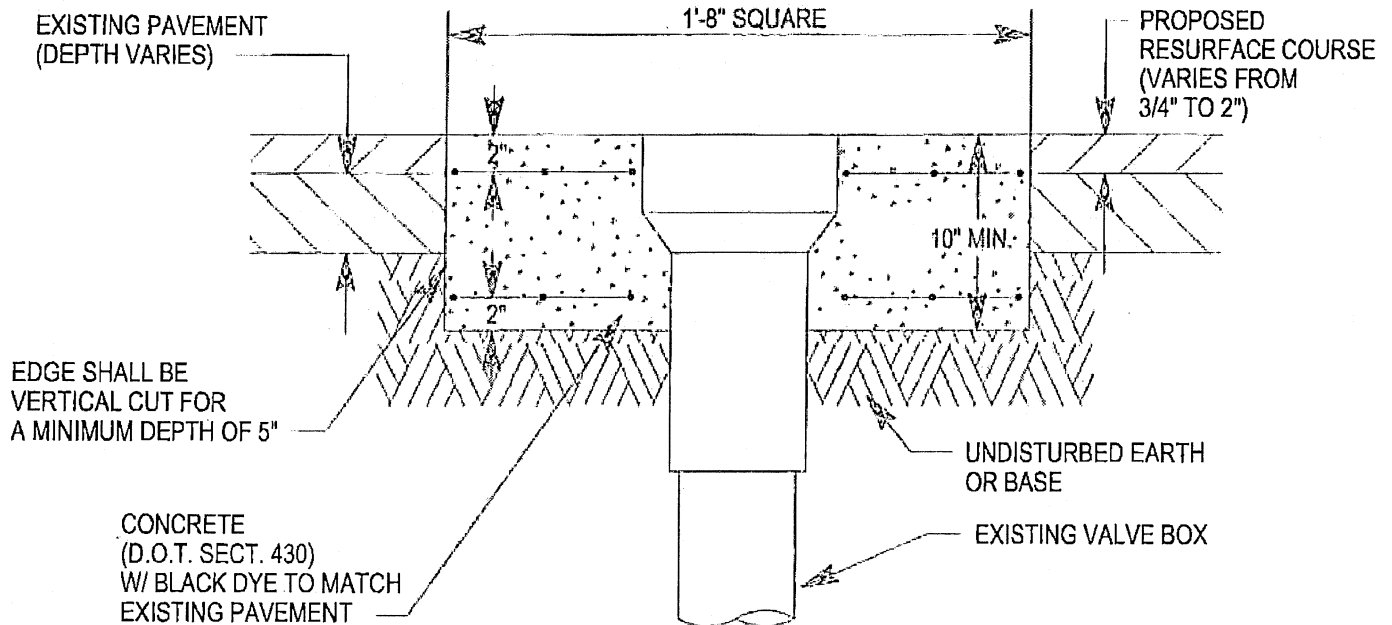

NOTES:

CONCRETE FOR COLLAR SHALL BE A MINIMUM OF 10" DEEP OR FROM THE TOP OF THE VALVE BOX, FLUSH WITH THE NEWLY RESURFACED PAVEMENT, TO UNDISTURBED EARTH.

REINFORCEMENT SHALL BE CUT-TO-FIT MAT OF 6"x 6", 10x10 GAUGE WELDED WIRE FABRIC

GENERAL NOTES

1. IF REPLACEMENT IS NECESSARY, VALVE BOX SHALL BE APPROVED STANDARD CAST IRON ADJUSTABLE WITH A MIN. DIA. OF 5 1/4" THE CASTING SHALL BE COATED WITH COAL-TAR PITCH VARNISH. THE LID SHALL BEAR THE WORD "WATER" OR THE LETTER "W". BOXES SHALL BE EQUAL TO VULCAN PATTERN V V B-4. NO EXISTING VALVE BOX SHALL BE REUSED IF CRACKED, OR OTHERWISE DAMAGED, OR IF FOUND INAPPROPRIATE FOR SERVICE IN THE LOCATION.

2. VALVE BOX SHALL BE CLEANED OF ANY EXISTING DEBRIS, DIRT, SILT, GRAVEL, ETC AND/OR STRAIGHTENED TO ENSURE POSITIVE ACCESSIBILITY OF THE VALVE OPERATING NUT OR HANDWHEEL.



City of Opportunity. Moving Forward!

DETAIL 2713-42 NEW DOMESTIC/IRRIGATION COMBINATION METER WITH BACK FLOW PREVENTION DEVICE INSTALLATION DEVELOPER INSTALLED

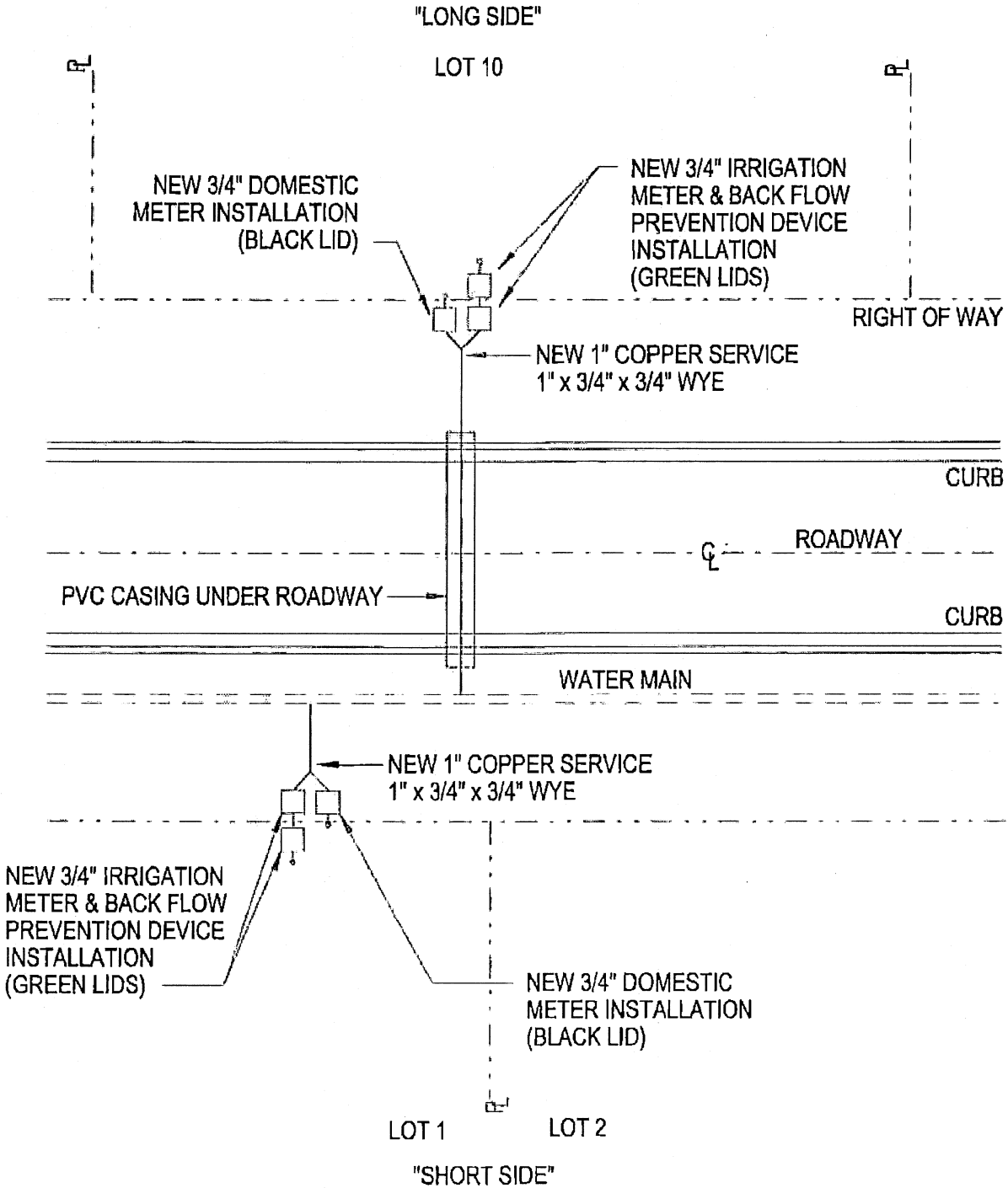

NOTE: DOUBLE SERVICES FOR DOMESTIC NOT ALLOWED WITH IRRIGATION METERS.



City of Opportunity. Moving Forward!

DETAIL 2713-50 ILLUSTRATION OF TYPICAL WATER SUPPLY

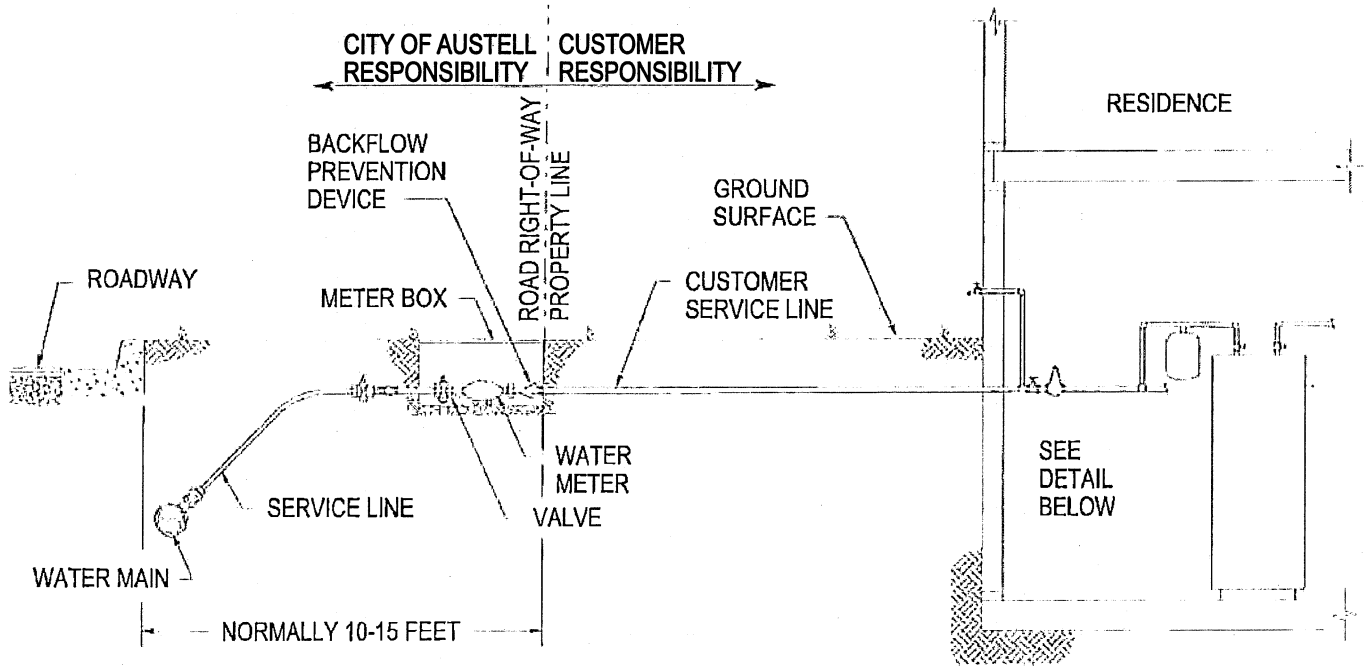

DETAIL

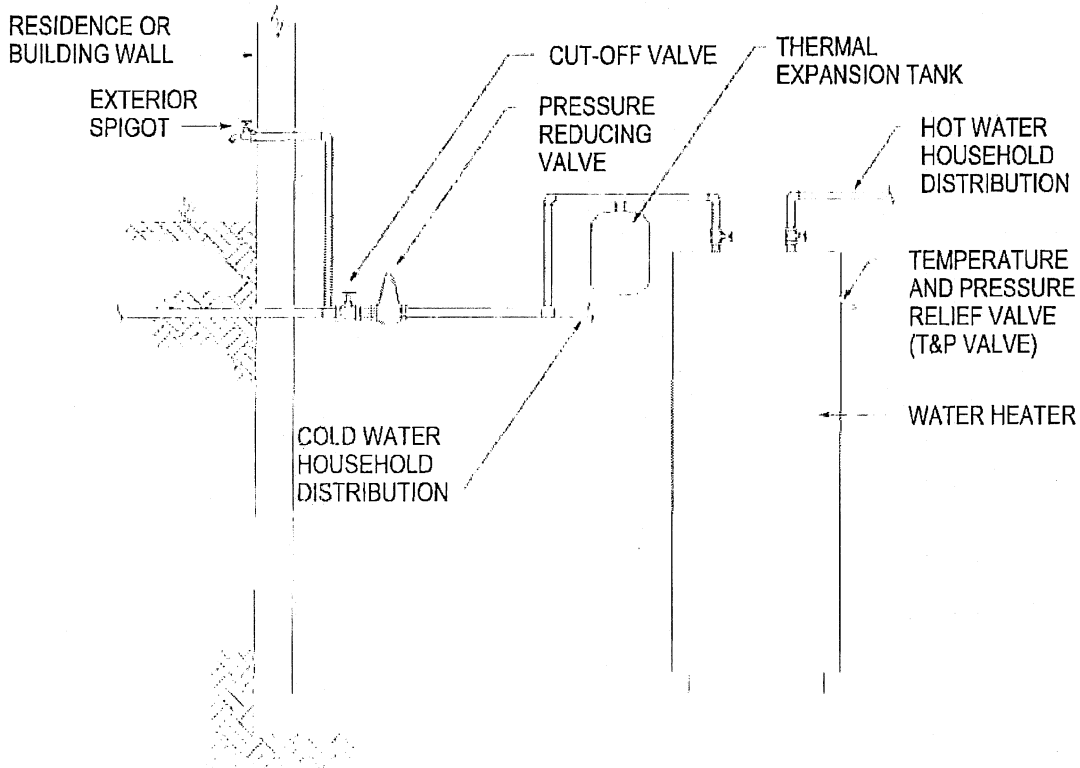



City of Opportunity. Moving Forward!

DETAIL 2722-1 SEWER TRENCH DETAIL

BACKFILL COMPACTION (STANDARD PROCTOR)

- A. UNPAVED AREAS OUTSIDE OF ROADWAY RIGHT-OF-WAYS:
90% FOR ALL LIFTS
- B. UNPAVED AREAS OF ROADWAY RIGHT-OF-WAY: 98% FOR ALL LIFTS
- C. PAVED AREAS: 98% FOR ALL LIFTS UP TO THE TOP 12-INCHES,
100% FOR THE TOP 12-INCHES

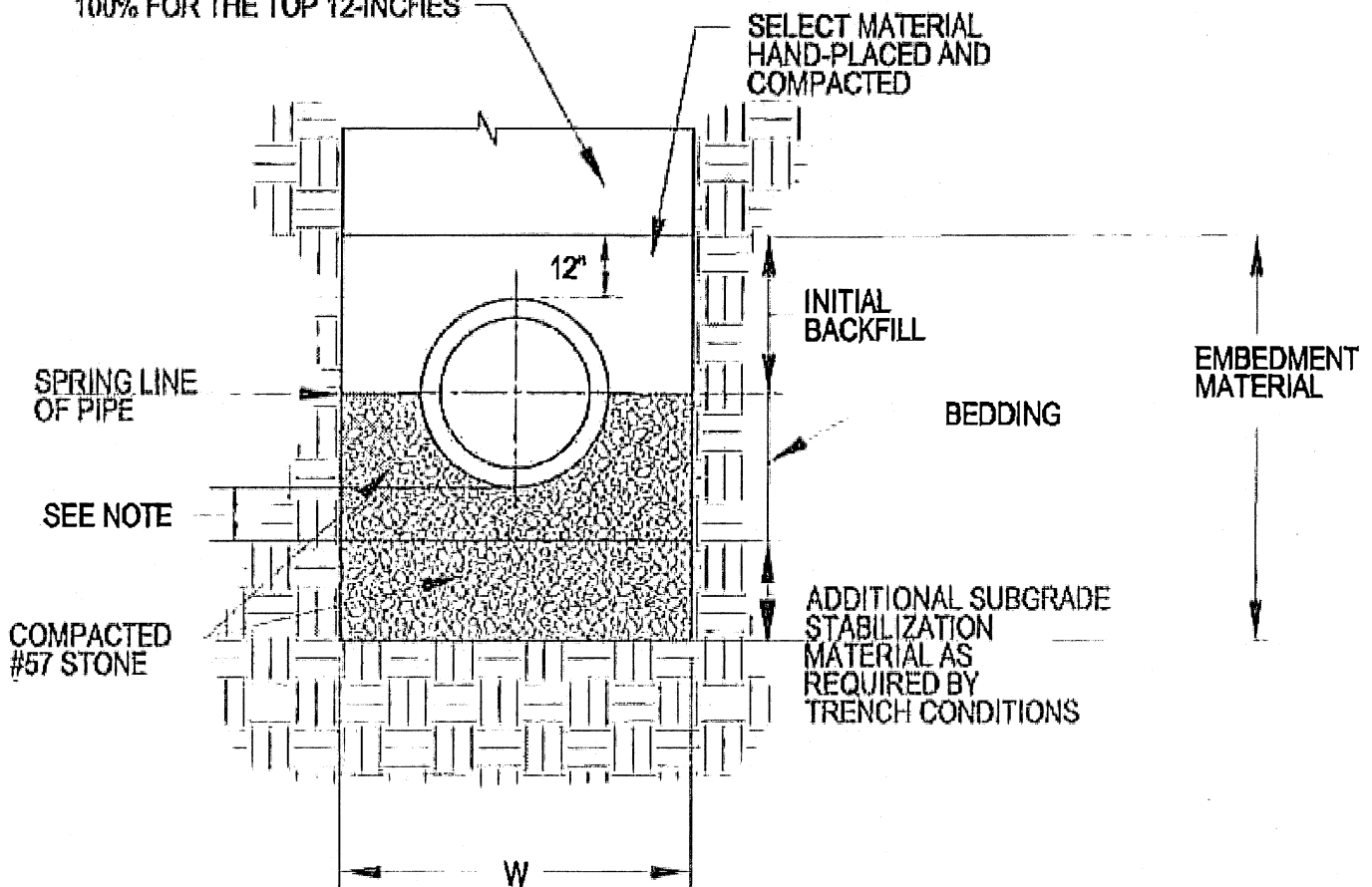

**W = TRENCH WIDTH DEFINED AS NOMINAL PIPE
OUTSIDE DIAMETER PLUS TWO FEET FOR MEASUREMENT
AND PAYMENT OF ADDITIONAL SUBGRADE STABILIZATION
MATERIAL ALLOWANCE AND/OR ROCK EXCAVATION
ALLOWANCE (AS APPLICABLE AND AS AUTHORIZED)**

**NOTE:
BEDDING DEPTH BELOW PIPE TO BE AS FOLLOWS:
SERVICE LATERALS = 4" MINIMUM
SEWERS - 8" DIA. TO 18" DIA. = 6" MINIMUM
SEWERS - GREATER THAN 18" DIA. = PIPE DIA./3**



City of Opportunity. Moving Forward!

DETAIL 2722-2 SEWER SERVICE CONNECTION

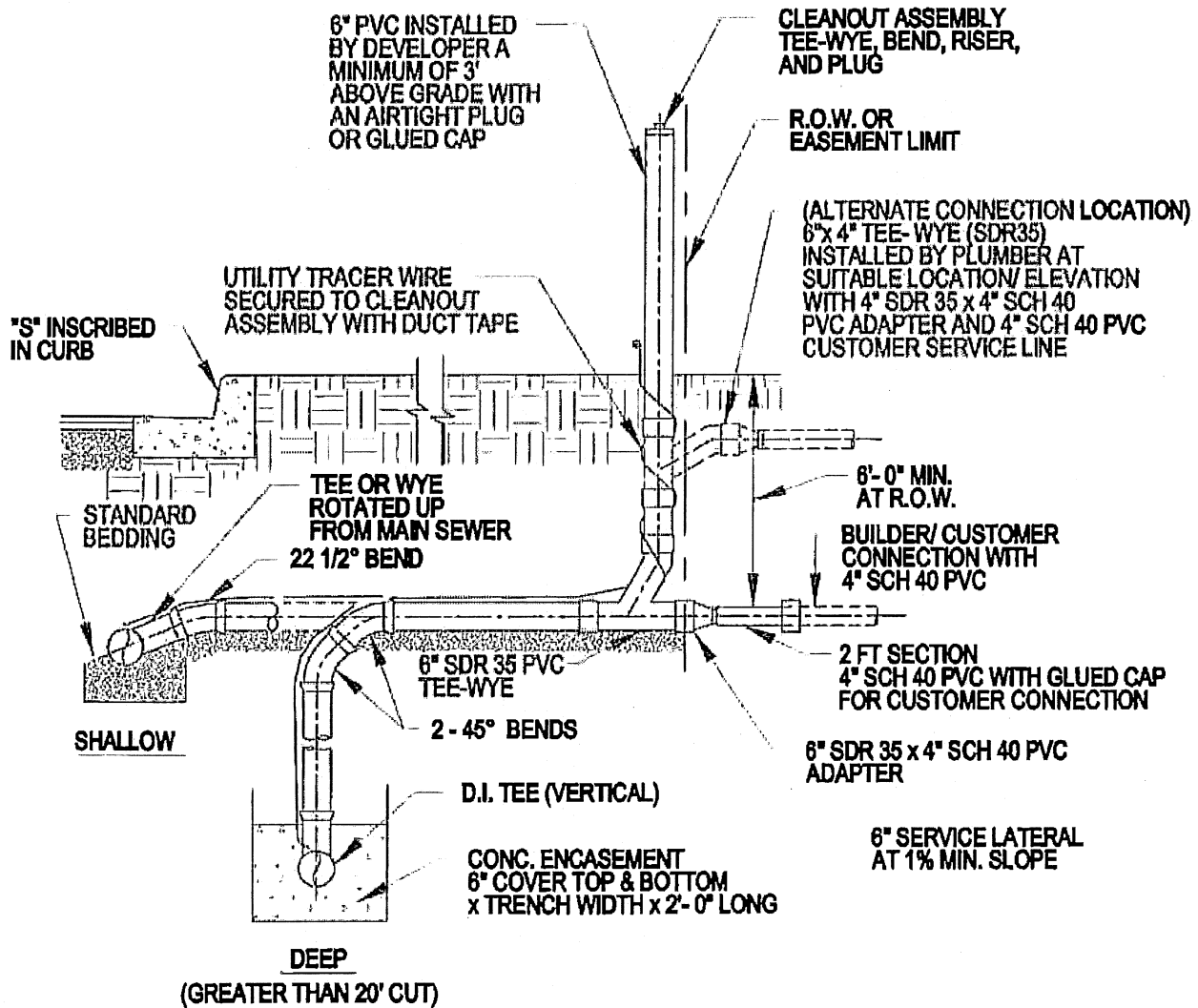

6" CLEANOUT ASSEMBLY ADJUSTED TO LANDSCAPE GRADE BY BUILDER AT TIME OF CONNECTION

15" DIA. CAST IRON RING AND COVER (VESTAL RMC-15-H, OR EAST JORDAN IRON WORKS V-8502 OR EQUAL)

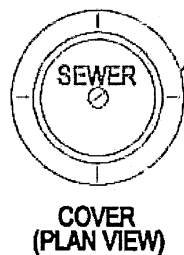
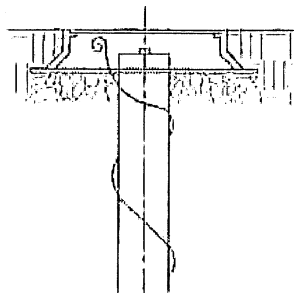

NOTES:

- 1. UTILITY TRACER SYSTEM REQUIRED REFER TO DETAIL 02722-4B**
- 2. ONLY 1 SINGLE FAMILY RESIDENCE PER SEWER SERVICE CONNECTION**
- 3. SERVICE LATERAL BEDDING & BACKFILL TO CONFORM TO DETAIL 02722-1, EXCEPT BEDDING DEPTH UNDER PIPE TO BE 4" MIN.**



City of Opportunity. Moving Forward!

DETAIL 2722-3 DRY SEWER

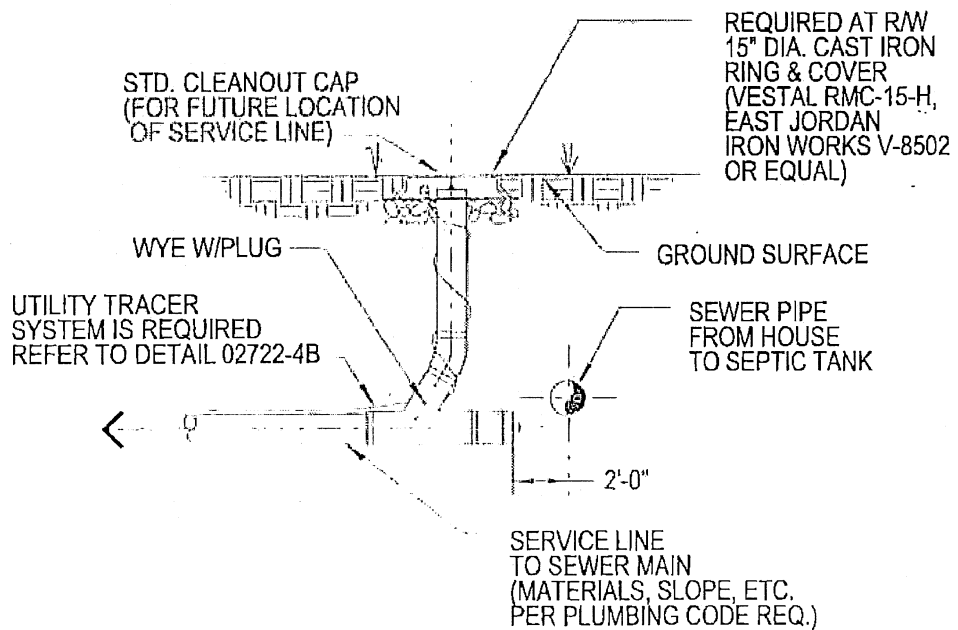
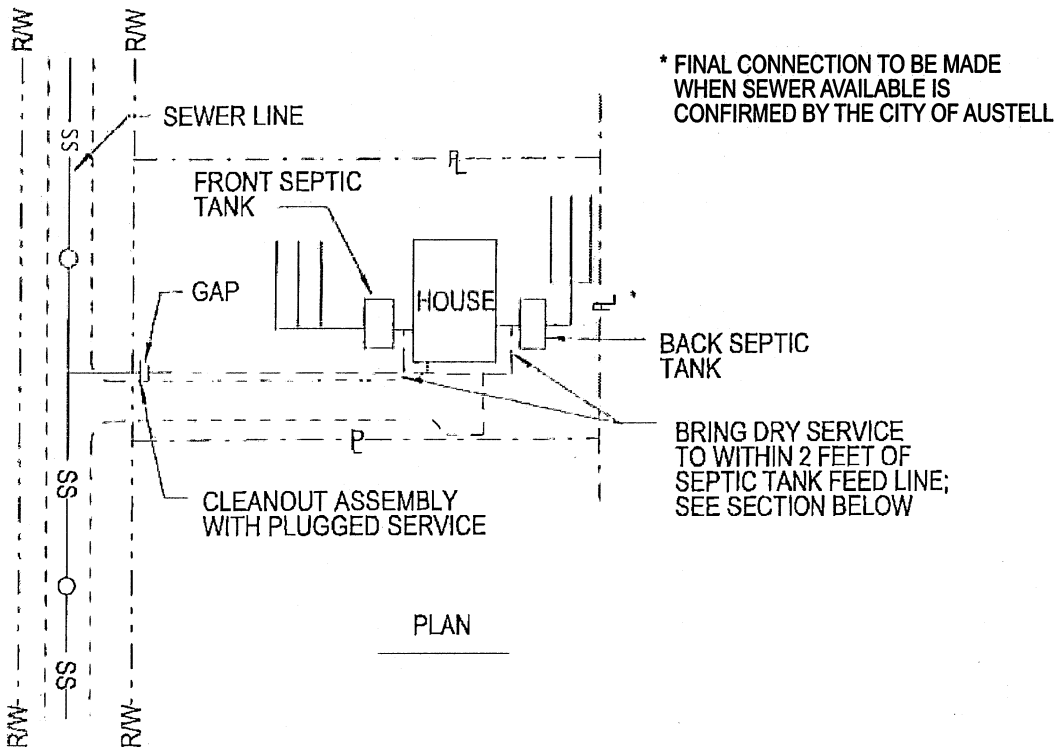



City of Opportunity. Moving Forward!

DETAIL 2722-4A UTILITY TRACER

POLYETHYLENE, 6 MILS. MINIMUM THICKNESS,
6" WIDE, GREEN WARNING TAPE
MARKED "SEWER LINE BURIED BELOW"

CONTINUOUS
INSULATED 12 Ga.
SOLID COPPER
TRACER WIRE
PLACED IN INITIAL
BACKFILL

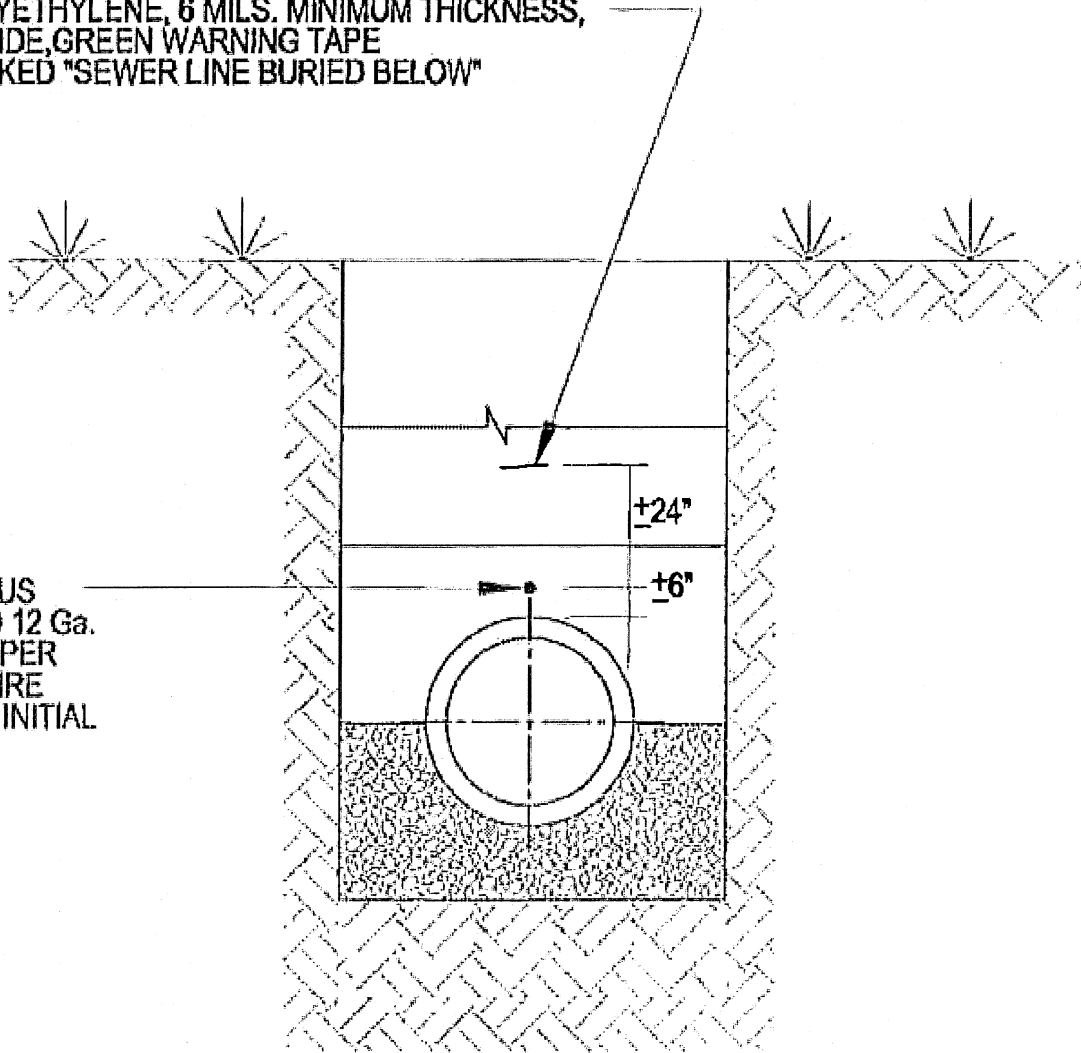

NOTES:

1. TRACER WIRE TO BE 12 AWG SOLID COPPER RATED FOR DIRECT BURY WITH MINIMUM 30 MIL POLYETHYLENE INSULATION.
2. ALL SPLICES AND CONNECTIONS SHALL BE PROTECTED WITH DIRECT BURY CONNECTORS EQUAL TO 3M DBR/Y-6 SPLICE KITS
3. TRACER WIRE TO CONTINUE UNINTERRUPTED AROUND MANHOLES



City of Opportunity. Moving Forward!

DETAIL 2722-4B SEWER SERVICE UTILITY TRACER

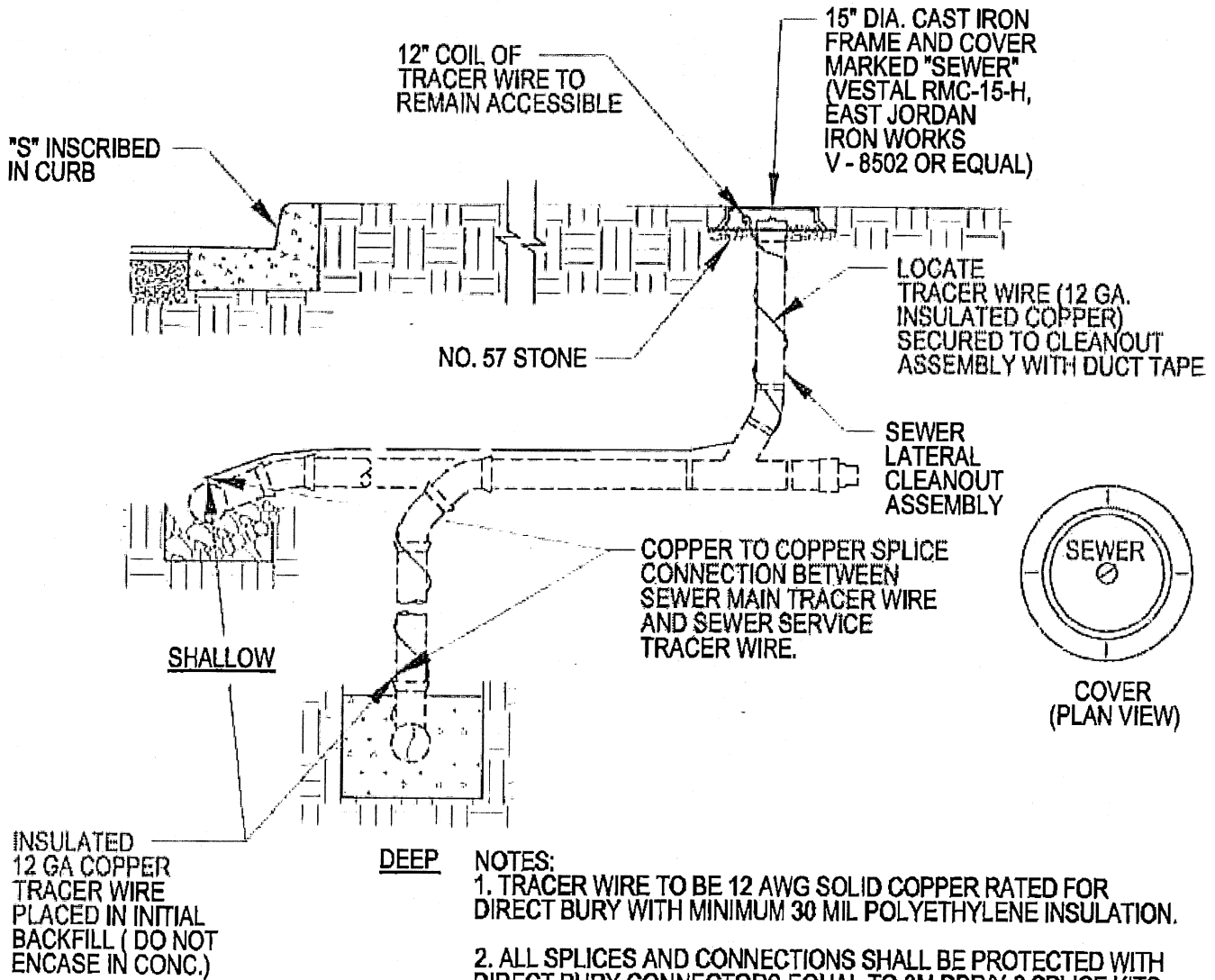

NOTES:

1. TRACER WIRE TO BE 12 AWG SOLID COPPER RATED FOR DIRECT BURY WITH MINIMUM 30 MIL POLYETHYLENE INSULATION.
2. ALL SPLICES AND CONNECTIONS SHALL BE PROTECTED WITH DIRECT BURY CONNECTORS EQUAL TO 3M DBRY-6 SPLICE KITS
3. TRACER WIRE INSTALLATION SIMILAR AT SERVICE STUB-OUTS FROM MANHOLES



City of Opportunity. Moving Forward!

DETAIL 2722-4C FORCE MAIN MARKER

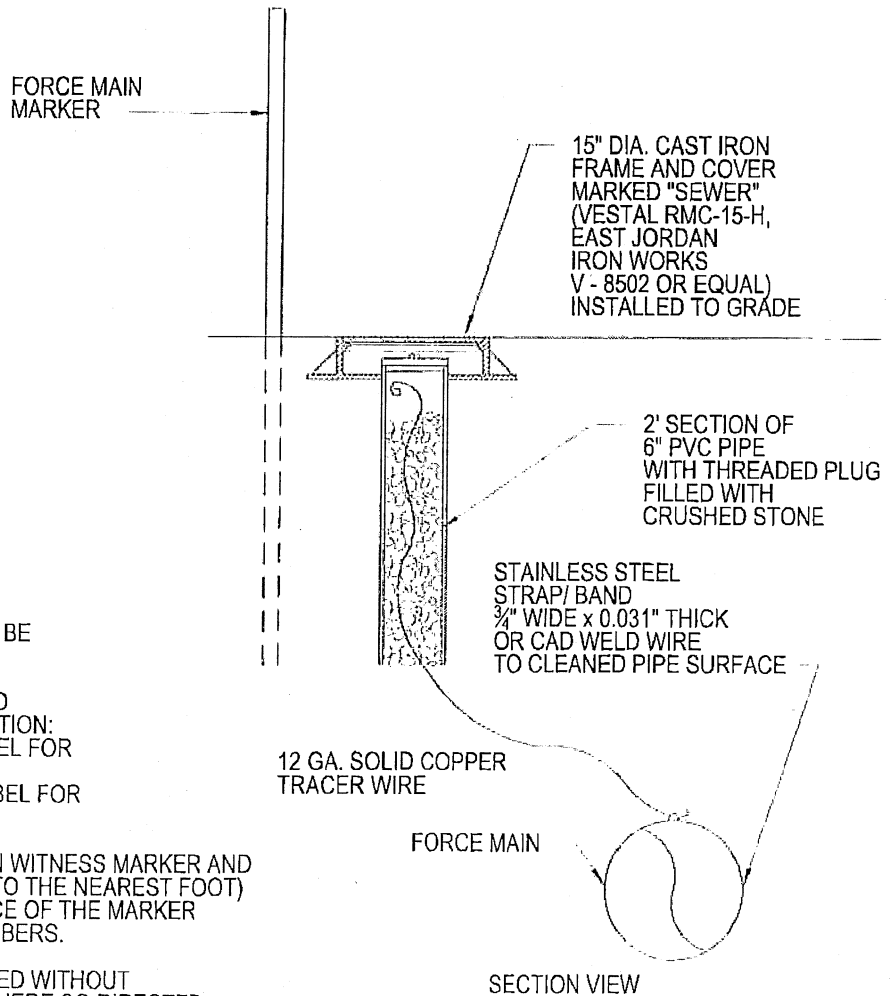
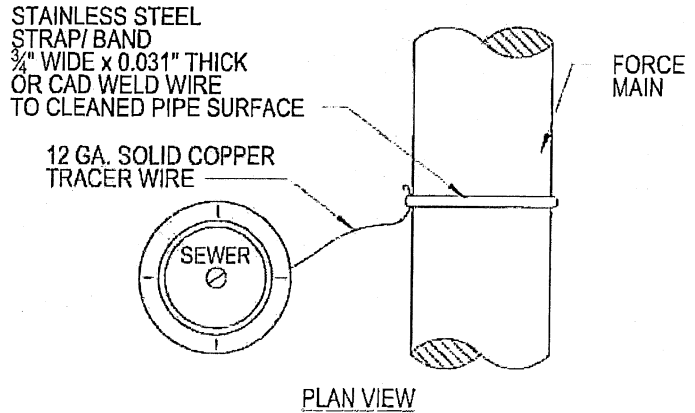
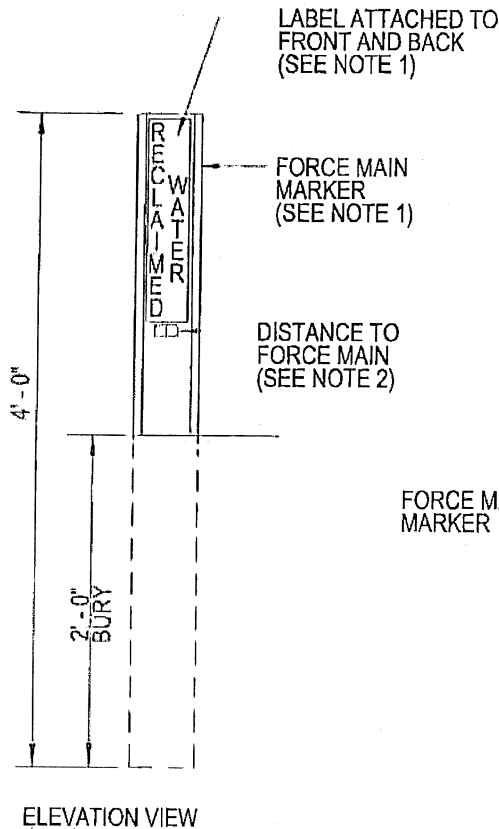

NOTES:

1. FORCE MAIN WITNESS MARKERS SHALL BE CARSONITE UTILITY MARKER OR EQUAL, OF COMPOSITE CONSTRUCTION, APPROXIMATELY 4 - INCHES IN WIDTH, AND IN THE FOLLOWING COLORS FOR APPLICATION:
 - WHITE WITH GREEN IDENTIFICATION LABEL FOR SANITARY SEWER FORCE MAINS
 - PURPLE WITH WHITE IDENTIFICATION LABEL FOR RECLAIMED WATER FORCE MAINS

2. THE DISTANCE (HORIZONTAL) BETWEEN WITNESS MARKER AND FORCE MAIN WILL VARY. THE DISTANCE (TO THE NEAREST FOOT) SHALL BE REFERENCED ON THE NEAR FACE OF THE MARKER USING PERMANENT ADHESIVE DECAL NUMBERS.

3. FORCE MAIN MARKERS MAY BE INSTALLED WITHOUT THE UTILITY TRACER WIRE PROVISIONS WHERE SO DIRECTED OR NON-ESSENTIAL



City of Opportunity. Moving Forward!

DETAIL 2722-10 SANITARY SEWER SERVICE CLEAN OUT ASSEMBLY ON AN EXISTING 4" SEWER LINE

PROFILE VIEW

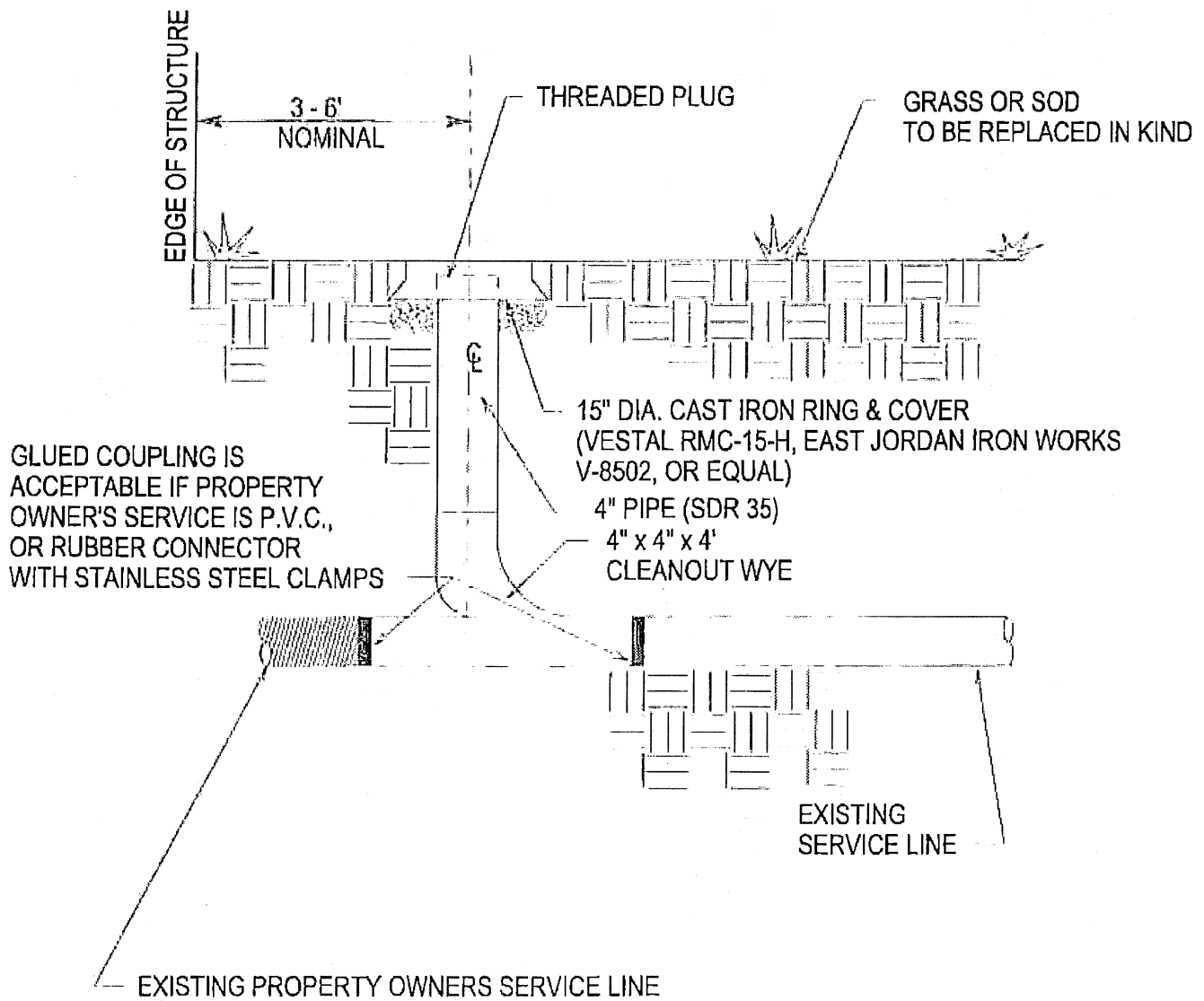



City of Opportunity. Moving Forward!

DETAIL 2722-11 SANITARY SEWER SERVICE CLEAN OUT ASSEMBLY ON AN EXISTING 6" SEWER LINE

PROFILE VIEW

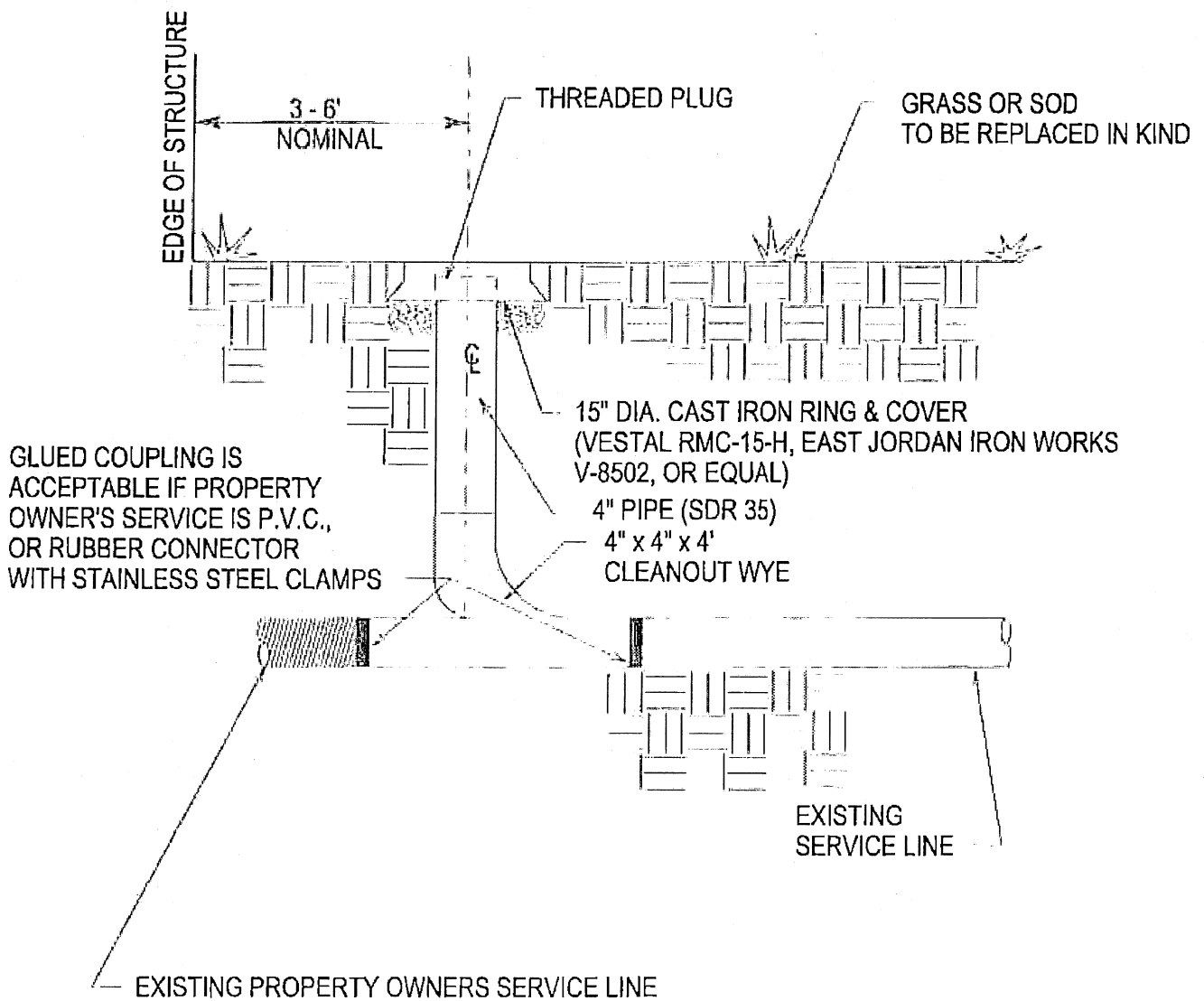



City of Opportunity. Moving Forward!

DETAIL 2722-30 SEWAGE BACKWATER VALVE

BACKWATER VALVE IS REQUIRED WHEN
THE NEXT UPSTREAM MANHOLE COVER IS
HIGHER THAN THE FLOOR LEVEL
WITH PLUMBING FEATURES

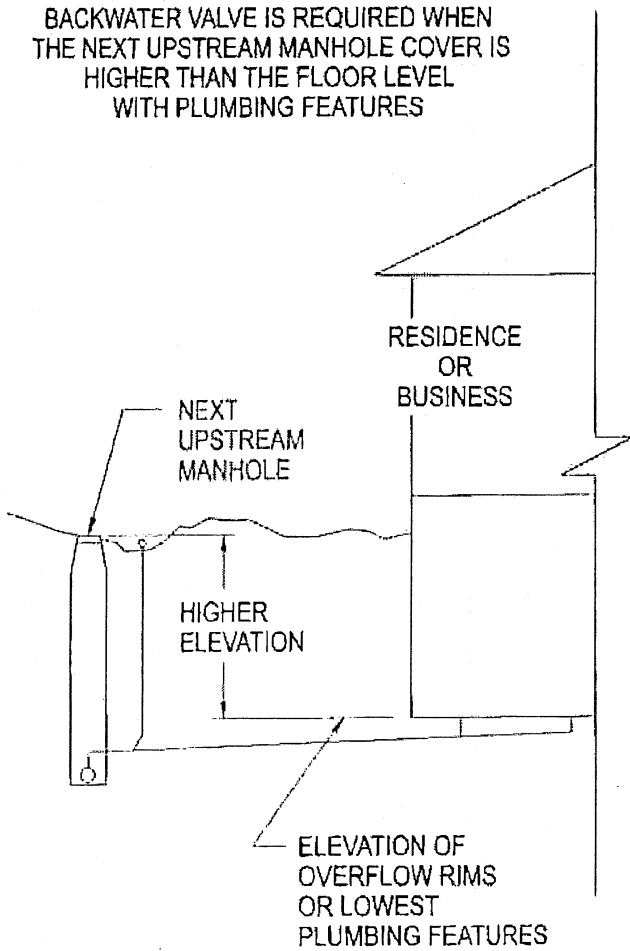

BACKWATER VALVE IS NOT REQUIRED WHEN
THE NEXT UPSTREAM MANHOLE COVER IS
LOWER THAN THE FLOOR LEVEL
WITH PLUMBING FEATURES

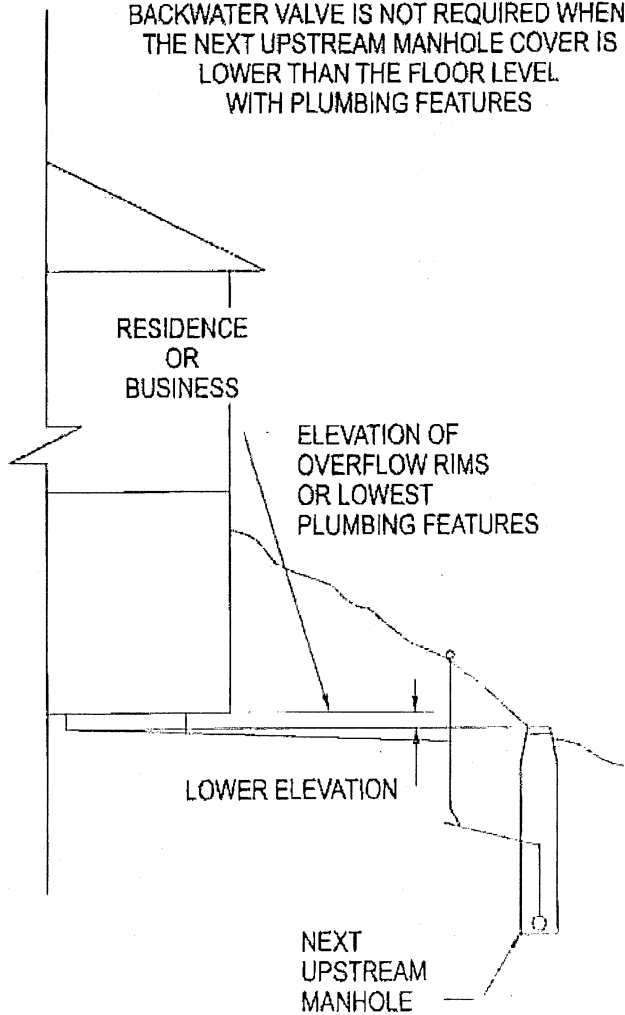



City of Opportunity. Moving Forward!

DETAIL 3410-1 STANDARD MANHOLE (< 20 DEPTH)

PLAN VIEW

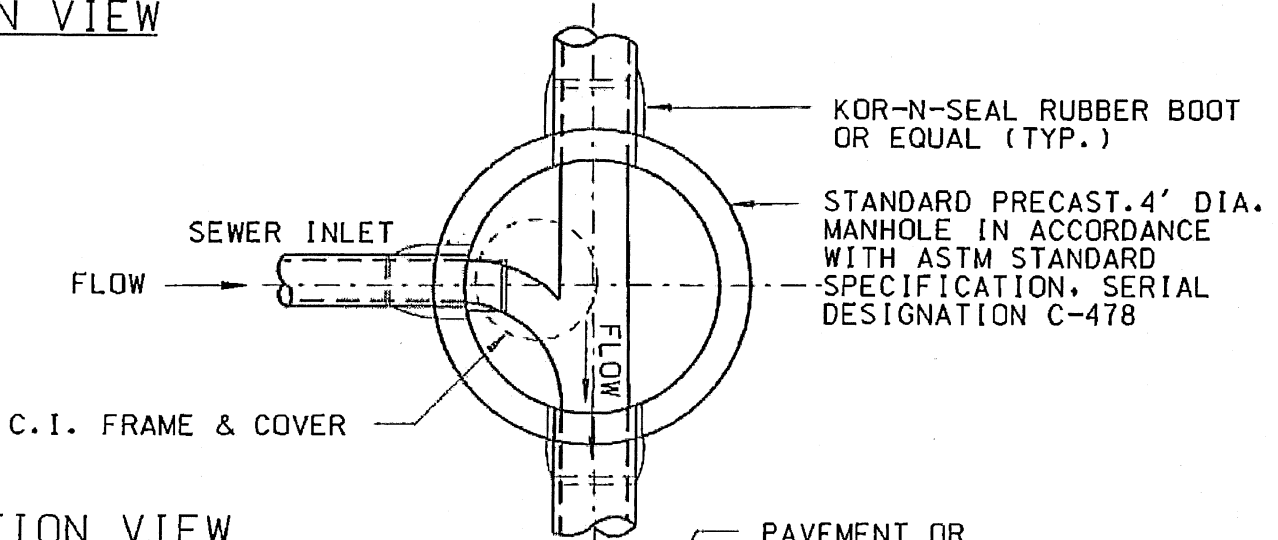

SECTION VIEW

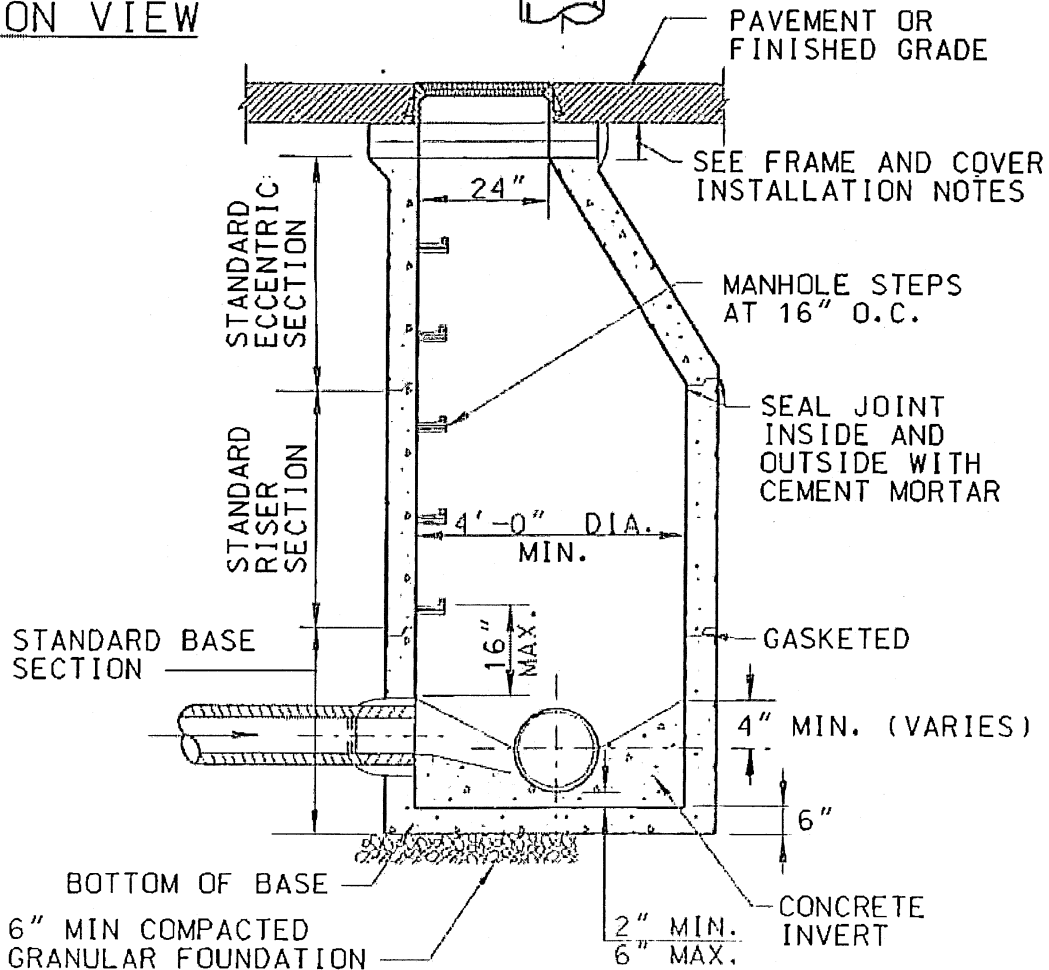



City of Opportunity. Moving Forward!

DETAIL 3410-2 STANDARD MANHOLE FRAME AND COVER INSTALLATION

FRAME AND COVER INSTALLATION NOTES :

1. COVER TO BE SET FLUSH WITH PAVEMENT AND SHALL MATCH SLOPE OF STREET.
2. ADJUSTMENT OF FRAME AND COVER TO GRADE SHALL BE ACOMPLISHED WITH A PRECAST CONCRETE LEVELING RING OR HDPE (LADTECH. INC. OR EQUAL) ADJUSTING RINGS. IN NO CASE SHALL VERTICAL ADJUSTMENT EXCEED 14-INCHES.
3. FRAME SHALL BE IN CEMENT MORTAR BED (1-1/2" THICKNESS).
4. FRAME SHALL BE PRECAST IN CONE SECTION OF ALL MANHOLES NOT LOCATED IN PAVED AREAS.

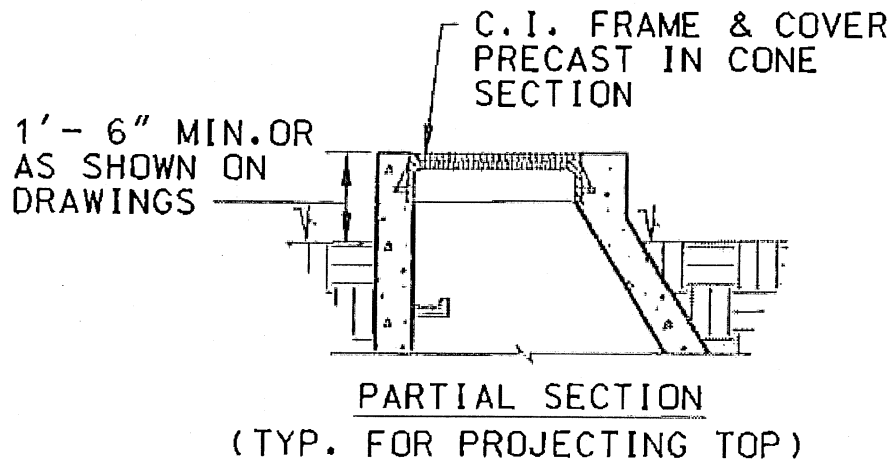



City of Opportunity. Moving Forward!

DETAIL 3410-3 SHALLOW MANHOLE (< 4' TO 6' DEPTH) (SECTION VIEW)

1' - 6" MIN.
OR AS SHOWN
ON PLANS

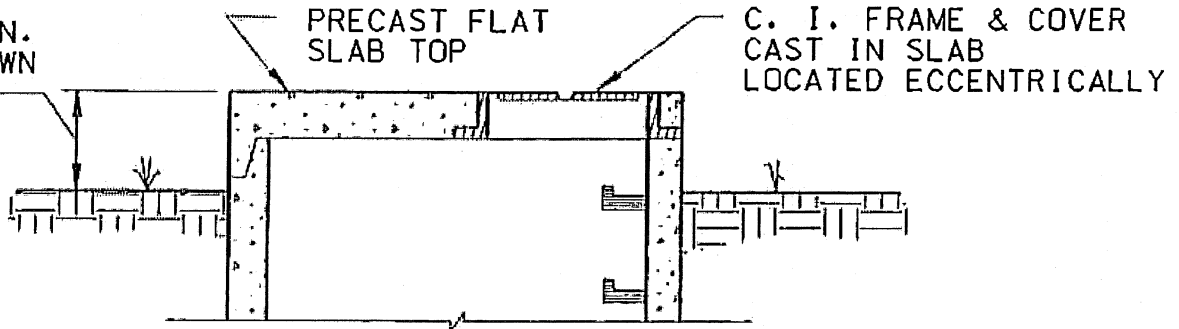

PARTIAL SECTION
(Typical For Projecting Top)

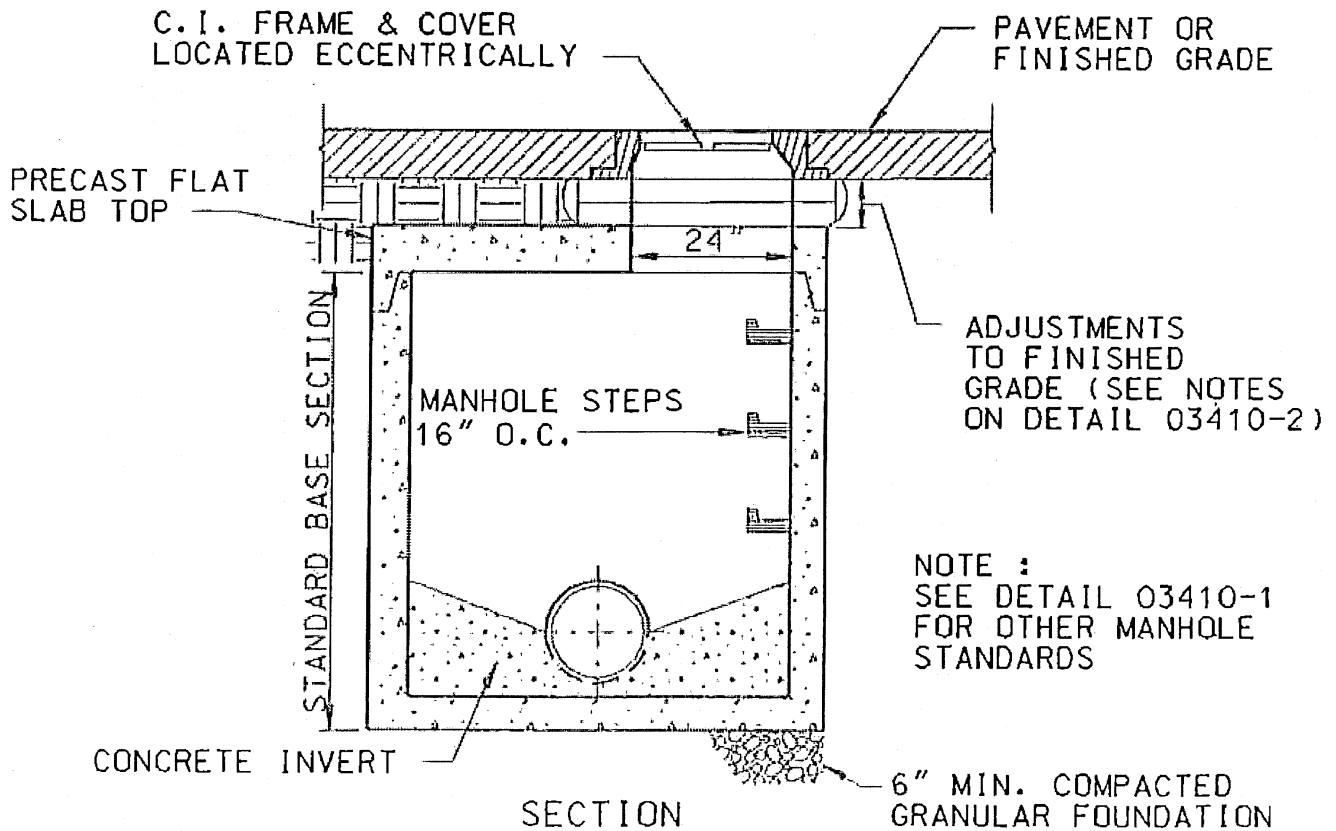

SECTION
(Typical for Flush Top)



City of Opportunity. Moving Forward!

DETAIL 3410-4 DOGHOUSE MANHOLE

SEE DETAIL 03410-1 FOR
CONCRETE INVERT AND TABLE
DESIGN

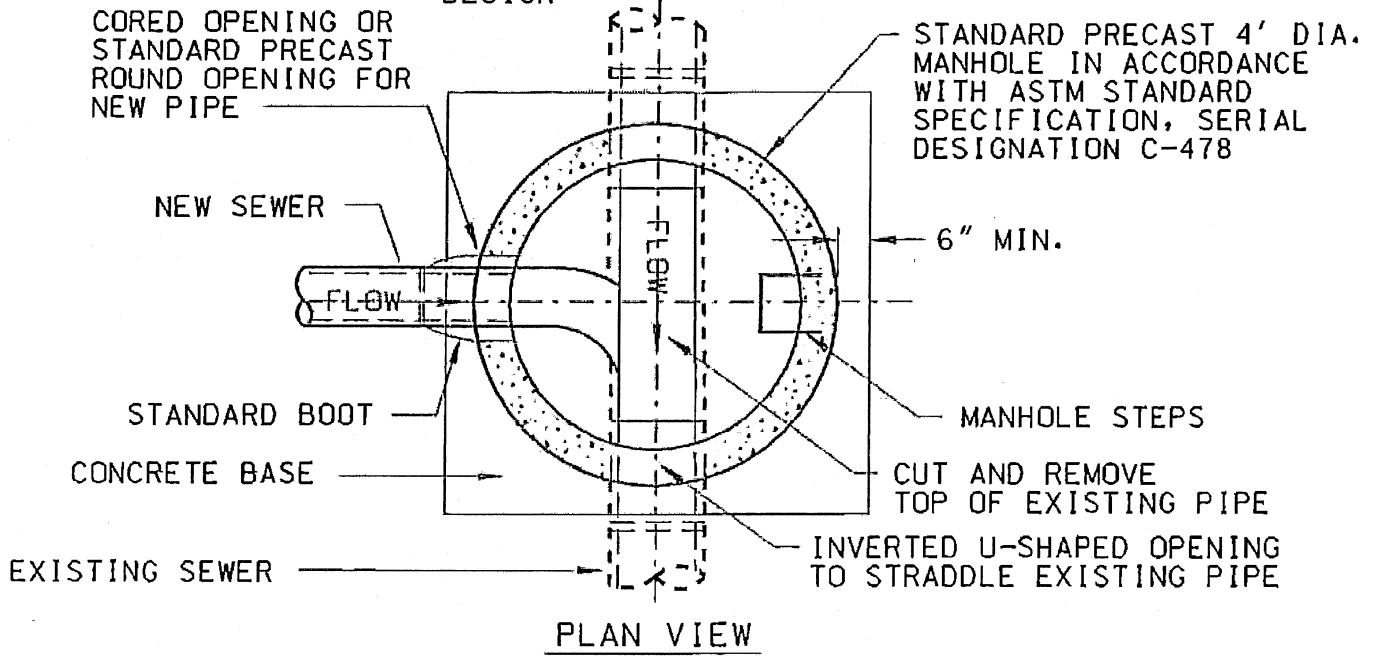

SEE DETAIL 03410-1
FOR OTHER
MANHOLE STANDARDS

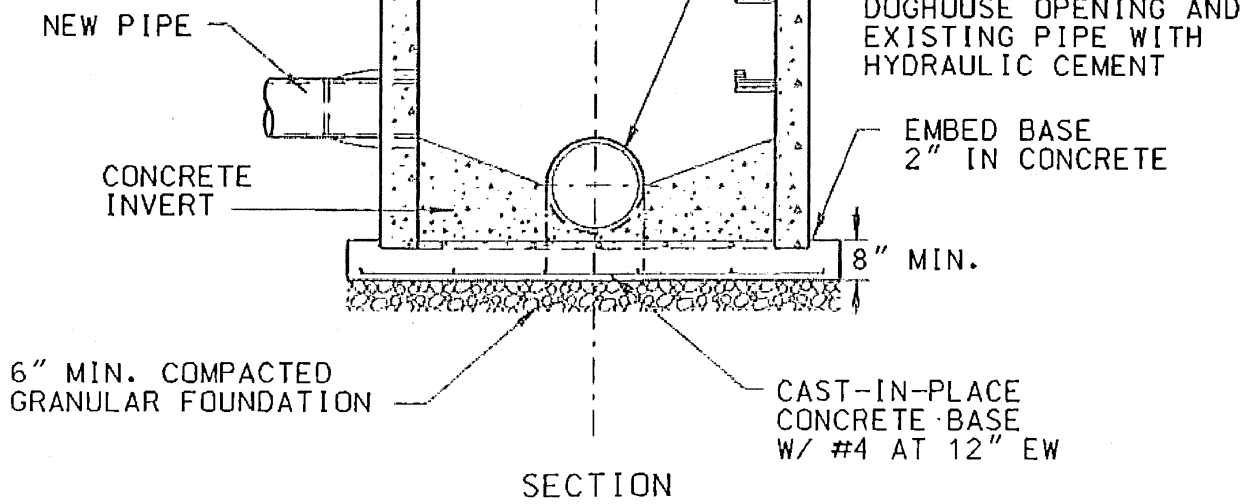



City of Opportunity. Moving Forward!

DETAIL 3410-5 DEEP MANHOLE (> 20 FEET MANHOLE)

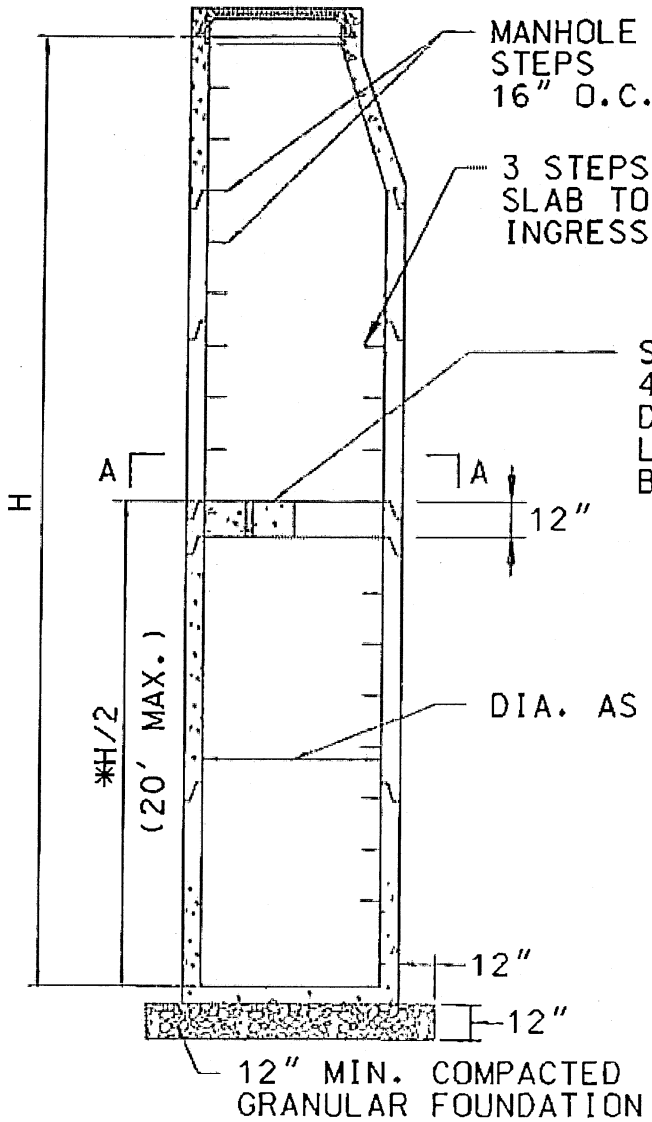

MANHOLE STEPS
16" O.C.

3 STEPS ABOVE
SLAB TO FACILITATE
INGRESS AND EGRESS

SAFETY PLATFORM
4,000 PSI CONCRETE SHALL BE
DESIGNED FOR A CONCENTRATED
LOAD OF 12,000 LBS WITH NON-SKID
BROOM FINISH.

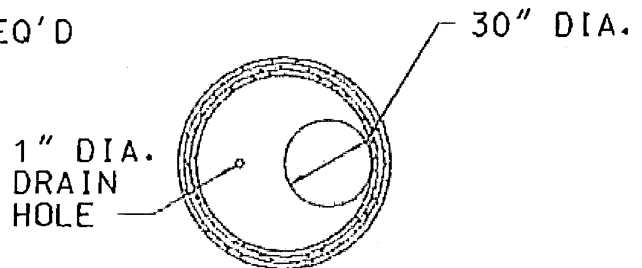

SECTION "A-A"
PLAN VIEW @ PLATFORM

* NOTE. IF H/2 EXCEEDS 20'
ADD ADDITIONAL SAFETY
PLATFORM(S)



City of Opportunity. Moving Forward!

DETAIL 3410-6 VENTED MANHOLE

PAINT PIPE W/
2 COATS BITUMINOUS
ENAMEL

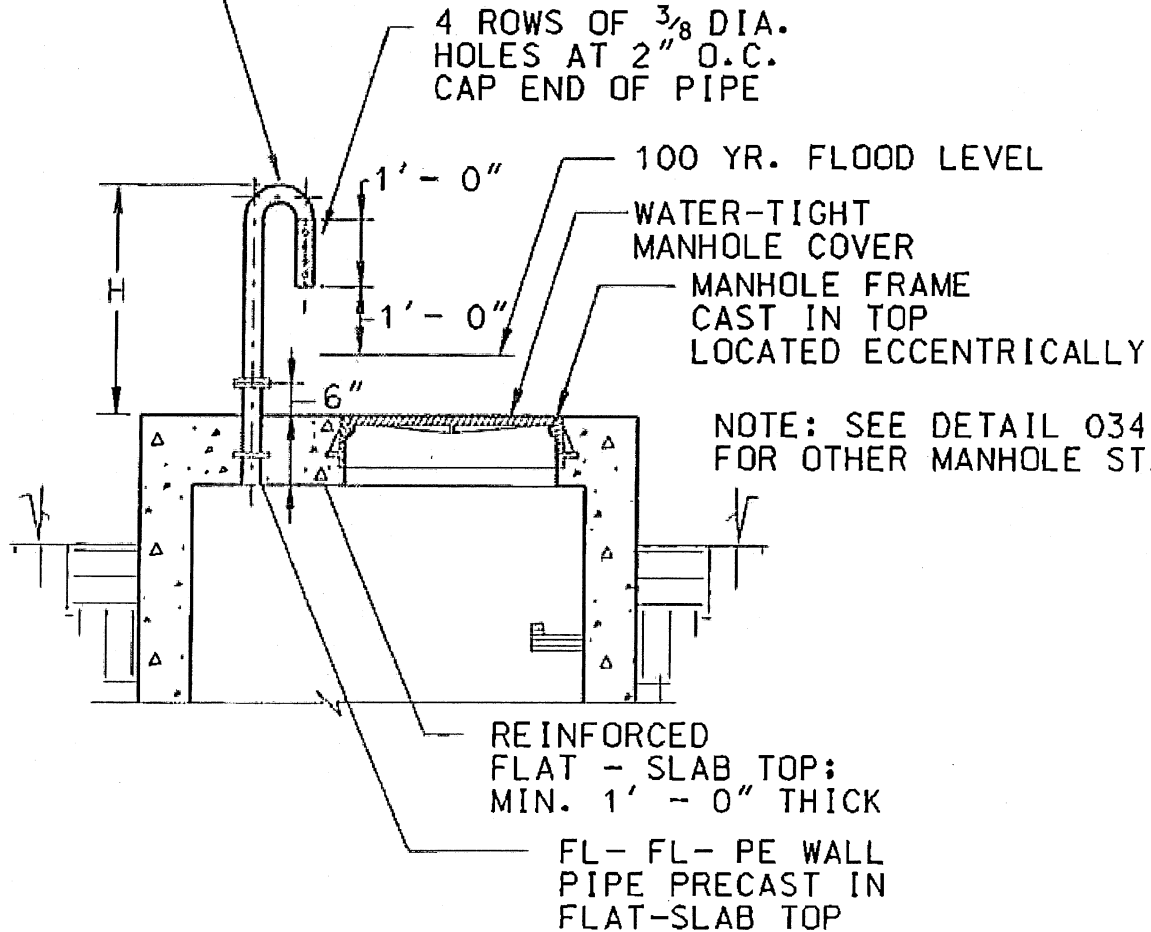

SECTION

STEEL PIPE SCHEDULE 80

- 3" DIA. FOR "H" LESS THAN 6' - 0"
- 4" DIA. FOR "H" = 6' - 0" TO 10' - 0"
- 5" DIA. FOR "H" = 10' - 0" TO 15' - 0"
- 6" DIA. FOR "H" = MORE THAN 15' - 0"



City of Opportunity. Moving Forward!

DETAIL 3410-7 OUTSIDE DROP MANHOLE CONNECTION

NOTE:
SEE DETAIL 03410-1 FOR
OTHER MANHOLE STANDARDS

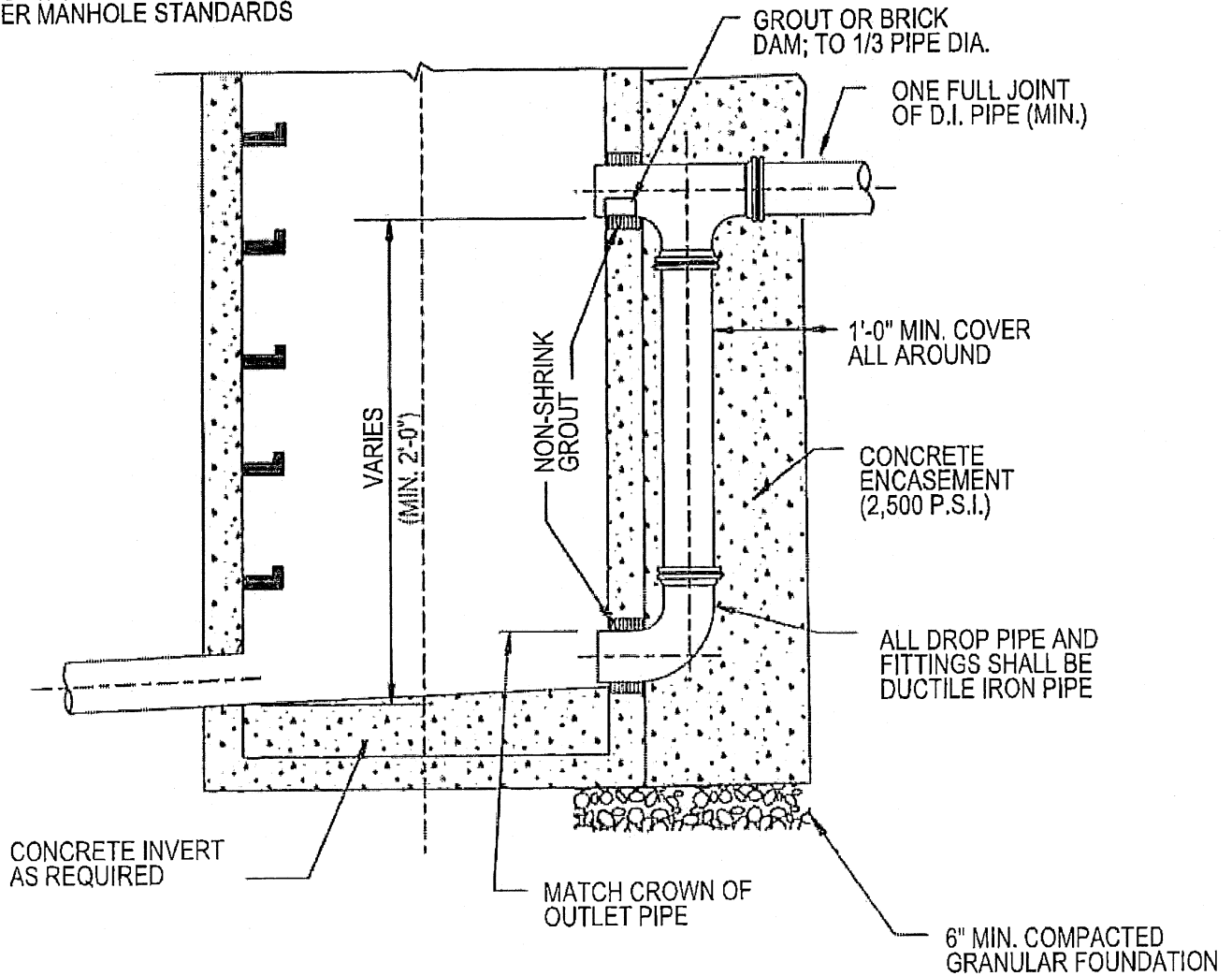



City of Opportunity. Moving Forward!

DETAIL 3410-8 INSIDE DROP MANHOLE CONNECTION

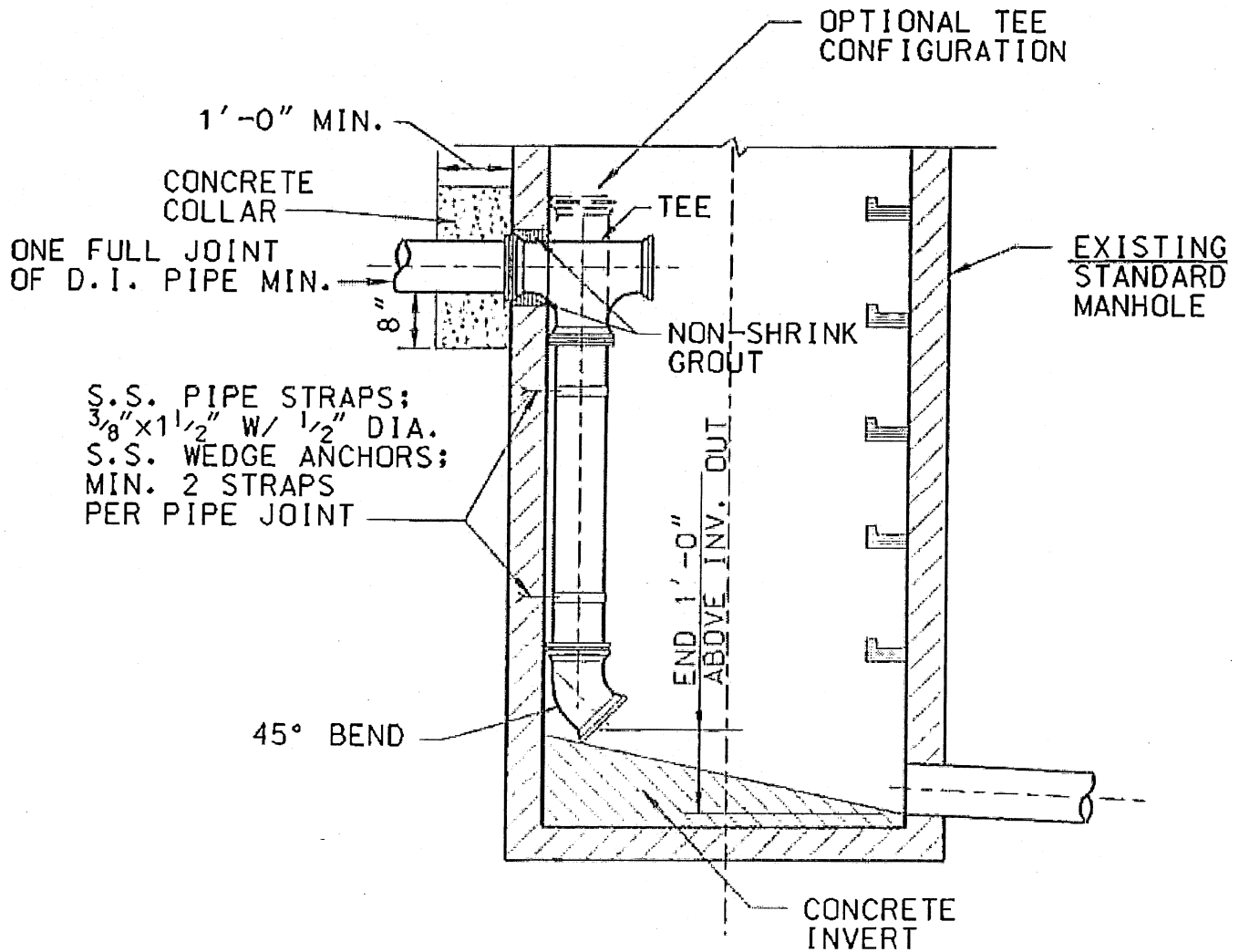

- NOTE: 1. INSIDE DROP CONNECTIONS SHALL ONLY BE USED WHERE APPROVED BY THE CITY OF AUSTELL.
2. ALL PIPING SHALL BE DUCTILE IRON. FITTINGS SHALL BE RESTRAINED JOINT.



City of Opportunity. Moving Forward!

DETAIL 3410-9 MANHOLE RAISING IN PAVEMENT

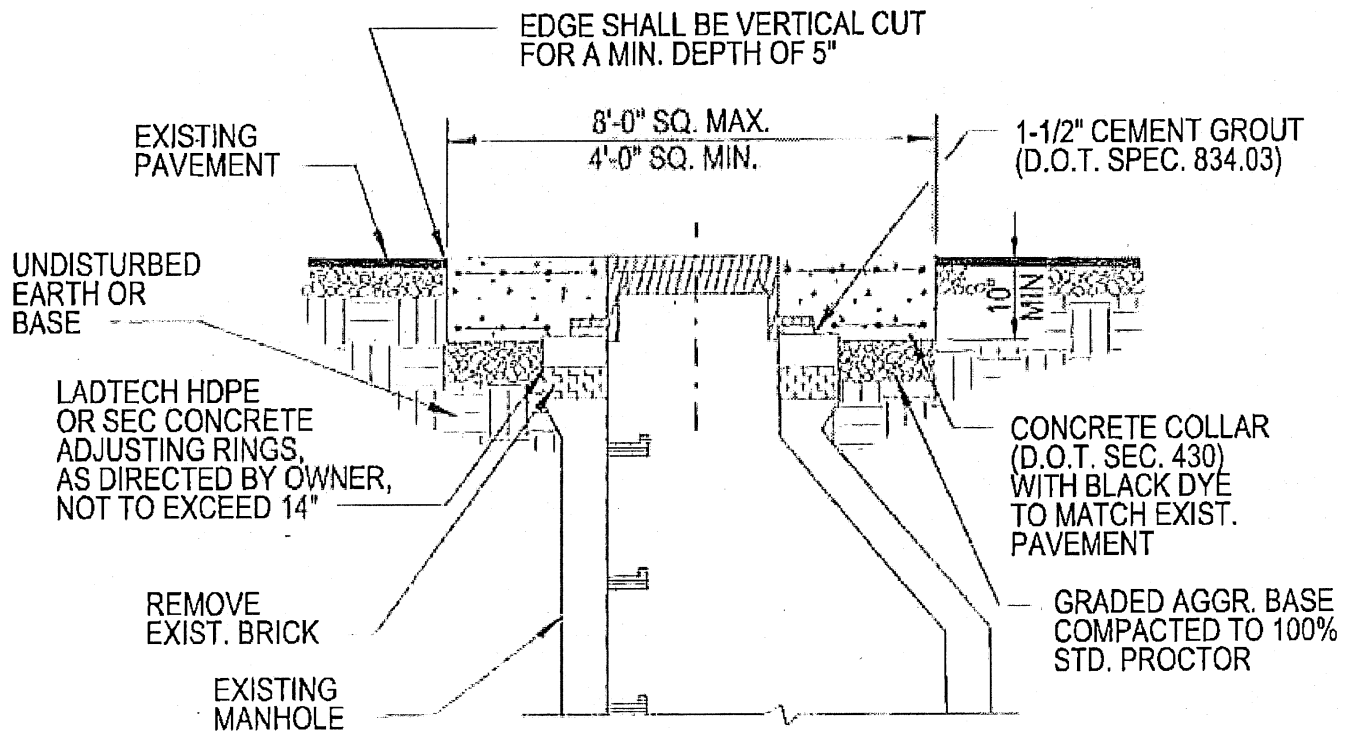

MANHOLE RAISING NOTES :

1. CONCRETE FOR COLLAR SHALL BE A MIN. OF 10" THICK.
2. IF REPLACEMENT OF THE FRAME & COVER IS NECESSARY, ACCEPTABLE PRODUCTS ARE EAST JORDAN IRON WORKS V-1480-1 OR U.S. FOUNDRY 360E.
3. ALL MANHOLE FRAME GRADE ADJUSTMENTS SHALL CONFORM TO THE REQUIREMENTS OF THIS DETAIL.
4. REINFORCEMENT SHALL BE CUT-TO-FIT MAT OF 6"x 6", 10x10 GAUGE WELDED WIRE FABRIC PLACED WITH 2" CLEARANCE FROM BOTTOM AND TOP SURFACES.



City of Opportunity. Moving Forward!

DETAIL 3410-10 MANHOLE RAISING OUT OF PAVEMENT

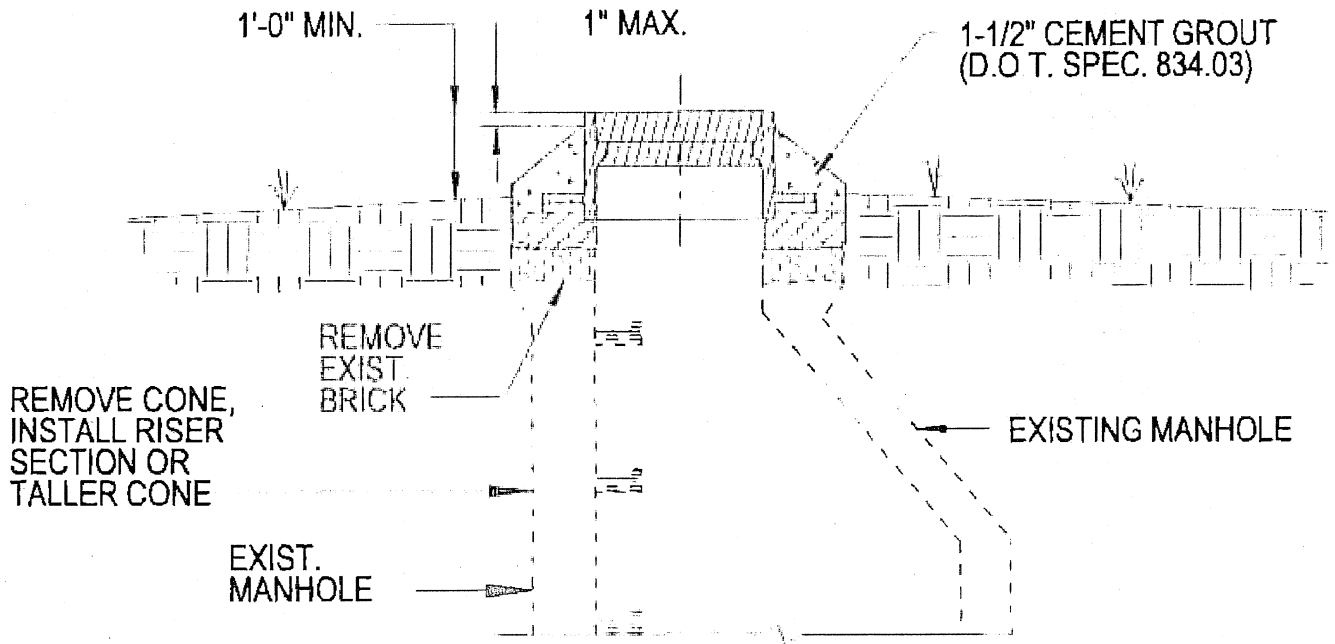

MANHOLE RAISING NOTES:

IF REPLACEMENT OF THE FRAME & COVER IS NECESSARY, ACCEPTABLE PRODUCTS ARE EAST JORDAN IRON WORKS V-1480-1, V-2480, V-2480-1, OR U.S. FOUNDRY 360E OR 360E/WT AS REQUIRED BY FIELD CONDITIONS OR DIRECTED BY OWNER.

RING AND COVER SHALL BE SECURED TO MANHOLE WITH FOUR EACH 1/2-INCH DIAMETER STAINLESS STEEL THREADED RODS (WITH NUTS AND WASHERS) EPOXY ADHESIVE ANCHORED INTO SOUND MANHOLE STRUCTURE (REFERENCE DETAIL 03410-30)



City of Opportunity. Moving Forward!

DETAIL 3410-11 STANDARD MANHOLE FRAME AND COVER

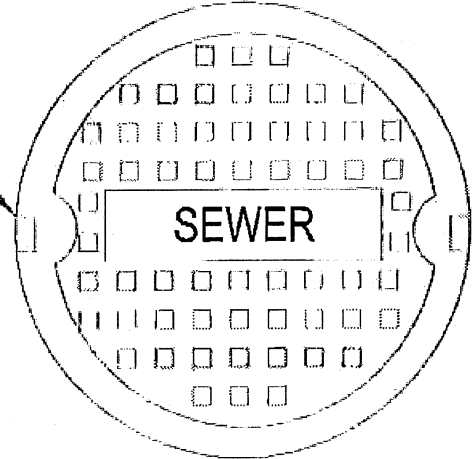
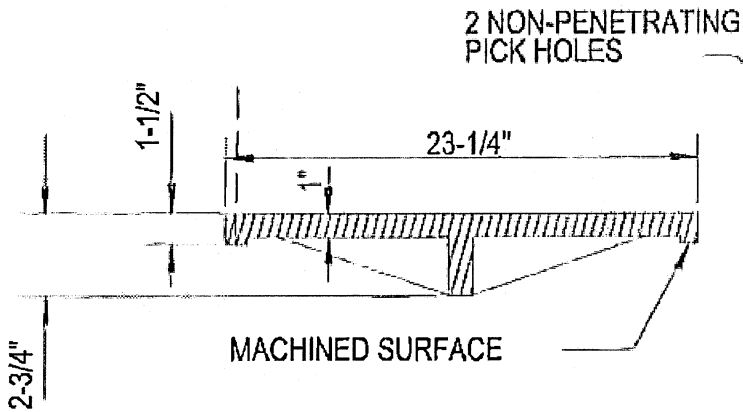

COVER
(MIN. WT. = 120 LBS.)

STANDARD FRAME AND COVER:

EAST JORDAN IRON WORKS V-1480,
U.S. FOUNDRY
MODEL USF-360E
OR APPROVED EQUAL.

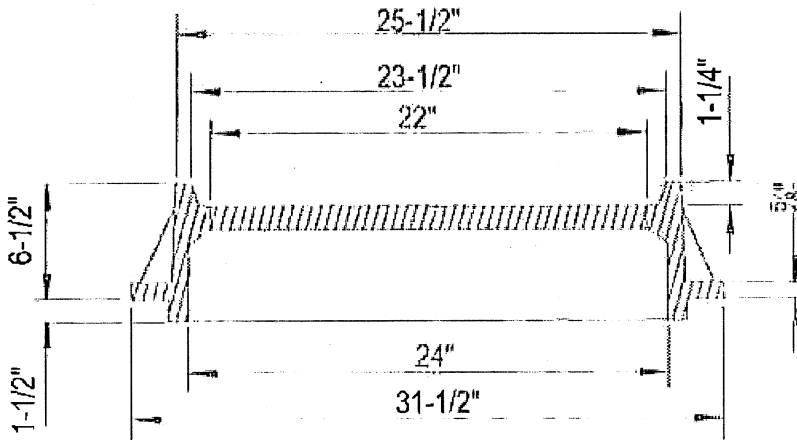

FRAME
(MIN. WT. = 170 LBS.)



City of Opportunity. Moving Forward!

DETAIL 3410-12 WATERTIGHT MANHOLE FRAME AND COVER

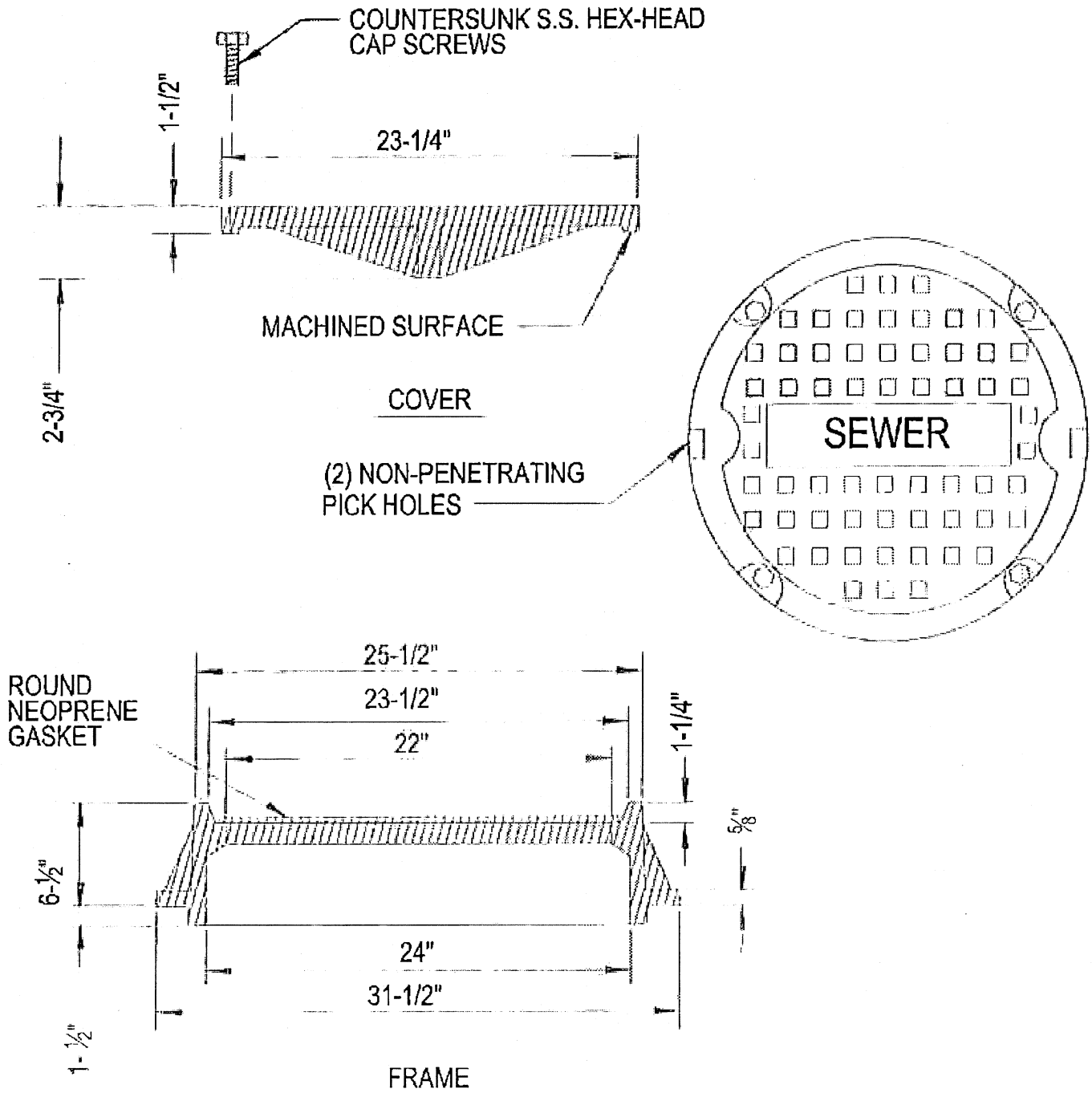



City of Opportunity. Moving Forward!

DETAIL 3410-13 STANDARD DETAIL FOR MANHOLE COVER STORMWATER MANAGEMENT

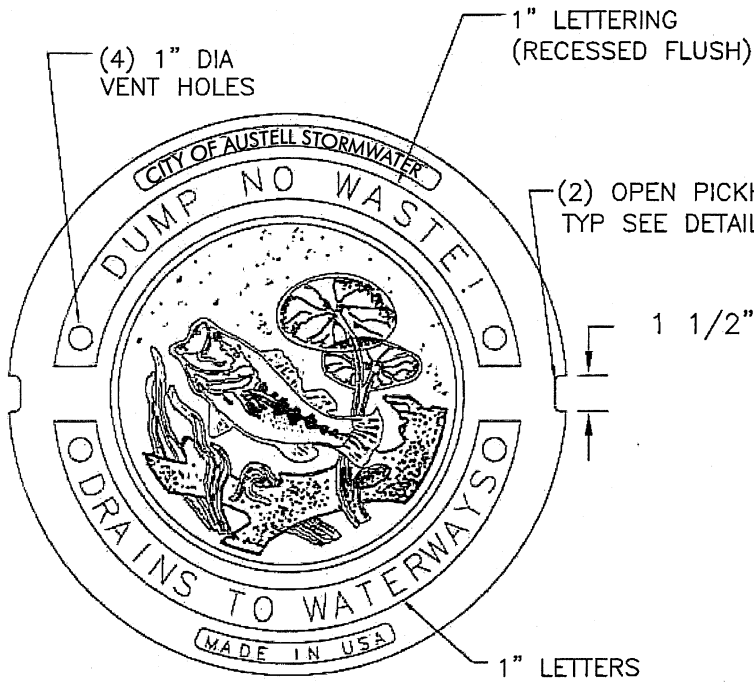

(2) OPEN PICKHOLES
TYP SEE DETAIL

1 1/2"

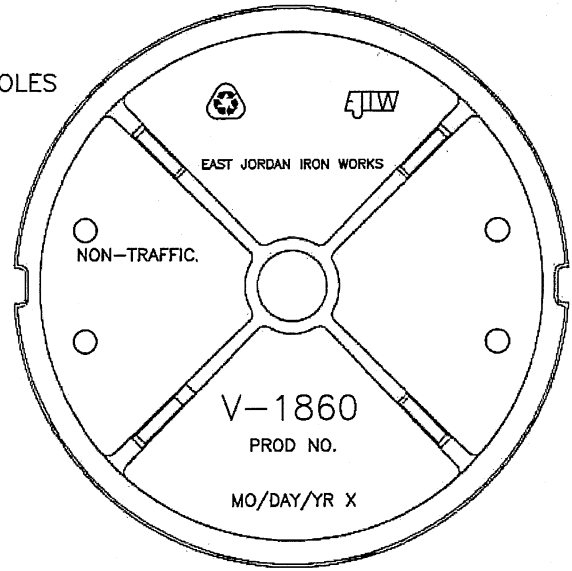

BOTTOM VIEW

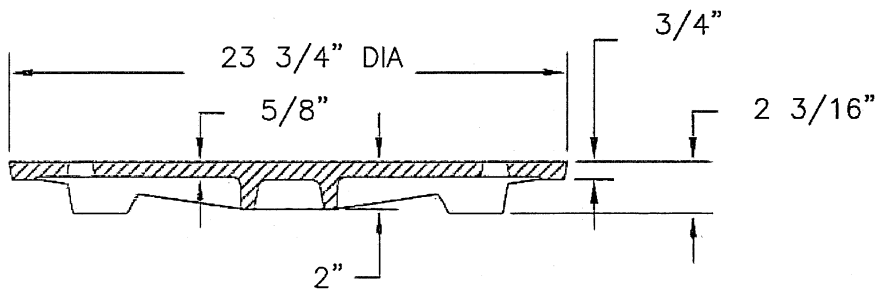

COVER SECTION

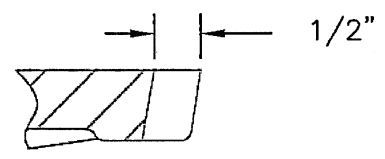

OPEN PICKHOLE DETAIL

OR EQUIVALENT



City of Opportunity. Moving Forward!

DETAIL 3410-20(A) GREASE TRAP

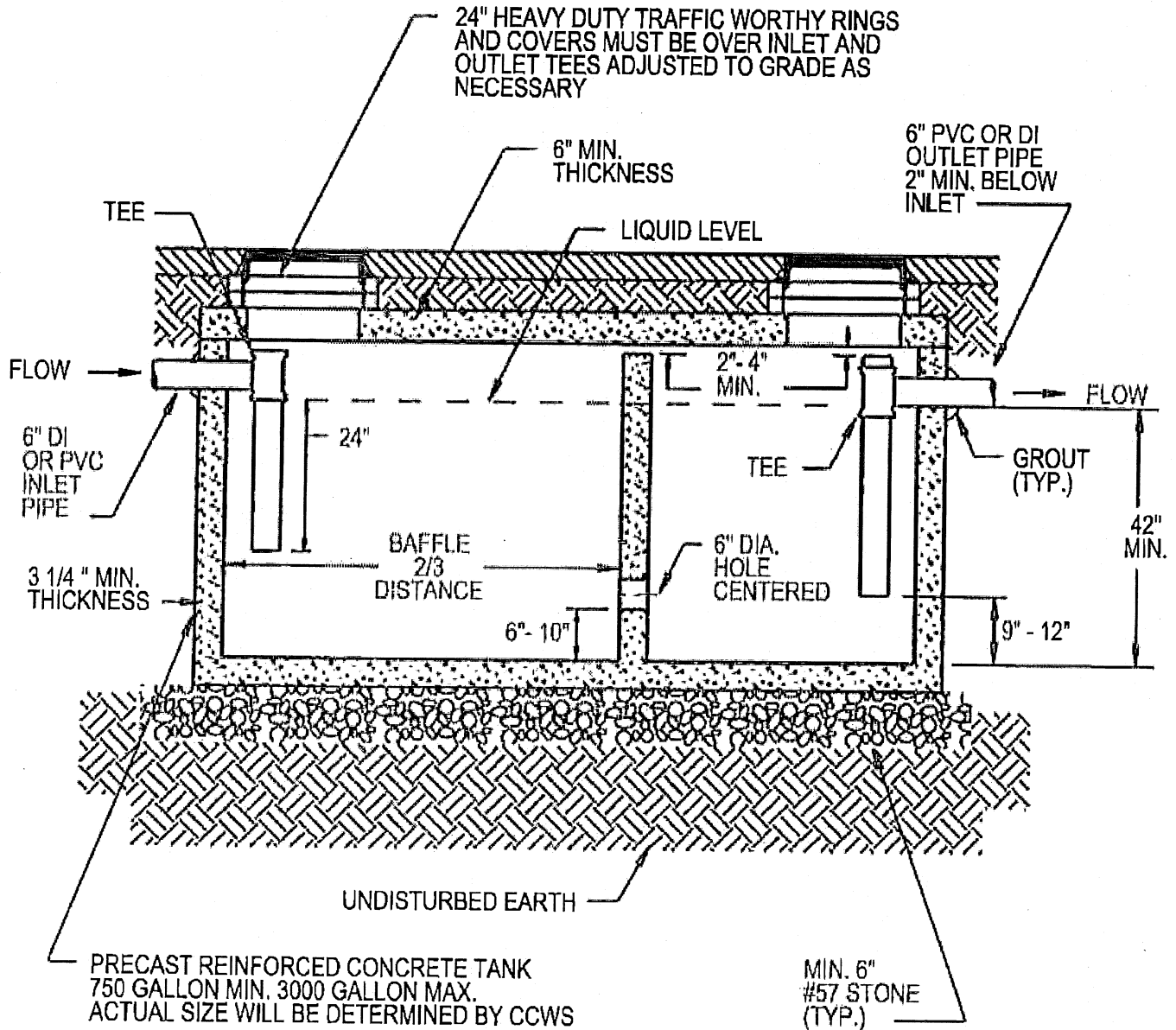



City of Opportunity. Moving Forward!

DETAIL 3410-20(B) NON-FOOD PREPARATION DUMPSTER TRAP

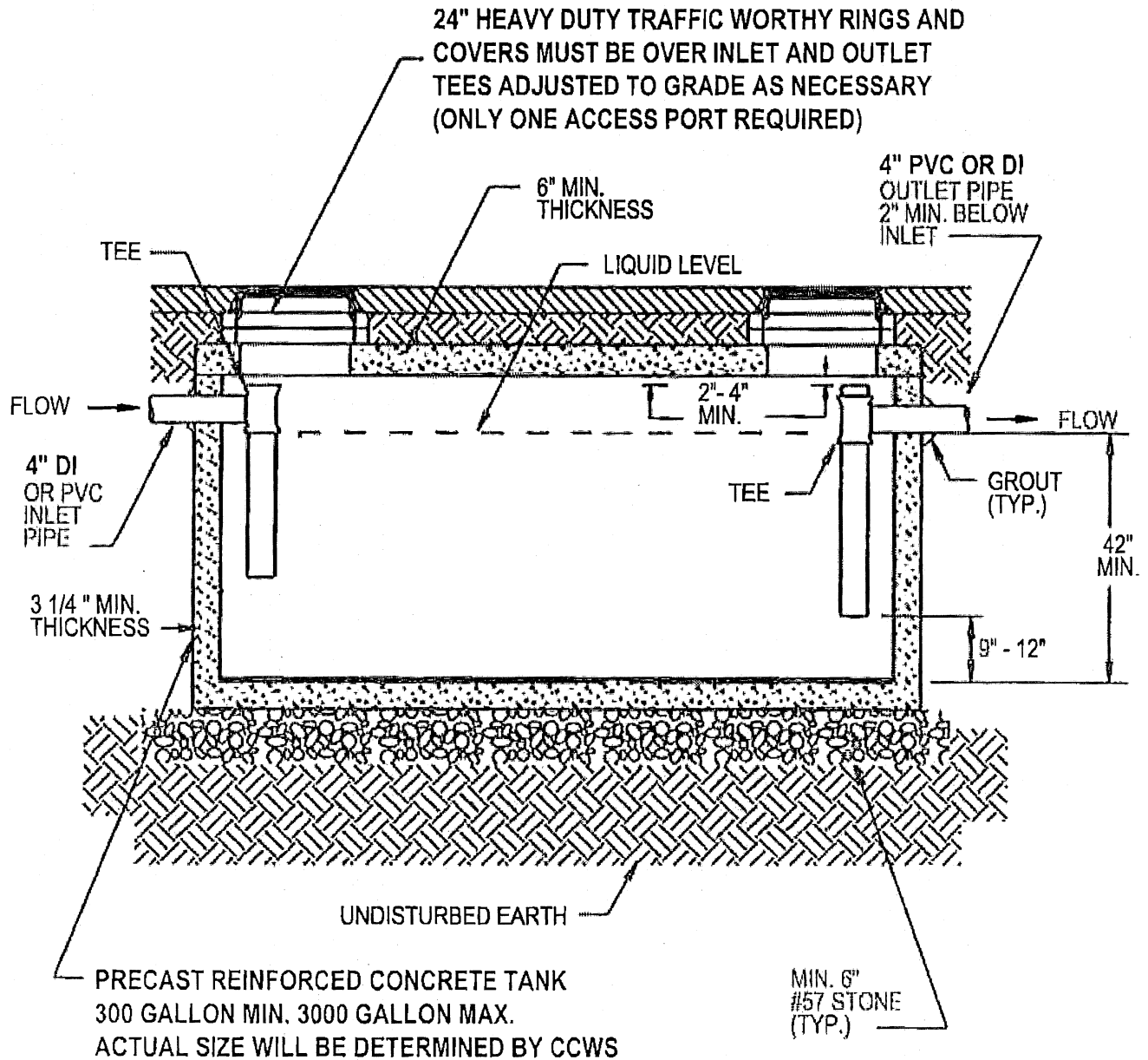

NOTE: INSPECTION BY COBB COUNTY WATER SYSTEM (ENVIRONMENTAL COMPLIANCE) IS REQUIRED BEFORE COVERING. CONTACT (770) 419-6340 TO SCHEDULE INSPECTION.



City of Opportunity. Moving Forward!

DETAIL 3410-30 MANHOLE FRAME AND COVER REPLACEMENT ON EXISTING MANHOLE OUT OF PAVEMENT

1/2" S.S. THREADED ROD
+ 7" LG.
W/S.S. WASHER & NUT,
4 EA.

EPOXY ADHESIVE
FILLED HOLE FOR
THREADED ROD
EMBEDMENT

3/4" D,
4" MIN. DEPTH
DRILLED HOLE,
4 EA.

FLEXIBLE PLASTIC GASKET
(RAM-NEK, KENT SEAL,
OR EQUAL)

EXISTING MH SECTION

WITHOUT MUD RING

WITH MUD RING

BOLT-DOWN WATER TIGHT
MH FRAME & COVER TO
REPLACE EXISTING. NEW
FRAME SHALL HAVE 3/4" D,
PREDRILLED HOLES FOR
ANCHORAGE.

SAND-CEMENT
GROUT

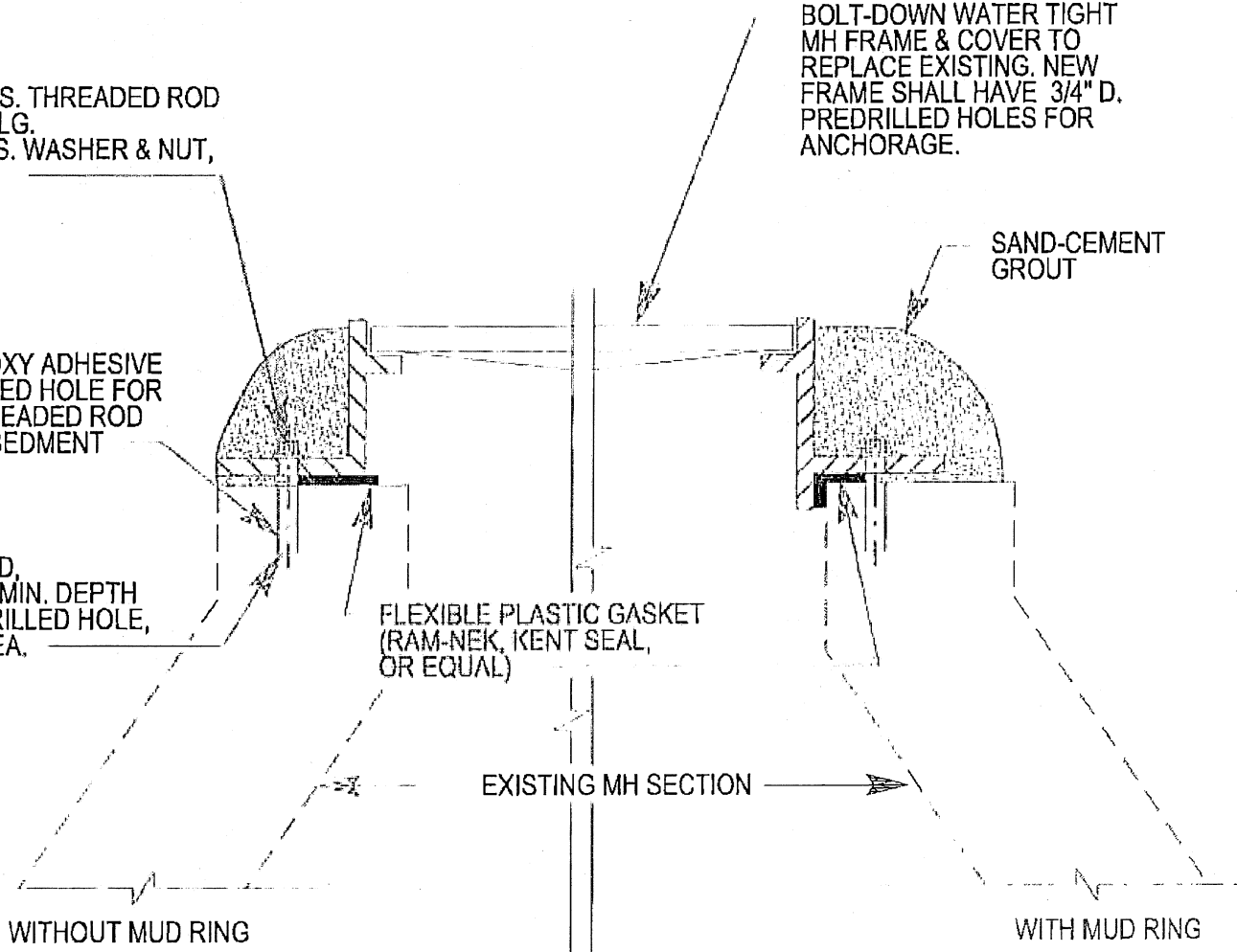



City of Opportunity. Moving Forward!

DETAIL 3410-31 MANHOLE RAISING FOR EXISTING MANHOLE ON EASEMENT

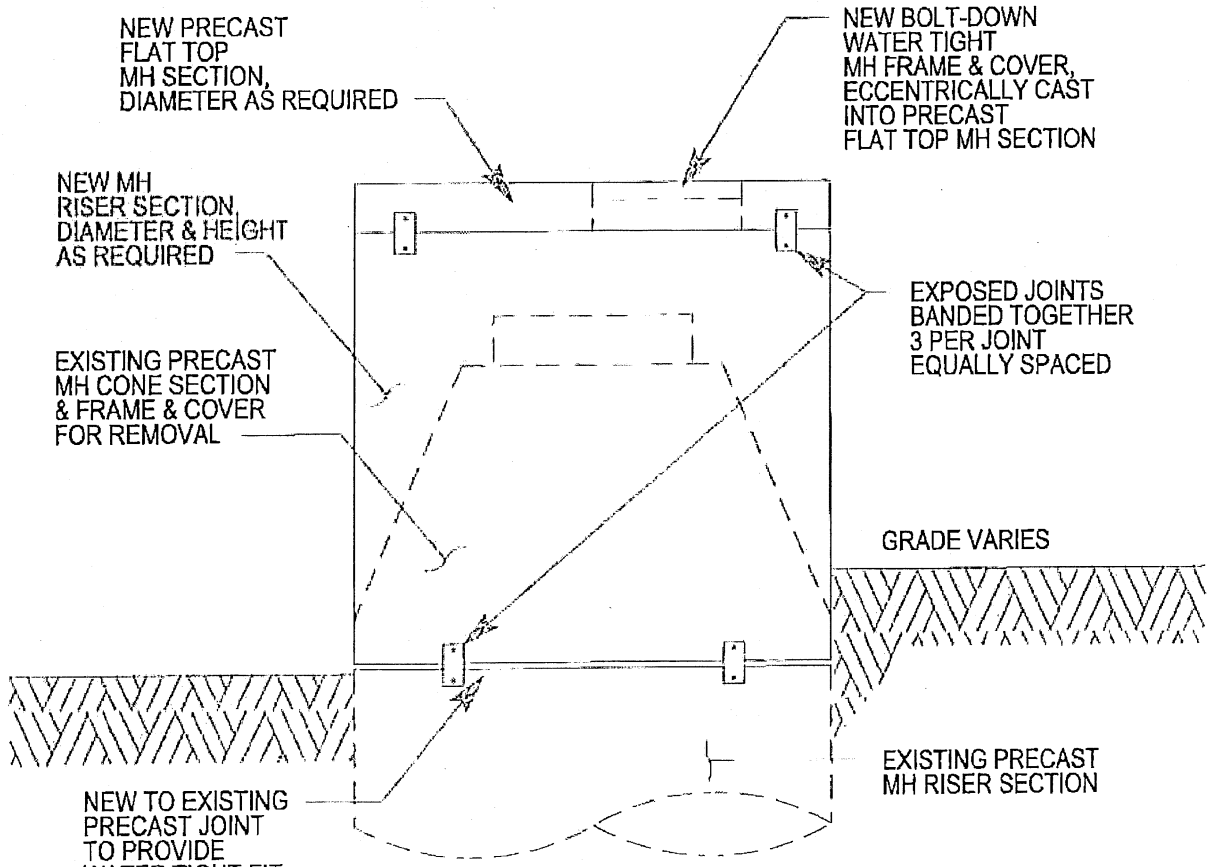

NEW PRECAST
FLAT TOP
MH SECTION,
DIAMETER AS REQUIRED

NEW BOLT-DOWN
WATER TIGHT
MH FRAME & COVER,
ECCENTRICALLY CAST
INTO PRECAST
FLAT TOP MH SECTION

NEW MH
RISER SECTION,
DIAMETER & HEIGHT
AS REQUIRED

EXPOSED JOINTS
BANDED TOGETHER
3 PER JOINT
EQUALLY SPACED

EXISTING PRECAST
MH CONE SECTION
& FRAME & COVER
FOR REMOVAL

GRADE VARIES

EXISTING PRECAST
MH RISER SECTION

NEW TO EXISTING
PRECAST JOINT
TO PROVIDE
WATER TIGHT FIT
(TONGUE & GROOVE
WITH "O"RING OR
FLEXIBLE PLASTIC
GASKET MATERIAL,
AND FURTHER SEALED
INSIDE AND OUTSIDE
WITH CEMENT MORTAR.)

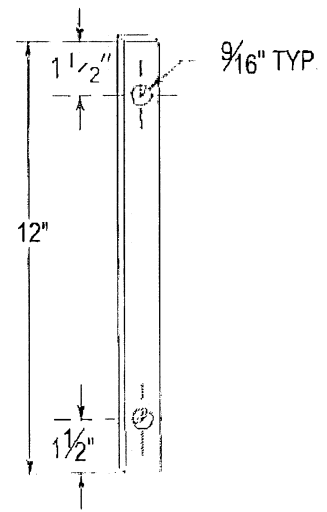
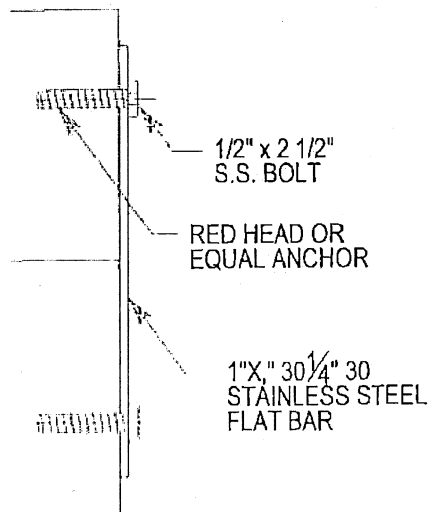

ANCHOR STRAP DETAIL



City of Opportunity. Moving Forward!

DETAIL 3410-32 RAISING BRICK MANHOLE WITH PRECAST SECTION

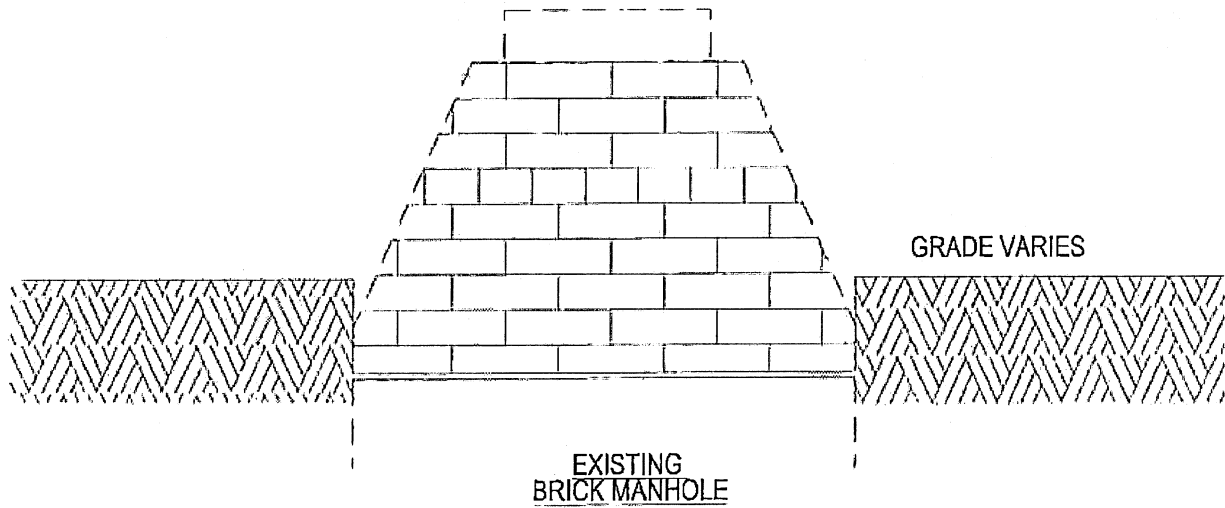

NEW TO EXISTING

